

# **SD17063 Rev. B Stepper Drive**

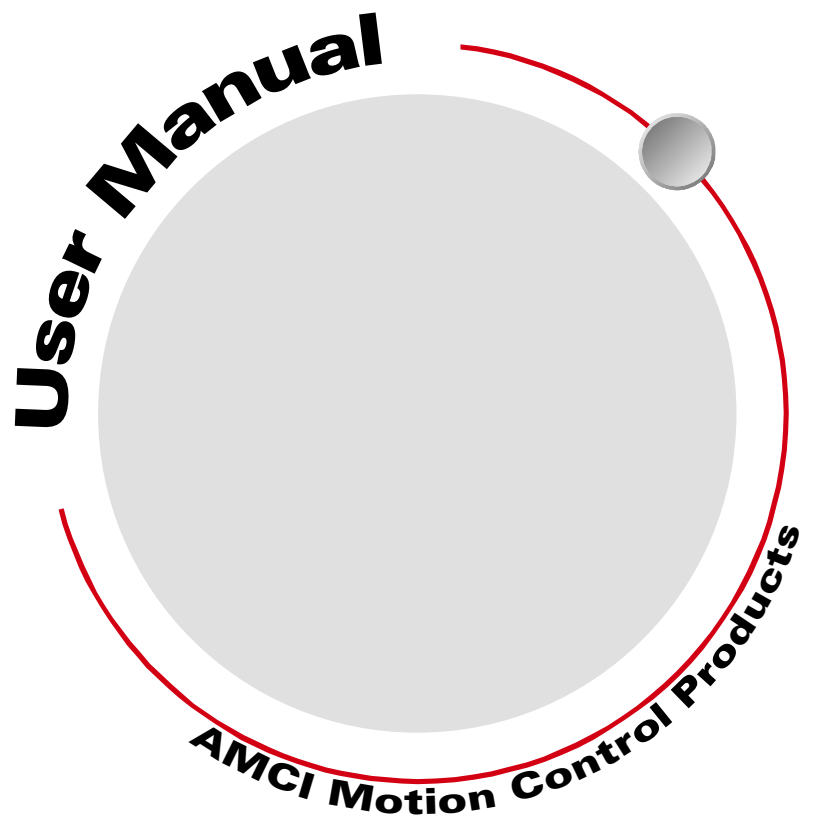

**Built With  
DuraDrive™  
Technology**

# GENERAL INFORMATION

## **Important User Information**

The products and application data described in this manual are useful in a wide variety of different applications. Therefore, the user and others responsible for applying these products described herein are responsible for determining the acceptability for each application. While efforts have been made to provide accurate information within this manual, AMCI assumes no responsibility for the application or the completeness of the information contained herein.

UNDER NO CIRCUMSTANCES WILL ADVANCED MICRO CONTROLS, INC. BE RESPONSIBLE OR LIABLE FOR ANY DAMAGES OR LOSSES, INCLUDING INDIRECT OR CONSEQUENTIAL DAMAGES OR LOSSES, ARISING FROM THE USE OF ANY INFORMATION CONTAINED WITHIN THIS MANUAL, OR THE USE OF ANY PRODUCTS OR SERVICES REFERENCED HEREIN.

No patent liability is assumed by AMCI, with respect to use of information, circuits, equipment, or software described in this manual.

The information contained within this manual is subject to change without notice.

This manual is copyright 2001 by Advanced Micro Controls Inc. You may reproduce this manual, in whole or in part, for your personal use, provided that this copyright notice is included. You may distribute copies of this complete manual in electronic format provided that they are unaltered from the version posted by Advanced Micro Controls Inc. on our official website: [www.amci.com](http://www.amci.com). You may incorporate portions of this documents in other literature for your own personal use provided that you include the notice "Portions of this document copyright 2001 by Advanced Micro Controls Inc." You may not alter the contents of this document or charge a fee for reproducing or distributing it.

## **Standard Warranty**

ADVANCED MICRO CONTROLS, INC. warrants that all equipment manufactured by it will be free from defects, under normal use, in materials and workmanship for a period of [1] year. Within this warranty period, AMCI shall, at its option, repair or replace, free of charge, any equipment covered by this warranty which is returned, shipping charges prepaid, within one year from date of invoice, and which upon examination proves to be defective in material or workmanship and not caused by accident, misuse, neglect, alteration, improper installation or improper testing.

The provisions of the "STANDARD WARRANTY" are the sole obligations of AMCI and excludes all other warranties expressed or implied. In no event shall AMCI be liable for incidental or consequential damages or for delay in performance of this warranty.

## **Returns Policy**

All equipment being returned to AMCI for repair or replacement, regardless of warranty status, must have a Return Merchandise Authorization number issued by AMCI. Call (860) 585-1254 with the model number and serial number (if applicable) along with a description of the problem. A "RMA" number will be issued. Equipment must be shipped to AMCI with transportation charges prepaid. Title and risk of loss or damage remains with the customer until shipment is received by AMCI.

## **24 Hour Technical Support Number**

24 Hour technical support is available on this product. For technical support, call (860) 583-7271. Your call will be answered by the factory during regular business hours, Monday through Friday, 8AM - 5PM EST. During non-business hours an automated system will ask you to enter the telephone number you can be reached at. Please remember to include your area code. The system will page one of two engineers on call. Please have your product model number and a description of the problem ready before you call.

## **We Want Your Feedback**

Manuals at AMCI are constantly evolving entities. Your questions and comments on this manual are both welcomed and necessary if this manual is to be improved. Please direct all comments to: Technical Documentation, AMCI, 20 Gear Drive, Terryville CT 06786, or fax us at (860) 584-1973. You can also e-mail your questions and comments to [techsupport@amci.com](mailto:techsupport@amci.com)

# ABOUT THIS MANUAL

Read this chapter to learn how to navigate through the manual and familiarize yourself with the conventions used in it. The last section of this chapter highlights the manual's remaining chapters and their targeted audiences.

## Audience

This manual explains the set-up, installation, and operation of AMCI's SD17063 Rev. B stepper motor drive with DuraDrive Technology™.

It is written for the engineer responsible for incorporating the SD17063 into a design, as well as the engineer or technician responsible for its actual installation.

## Navigating this Manual

This manual is designed to be used in both printed and on-line formats. Its on-line form is a PDF document, which requires Adobe Acrobat Reader version 4.0+ to open it.

Bookmarks of all the chapter names, section headings, and sub-headings were created in the PDF file to help navigate it. The bookmarks should have appeared when you opened the file. If they didn't, press the F5 key on Windows platforms to bring them up.

Throughout this manual you will also find *green text that functions as a hyperlink* in HTML documents. Clicking on the text will immediately jump you to the referenced section of the manual. If you are reading a printed manual, most links include page numbers.

The PDF file is password protected to prevent changes to the document. You are allowed to select and copy sections for use in other documents and, if you own Adobe Acrobat version 4.05 or later, you are allowed to add notes and annotations.

## Manual Conventions

Three icons are used to highlight important information in the manual:



**NOTES** highlight important concepts, decisions you must make, or the implications of those decisions.



**CAUTIONS** tell you when equipment may be damaged if the procedure is not followed properly.



**WARNINGS** tell you when people may be hurt or equipment may be damaged if the procedure is not followed properly.

The following table shows the text formatting conventions:

Format	Description
Normal Font	Font used throughout this manual.
<i>Emphasis Font</i>	Font used the first time a new term is introduced.
<i>Cross Reference</i>	When viewing the PDF version of the manual, clicking on the cross reference text jumps you to referenced section.

## Trademark Notices

“DuraDrive”, “DuraDrive Technology”, and the AMCI logo are trademarks, and “AMCI” is a registered trademark of Advanced Micro Controls Inc. “SLC” and “SLC 500” are registered trademarks and “MicroLogix” is a trademark of Allen-Bradley Company. “Adobe” and “Acrobat” are registered trademarks of Adobe Systems Incorporated.

All other trademarks contained herein are the property of their respective holders.

## Revision Record

This manual, 940-0S013, is the fourth revision of this manual. This revision clarifies some drawings, adds information on disabling Anti-resonance when using the drive's self test, and adds information on converting from an SD8055 to the SD17063 Rev. B. It was first released March 8<sup>th</sup>, 2002.

## Revision History

940-0S012: 04/05/2001. Update for Rev. B drive.

940-0S011: 05/21/2000. Update for Rev. A drive

940-0S010: 06/02/1998. Initial Release.

## Where To Go From Here

This manual contains information that is of interest to everyone from engineers to operators. The table below gives a brief description of each chapter's contents to help you find the information you need to do your job.

CHP Num.	Chapter Title	Intended Audience
1	<b>INTRODUCTION TO THE SD17063</b>	Anyone new to the SD17063. This chapter gives a basic overview of the features available on the unit, typical applications, and complementary equipment.
2	<b>SPECIFICATIONS</b>	Anyone that needs detailed information on the drive itself.
3	<b>SD17063 SWITCH SETTINGS</b>	Anyone that must determine switch settings when installing the SD17063.
4	<b>GENERAL INSTALLATION GUIDELINES</b>	Anyone new to installing electronic controls in an industrial environment. The chapter includes general information on grounding, wiring, and surge suppression that is applicable to any controls installation.
5	<b>INSTALLING THE SD17063 REV. B.</b>	Anyone that must install a SD17063 on a machine. Includes information on mounting, grounding, and wiring specific to the unit. The chapter also gives guidelines for testing the system once it's installed.
APX A	<b>CHOOSING YOUR MOTOR</b>	Anyone that must choose a motor for an application.
APX B	<b>UPGRADING TO THE SD17063 REV. B</b>	Anyone that is upgrading to the SD17063 Rev. B from AMCI's SD8055 or older SD17063's.
APX C	<b>TROUBLESHOOTING</b>	Anyone that needs a concise reference of potential problem symptoms and their solutions.

Table 0.1 Chapter Index

As a first step, consider photocopying the **SD17063 Worksheet** found on page 17. The worksheet gives space to write down all of your setup decisions in one place.

## INTRODUCTION TO THE SD17063

The Rev. B drive makes a few minor improvements to the Rev. A drive and it retains the new features and switch setting that were not available on the older, non-revised SD17063 drives. Therefore, this manual can be used with the SD17063 Rev. A drives with the exceptions noted below. This manual cannot be used with the older, non-revised SD17063 drives. The easiest way to determine if you have a revised or non-revised drive is by the power connector. The new SD17063 Rev. A and B drives have a green, three terminal, Phoenix Contact connector while the older SD17063 drive has an IEC power connector.

### Stepper Motor Systems

When you must control rotational position or velocity, stepper motors have several advantages over servo control systems. The first is cost. Opposed to 'closed loop' servo systems that require position feedback to the drive, stepper systems operate 'open loop', accurately controlling position and velocity without feedback. Eliminating the feedback loop can result in a great cost savings. The stepper motor itself is also tough, easy to install, and offers high output torque for its size.

As shown in figure 1.1, there are three basic components to a stepper system.

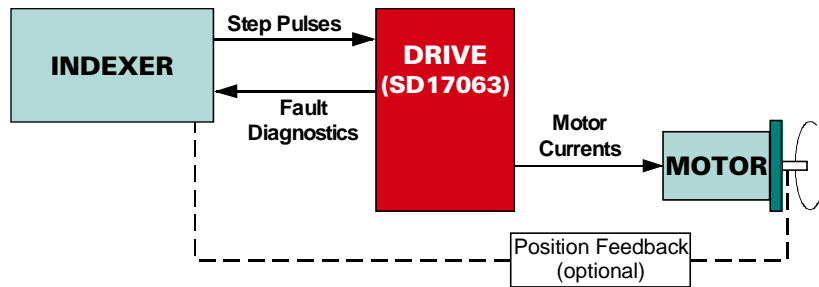

Figure 1.1 Block Diagram of a Stepper System

- ▶ **The Indexer** – The indexer, sometimes called the controller, generates directional pulses that control the position, velocity, and rotational direction of the stepper motor. Indexers can take on many forms, from a fully programmable card for a programmable logic controller or PC, to a 'black box' that runs a fixed profile whenever an operator presses a button.
- ▶ **The Drive** – The drive converts the directional pulses from the indexer into the current waveforms needed to drive the stepper motor. The SD17063 accepts differential signals from the indexer and outputs 170Vdc digitized waveforms to the motor with a maximum current of 6.3Arms. The SD17063 also has fault diagnostics that warn you of problems with the motor connections or directional pulses from the indexer. The SD17063's fault output is typically fed back to the indexer.
- ▶ **The Motor** – Stepper motors are available in many different sizes to meet specific torque requirements. AMCI offers motors that range in size from NEMA 23 to NEMA 42.

A position feedback device, such as an optical encoder or resolver, can be added to the system if desired. The feedback is between the motor and the indexer, and therefore its specification and installation is not covered in this manual.



**The SD17063 Rev. B With DuraDrive Technology**

AMCI’s SD17063 is an advanced, high-power microstepping drive for NEMA 17 through NEMA 42 frame size motors. The drives many features include:

- DuraDrive Technology protects the drive from extremes in temperature, input voltage, and motor regeneration currents.
- Self Test
- Programmable RMS or Peak motor current control
- Detection of nine different faults
- Reset and Disable inputs
- Programmable Idle Current Reduction
- Programmable Current Loop Gain
- Programmable Motor Anti-resonance feature
- Programmable Output Waveform in microstepping applications

Connections to the indexer are made through opto-isolated differential inputs. Differential inputs have greater noise immunity than single ended inputs. This means you can run longer cables, (up to 300 feet), from the indexer to the SD17063, and place the drive closer to the motor. A shorter motor cable means less power loss from cable resistance, which means more torque from the motor.

**What’s Included in the Drive Package**

The following table lists the items included with the SD17063 Rev. B drive when shipped from AMCI. If you don’t have all of these parts, contact your distributor or AMCI for help.

Description	AMCI Part Number
Stepper Drive	SD17063 Rev. B
Indexer Connector	MS-10WP
Motor Connector w/ Rubber Boot	MC-1
Power Connector w/ Rubber Boot	PC-1
Screwdriver	890-90303

Table 1.1 SD17063 Ship List

## Other AMCI Stepper Products

The following table lists some of our other stepper products, but the line is constantly growing so the list may be incomplete. For the latest information on all of our products, browse through our website [www.amci.com](http://www.amci.com).

Model Number	Product Type	Description
SD17040	Drive	Full Step / Half Step drive with an 170 Vdc motor bus and output current up to 4.0Apk. The drive also has settings for Idle Current Reduction. Differential I/O supports cable lengths of up to 300 feet from indexer to drive.
SD17098IC	Indexer/Drive Combination	Programmed over ControlNet or an RS-232/485 port, the unit is a microstepping drive with an 170 Vdc motor bus and output current up to 9.8Arms. With other drive specifications similar to the SD17063 Rev. B, this unit also has an integral indexer that accepts commands from the ControlNet or serial ports. Designed to save the cost of a separate indexer module for applications that are already using ControlNet or a multi-drop serial link, the indexer supports blended move profiles as well as velocity mode programming.
3202	ControlLogix Module	Two channel stepper indexer module for the ControlLogix backplane with incremental encoder position feedback. Featuring blended move profiles and profiles based on encoder feedback, the module also has multiple inputs for homing and over travel protection.
3204	ControlLogix Module	Four channel stepper indexer module for the ControlLogix backplane. Featuring blended move profiles, the module also has multiple inputs for homing and over travel protection.
SM23-“x”	Size 23 Motors	Size 23 stepper motors that are available in 1, 2, or 3 stack configurations. Other options include double shafts and/or integrated optical encoders for position feedback. Go to Appendix A, <b>CHOOSING YOUR MOTOR</b> , starting on page 45 or <a href="http://www.amci.com">www.amci.com</a> for a complete listing of available motors.
SM34-“x”	Size 34 Motors	Size 34 stepper motors that are available in 1, 2, or 3 stack configurations. Other options include double shafts and/or integrated optical encoders for position feedback. Go to Appendix A, <b>CHOOSING YOUR MOTOR</b> , starting on page 45 or <a href="http://www.amci.com">www.amci.com</a> for a complete listing of available motors.
SM42-“x”	Size 42 Motors	Size 42 stepper motors that are available with double shafts and/or integrated optical encoders for position feedback. Go to Appendix A, <b>CHOOSING YOUR MOTOR</b> , starting on page 45 or <a href="http://www.amci.com">www.amci.com</a> for a complete listing of available motors.

Table 1.2 AMCI Stepper Products



### ***Other Products From AMCI***

AMCI has been serving the industrial automation sector since 1985, and we have a broad range of other products that are used in industrial applications.

- **DURACODERS:** Absolute, Analog, or Incremental encoders that replace the fragile glass disk and sensitive optics of optical encoders with an industrial resolver. The size 25 DuraCoders are drop in replacements for similar sized optical encoders. In motion applications, a DuraCoder is typically used for position feedback.
- **PLC PLUG-IN MODULES:** AMCI offers a broad range of PLC plug-in modules for most major PLC brands including A-B ControlLogix, SLC500 and 1771 I/O, GE Fanuc 90-70 and 90-30, and Modicon Quantum. Modules include resolver, LDT, and SSI interfaces, programmable limit switches, indexers and registration control modules.
- **RESOLVER TRANSDUCERS:** AMCI is the only company in the market place to manufacturer its own resolvers. Not only do we make the resolvers for our own products, we also produce resolvers with different electrical specifications for other position feedback applications such as servo control.

For additional information on these items and the rest of our product lines, browse through our website [www.amci.com](http://www.amci.com), or contact AMCI or your local AMCI distributor.



# CHAPTER 2

## SPECIFICATIONS

### Drive Type

Two bipolar MOSFET H-bridges with 170V output bus. 20KHz PWM current control. Internal 25 watt regeneration resistor.

### Weight

4.3 lbs. (2.0 kg.)

### Inputs

Electrical Characteristics for all Inputs: .....  
Differential. 1500 Vac/dc opto-isolated. Can be wired as single ended inputs.

Step ..... Motor steps on high going pulse. 200nS min. pulse width, 2 MHz maximum input frequency.

Disable . Active high. Disables current to motor. Drive does not accept steps while disabled.

Reset .... Active high. Resets the drive after a fault condition. Also forces drive to update latched switch settings.

### Fault Output

Electrical Characteristics: .....  
Open Collector/Emitter. 1500 Vac/dc opto-isolated. 30Vdc, 20 mA max.

The Fault Output is normally on. Turns off under the following conditions:

Disable/Reset The Disable or Reset input is active, or drive initialization is not complete.

Short Circuit . Motor Phase to Phase or Phase to Ground

Over Temp .... Heat Sink temperature exceeds 95° C (200° F)

No Motor ..... The motor interlock terminals are not connected.

Over Voltage . The voltage on the output bus exceeded 250 Volts

### Pulse Train Input

Switch selectable to CW/CCW or Pulse/Direction.

### Anti-Resonance Circuit

Circuit that automatically dampens mid-frequency system resonance. Switch selectable enable/disable.

### Anti-Resonance Phase

When anti-resonances enabled, this feature adapts the circuit to your torque/inertia ratio.

### Motor Current Control

Switch selectable to RMS or Peak current

### Motor Current

Switch selectable from 0.1 to 6.3A<sub>RMS/PK</sub> in 0.1 Amp steps.

### Idle Current Reduction

Switch selectable to *Not reduced*, *To 50%*, and *To 0%*. Motor current is reduced to selected level if a step pulse is not received for one second. Current restored to full value on next pulse.

### Resolution

Switch selectable to one of sixteen resolutions ranging from 200 to 50,800 steps per turn.

### Output Waveform

Switch selectable to allow the shaping of the microstep waveform for optimal smoothness and resolution. Pure Sine, -4%, -6% and -10% of 3rd harmonic waveforms are available.

### Current Loop Gain

Four switch selectable settings adjusts the drive to your motor's inductance value.

### Internal Power Fuses

10 Amp Slow Blow. Both Line and Neutral are fused.

### Environmental Specifications

Input Power ..... 95 to 132Vac, 50/60 Hz, 9.5 APK max.

Drive will retain control of motor down to 85Vac at reduced torque.

Operating Temp .. 32° to 122°F (0° to 50°C)

Storage Temp ..... -40° to 185°F (-40° to 85°C)

Humidity ..... 0 to 95%, non-condensing

### Motor Specifications

Type ..... 2 phase hybrid. 4, 6, or 8 lead motor

Insulation ... Minimum 500Vdc phase-to-phase and phase-to-case

Inductance .. 1 mH minimum. 2.5 to 45 mH recommended

## SD17063 Features Overview

The following section gives brief descriptions of the SD17063 settings. They are presented so that you can familiarize yourself with the drive. More in-depth descriptions are given in the Chapter 3: [SD17063 SWITCH SETTINGS](#), starting on page 17.

### Pulse Train Input

Most indexers output their directional pulses in one of two formats, *CW/CCW* or *Pulse and Direction*. By default, the SD17063 uses the *CW/CCW* format, but can be configured for either.

### Anti-Resonance

All stepper motor systems are subject to mid-frequency resonance which is the result of motor generated back-EMF. The SD17063's Anti-Resonance feature, which is enabled by default, modifies the motors current waveforms to compensate for the back-EMF which results in smoother operation at resonant speeds.

### Anti-Resonance Phase

This feature is a new addition available in the SD17063 Rev. A or B only. This new feature allows you to tune the Anti-Resonance feature to your systems inertia.

### Current Loop Gain

This new feature, available on the SD17063 Rev. A or B only, sets the gain of the current loop used to control the motor current. Its *Typical* setting will work in most systems. Reducing the gain will probably help if your motor is heavily loaded and stalling during a low speed move, or if your motor has a very low inductance value and is emitting a high frequency sound ( $\approx 10$  KHz) while powered. This setting only affects the motor when its velocity is less than or equal to 3rps.

### Current Control

This new feature, available on the SD17063 Rev. A or B only, allows you to choose *RMS* or *Peak* current control. The default setting of *RMS* means that the motors full torque is always available. If you set Current Control to *Peak* and microstep the motor, the available torque at low speeds will be reduced by up to 30%.

### Idle Current Reduction

This feature reduces current to the motor when it is idle, which significantly reduces motor heating. It has been updated on the SD17063 Rev. A or B. Three settings are now available. *To 0%* removes the motor current when it is idle. No holding torque is available. *To 50%* reduces the current to one-half its maximum value. *Not Reduced* keeps the full current applied to the motor for maximum holding torque.

### Output Waveform

This feature allows you to compensate for problems associated with a motor's physical characteristics by altering the shape of the current waveform used to drive the motor. This feature is only used when you are half-stepping or micro-stepping the motor.

### Step Resolution

The Step Resolution feature sets the number of steps needed to complete one rotation. Standard stepper motors have an inherent resolution of  $1.8^\circ$  per step. The SD17063 can further divide this  $1.8^\circ$  step by controlling the current through each motor winding. This is commonly called *microstepping*. The maximum resolution of the SD17063 is 50,800 steps per turn. Your step resolution choice is usually dependent on your application.

### Motor Current

The SD17063 can have its motor output current set from 0.1 to 6.3 amps in 0.1 amp increments. The exact current setting is based on your motor's size and application requirements. Motors that are rated for more than 6.3 amps can be used with the SD17063. The maximum current through the motor will be limited to 6.3 amps.

## SD17063 Settings Overview (continued)

### Self Test

This feature allows you to verify motor wiring and drive operation without an indexer. When the drive is set for self test, the drive rotates the motor counter-clockwise at 60 RPM with a resolution of 50,000 steps per turn.

### Indexer I/O

Figure 2.1 shows the I/O connector on the SD17063. The inputs are typically connected to an indexer, but the Reset and Disable input are sometimes connected to push buttons. The Fault Output is sometimes used to drive a solid state relay that powers a warning light instead of driving a fault input on the indexer.

All inputs are opto-coupled 5Vdc differential. The Fault Output is an isolated 30Vdc uncommitted open collector/emitter that can be wired as either a sinking or sourcing output.

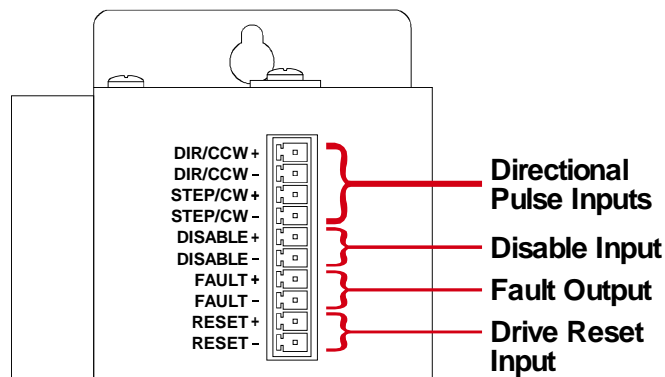

Figure 2.1 I/O Location

### Directional Pulse Inputs

Directional pulses from your indexer control the motor's position, speed, and direction of rotation. The two Directional Pulse Inputs on the SD17063 are opto-isolated and designed for 5Vdc differential signals. They can also be used as either sinking or sourcing single ended inputs by connecting one side to your power supply and driving the other side. Wiring schematics are given in the [Wiring Directional Pulse Inputs](#) section, starting on page 34.

**NOTE** A current limiting resistor must be used for voltages greater than 5Vdc. The next section, [Indexer I/O Specifications](#), lists appropriate resistor values. The resistor values are also given in the [Single Ended Input Connections](#) figure on page 35.

### Disable Input

The Disable Input shuts off the motor current when it is active. Once the Disable Input is released, the motor current ramps up to its last value instead of being applied instantaneously. Ramp up time is a maximum of 275 milliseconds. The Fault Output is active while the Disable Input is active and during the current ramp up. Like the Directional Pulse Inputs, the Disable Input can be wired as a differential, sinking, or sourcing input. Wiring schematics are included in the [Wiring Directional Pulse Inputs](#) section, starting on page 34.

**CAUTION** *DO NOT* activate the Disable Input while the motor is running. When the Disable Input is active, there is no current to the motor and the motor is free to rotate.

**NOTE** The SD17063 does not accept directional pulses when the Disable Input is active. Therefore, when the Disable Input is turned off, the drive restores current to the motor in the same phase relationship that existed before the Disable Input was turned on. If the motor turned while the Disable Input was active, (which is possible, because there is no holding torque), the motor may not re-start correctly.

**Indexer I/O (continued)**
**Reset Input**

When active, the Reset Input forces the drive into a reset state. Power is removed from the motor and the Fault Output is active while the drive is in its reset state. The drive will start to re-initialize itself *when the input is released*. Initialization will take up to 325 milliseconds. Power is restored to the motor and the Fault Output becomes inactive once the drive re-initializes correctly.

The Reset Input differs from the *Disable Input* in that the Disable Input only removes power from the motor. The Disable Input does not re-initialize the drive. Activating the Reset Input is equivalent to cycling power to the SD17063. The drive goes through its self test and updates the state of all latched switch settings.

The Reset Input circuit is identical to the Directional Pulse Inputs. The Reset Input can be wired as a differential, sinking, or sourcing input. Wiring schematics are included in the *Wiring Directional Pulse Inputs* section, starting on page 34.

**! CAUTION** DO NOT activate the Reset Input while the motor is running. When the Reset Input is active, there is no current to the motor and the motor is free to rotate.

**Fault Output**

The Fault Output is an opto-isolated 30Vdc output that is capable of driving a typical PLC input or equivalent. Both ends of the output are floating. Therefore, it can be wired as a sinking or sourcing output. Its active, or *Fault* state is *off*, meaning that the output will not conduct when the SD17063 is disabled, initializing, or a problem exists with the drive. The Fault Output's inactive, or *OK* state is *on* when the drive is operational. The output will turn off when power is removed. Therefore, a loss of power to the SD17063 will appear as an error condition.

There is a total of seven faults, called Major Faults, that trigger the Fault Output. The *Detectable Faults and Errors* section of this chapter, starting on page 14, describes these faults and how the Fault Output behaves during each of them.

**Indexer I/O Specifications**

The following tables lists the electrical specifications of the SD17063 indexer inputs and output.

Directional Pulse Inputs (STEP/CW & DIR/CCW)											
Electrical Specifications	Input Type	Opto-isolated 5 Vdc Differential									
	Input Isolation	1500 Vdc									
	Turn ON voltage and Current	5 Vdc @ 4 mA									
	Maximum Input Current	10 mAdc									
	Suggested Current Limiting Resistors	<table border="1"> <thead> <tr> <th>VDC</th> <th>R<sub>LIMIT</sub></th> </tr> </thead> <tbody> <tr> <td>5 Volts</td> <td>None</td> </tr> <tr> <td>12 Volts</td> <td>2.0 K<math>\Omega</math></td> </tr> <tr> <td>15 Volts</td> <td>2.0 K<math>\Omega</math></td> </tr> <tr> <td>24 Volts</td> <td>3.9 K<math>\Omega</math></td> </tr> </tbody> </table>	VDC	R <sub>LIMIT</sub>	5 Volts	None	12 Volts	2.0 K $\Omega$	15 Volts	2.0 K $\Omega$	24 Volts
VDC	R <sub>LIMIT</sub>										
5 Volts	None										
12 Volts	2.0 K $\Omega$										
15 Volts	2.0 K $\Omega$										
24 Volts	3.9 K $\Omega$										
Timing Specifications	Maximum Input Frequency	2 MHz									
	Minimum ON Time	200 nS									
	Minimum OFF Time	200 nS									
	Step Registration	Step taken on positive transition.									
	For STEP/DIR Directional Pulse Type Only:										
	Setup time on direction change	500 nS before first pulse									

Table 2.1 Directional Pulse Input Specifications

**Indexer I/O Specifications (continued)**

Disable and Reset Inputs											
Electrical Specifications	Input Type	Opto-isolated 5 Vdc Differential									
	Input Isolation	1500 Vdc									
	Turn ON voltage and Current	5 Vdc @ 4 mA									
	Maximum Input Current	30 mAdc									
	Suggested Current Limiting Resistors	<table border="1"> <thead> <tr> <th>VDC</th> <th>R<sub>LIMIT</sub></th> </tr> </thead> <tbody> <tr> <td>5 Volts</td> <td>None</td> </tr> <tr> <td>12 Volts</td> <td>2.0 KΩ</td> </tr> <tr> <td>15 Volts</td> <td>2.0 KΩ</td> </tr> <tr> <td>24 Volts</td> <td>3.9 KΩ</td> </tr> </tbody> </table>	VDC	R <sub>LIMIT</sub>	5 Volts	None	12 Volts	2.0 KΩ	15 Volts	2.0 KΩ	24 Volts
VDC	R <sub>LIMIT</sub>										
5 Volts	None										
12 Volts	2.0 KΩ										
15 Volts	2.0 KΩ										
24 Volts	3.9 KΩ										
Timing Specifications	Times listed are the amount of time needed from the release of the input until the SD17063 is ready to accept pulses.										
	Disable	275 milliseconds									
	Reset	325 milliseconds									

Table 2.2 Disable and Reset Input Specifications

Fault Output		
Electrical Specifications	Output Type	Opto-isolated 30 Vdc max.
	Output Configuration	Can be wired as a sinking or sourcing output.
	Output Isolation	1500 Vdc
	V <sub>CE</sub> SAT	1 Vdc @ 20 mA
	Allowable Output Current	20 mAdc max.
	Allowable Power Dissipation	20 mW max.

Table 2.3 Fault Output Specifications

**Motor Output**

Figure 2.2 shows the motor connector on the SD17063. Two phase hybrid motors with four, six, or eight leads can be wired to the SD17063. Wiring diagrams are given in the *INSTALLING THE SD17063 REV B* chapter, starting on page 38.

Internally, each motor phase is driven by a bipolar MOSFET H-bridge. The 170Vdc bus used by the H-bridges is derived from the 120Vac input power.



When the motor is powered, 170 Vdc is on the motor connector pins. To reduce the risk of electrical shock, always install the factory supplied rubber boot over the motor connector.

**Interlock Terminals**

The two **INTERLOCK** terminals are a safety feature. The SD17063 will not power the motor outputs unless these two terminals are connected by a short wire. If these terminals are not connected, the *Motor Fault* LED is on, and the *Fault Output* is active.

**Center Tap Terminals**

The two center tap pins, **A CTAP** and **B CTAP**, are for wiring convenience only. They are electrically isolated from the rest of the drive and are not used to power the motor.

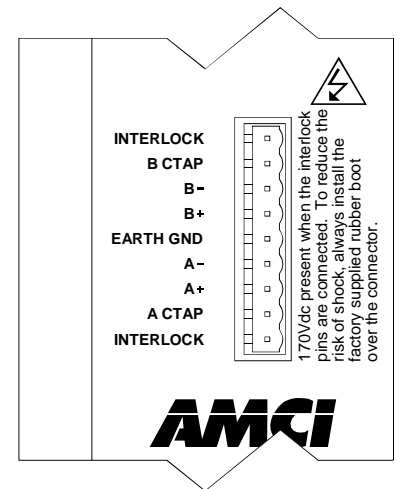

Figure 2.2 Motor Connector

## Motor Output (continued)

### EARTH GND Connection

The EARTH GND connection on the Motor Connector is for the shields of the motor's cable. This point is internally attached to the chassis and grounding lug of the SD17063.

### Motor Insulation and Inductance Specifications

Because of the high voltage bus generated by the SD17063 for the motor, be sure that the winding insulation for your motor is rated for 500 Vdc minimum. This rating applies to the phase-to-phase and phase-to-case insulation ratings. All AMCI motors meet this specification.

The ideal inductance value for a motor connected to an SD17063 is between 2.5 and 45 mH. However, the SD17063 will work with motors that have an inductance value as low as 1 mH. All AMCI motors fall within the 2.5 to 45 mH range except for the SM42 motors when they are wired in parallel.

## Input Power

Figure 2.3 shows the SD17063's power connector and grounding lug. Input power must be between 95 and 132 Vac, 50/60 Hz for proper operation. A wiring and grounding diagram is given in the [INSTALLING THE SD17063 REV B](#) chapter, starting on page 41.

### WARNING

When power is applied, 120 Vac is on the power connector pins. To reduce the risk of electrical shock, always install the supplied rubber boot on the power connector.

### NOTE

- 1) Because the SD17063 derives motor power directly from the AC line, it cannot be modified to use 230 Vac power. If your installation only has 230 Vac, you must install a step down transformer to power the SD17063. The transformer must be rated for a minimum of 1.1KVa.
- 2) Both the Neutral (N), and Line (L) terminals are internally fused with 10 amp slow blow fuses. If you plan to use external circuit breakers or fuses, they should also be rated for 10 amps.

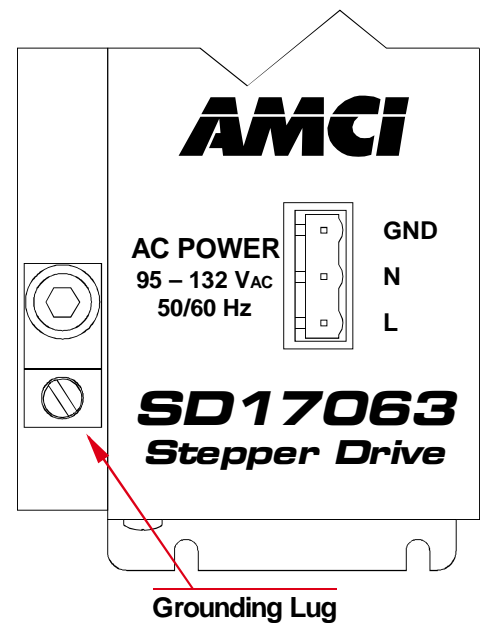

Figure 2.3 Power Connector

## Detectable Faults and Errors

The SD17063 can detect ten different faults. This section lists the state of the Indicator LED's during a fault as well as the fault's causes. Remedy suggestions are given in Appendix C, [TROUBLESHOOTING](#).

### Minor Faults

There are two faults termed *Minor Faults*. When the conditions that cause either of these faults occur, the SD17063 will miss pulses from the indexer and the motors' position may not be accurately known. The only indication that these faults have occurred is the Indicator LED's on the front panel. The Fault Output is not activated, meaning that it stays in its conductive state. Power is not removed from the motor and the drive will accept pulses from the indexer. These two faults are:

- **Velocity Step Violation:** The frequency of the directional pulses from the indexer exceeded 2 MHz. The SD17063 can sense directional pulse frequency as high as 5 MHz, but cannot control the motor current above the 2 MHz rate.
- **Window Step Violation:** The indexer sent pulses to the SD17063 while the Disable Input was active or before the 275 millisecond current 'ramp-up' period expired after The Disable Input was released. This fault also occurs if pulses are sent to the drive before it has finished initialization after the Reset Input is released. This initialization time has a maximum of 325 milliseconds.



## Detectable Faults and Errors (continued)

### Major Faults

The other seven faults are termed *Major Faults* and occur when there is a hardware fault with the drive or motor. When one of these faults occur, the Fault Output is activated, which means it doesn't conduct current. Power is removed from the motor and the drive ignores pulses from the indexer. These eight faults are:

- **Disabled:** The Disable Input is active, or motor current is ramping up after its release.
- **Reset:** The Reset Input is active, or the SD17063 has not finished initializing after its release.
- **Over Temp Fault:** The temperature of the SD17063's heat sink exceeded 95°C (200°F). This fault is latched.
- **Interlock Fault:** The two *Interlock Terminals* on the motor are not connected. This fault is latched
- **Phase-Phase Short:** There is an electrical short between two motor windings. The short exists in the motor cable or the motor itself. This fault is latched.
- **Phase-Ground Short:** One of the motor's windings is shorted to earth ground. (The Earth GND terminal of the Motor Output Connector is referenced.) The fault can be in the motor cable or the motor itself. This fault is latched.
- **Output Bus Overvoltage:** The voltage on the ±A or ±B terminals of the Motor Output Connector exceeded 250 Vdc. Usually caused by back-EMF when the motor is stopped quickly. This fault is latched.

### Fault Table

Table 2.4 lists the ten faults, the state of the Indicator LED's and the state of the Fault Output.

Fault Type	Indicator LED's				Latched Fault	Fault Output ON (OK) OFF (FAULT)
	Step	Over Temp	Motor Fault	Power		
Velocity Step Violation	Note 1	Blink	Off	On	Yes	ON
Window Step Violation	Note 1	Off	Blink	On	Yes	ON
Disabled	Off	Off	Off	On	No	OFF - Turns ON within 275 mS after the Disable Input is released.
Reset	Off	Off	Off	On	No	OFF – Turns ON within 325 mS after the Reset Input is released.
Over Temp Fault	Off	On	Off	On	Yes	OFF
Interlock Fault	Off	Off	On	On	Yes	OFF
Phase-Phase or Phase-Ground Short	Off	Off	On	On	Yes	OFF
Output Bus Overvoltage	Off	Off	Off	Blink	Yes	OFF

- 1) The Step LED flashes when valid steps are applied to the drive through the ±DIR/CCW and ±STEP/CW inputs. At low frequencies, the LED flashes at the rate of the applied steps. At high frequencies, the LED flashes at a fixed rate. When a Velocity or Window Step Violation has occurred, the drive blinks the Over Temp or Motor Fault LED's but still accepts directional pulses and drives the motor.

Table 2.4 Fault Outputs

### Clearing Latched Faults

The SD17063 will continue to indicate a latched fault even after the fault condition has ended or been removed. The only way to clear a latched fault is by activating the *Reset Input* or cycling power to the drive.

## Stepper Motors

AMCI offers a total of 21 different stepper motor configurations. Three different NEMA sizes are available, size 23, 34, and 42. The size 23 and 34 motors are available in one, two, and three stack configurations. All motors have single and dual shaft configurations, and the dual shaft models can have an incremental optical encoder factory installed. The part numbers are given below.

**NOTE** Outline drawings for all of the motors are available on our website, [www.amci.com](http://www.amci.com).

Additional information on our motors is available in Appendix A: **CHOOSING YOUR MOTOR**, starting on page 45. This information includes guidelines for sizing your motor, torque curves for all AMCI motors, and information on determining current settings for non-AMCI motors.

Specification	SM23-90	SM23-130	SM23-240	SM34-250	SM34-425	SM34-650	SM42-1250
NEMA Size	23	23	23	34	34	34	42
Max. Parallel Current	2.8A	2.8A	4.0A	4.3A	6.4A	7.7A	12.0A
Max. Series Current	1.4A	1.4A	2.0A	2.2A	3.2A	3.8A	6.0A
Holding Torque <sup>A</sup>	110 (oz-in)	160 (oz-in)	280 (oz-in)	210 (oz-in)	380 (oz-in)	496 (oz-in)	1125 (oz-in)
Motor Length w/o shafts	1.8 in.	2.2 in.	3.1 in.	2.5 in	3.7 in.	5.1 in.	7.7 in.
Rotor Inertia <sup>B</sup> (oz-in-sec <sup>2</sup> )	2.0X10 <sup>-3</sup>	3.5X10 <sup>-3</sup>	6.1X10 <sup>-3</sup>	9.1X10 <sup>-3</sup>	17.0X10 <sup>-3</sup>	26.5X10 <sup>-3</sup>	114.0X10 <sup>-3</sup>
Motor Weight <sup>B</sup>	17 oz.	24 oz.	37 oz.	48 oz.	84 oz.	124 oz.	18.6 lbs.

**For The Dual Shaft Option, Add "D" To The Given Part Number**

**For The Dual Shaft / Factory Encoder Options, Add "DE" To The Given Part Number**

- 1) The Holding Torque specification assumes that the motor is attached to an SD17063 with the windings in series, and the motor current is set to the maximum value for the motor. Using a different drive may vary your holding torque significantly.
- 2) Specification is for dual shaft motors without factory encoders.

Table 2.5 Stepper Motor Specifications

## Encoder Option

All AMCI dual shaft stepper motors can have an optical incremental encoder factory installed. A metal dust-cover that covers the encoder and shaft is installed with the encoder. Motor outline drawings that include the dimensions for the encoder are available on our website, [www.amci.com](http://www.amci.com). Table 2.6 lists the main specifications of the incremental encoder. A complete specification sheet is included with the motor when it ships with the encoder option.

Specification	Value
Resolution	1,000 lines
Output Drivers	5Vdc Differential
Input Power	135mA @ 5Vdc ± 5%
Moment of Inertia (oz-in-sec <sup>2</sup> )	17X10 <sup>-5</sup> max.
Operating Temperature	-10°C to +85°C

Table 2.6 Optical Encoder Specifications





## Choosing Your Motor

Most of your drive's settings are determined by the motor you select. This chapter assumes that you've already selected the motor and you're using this chapter to determine the appropriate drive settings. If you have not selected your motor, then refer to Appendix A: **CHOOSING YOUR MOTOR**, starting on page 45. Information in this appendix includes guidelines for sizing your motor, torque curves for all AMCI motors when attached to the SD17063, and information on determining current settings for non-AMCI motors.

## Location of Programming Switches

All of the SD17063's programmable features are set with DIP switches located on the top of the drive. As shown in figure 3.2, you gain access to these switches by loosening two screws and rotating the cover out of the way. Note that the switches are in four blocks of five switches. This manual calls the switch blocks SB1, SB2, SB3, and SB4, with SB1 nearest the front of the drive. The five switches in each block are labeled '1' through '5' with '1' nearest the front of the drive. Therefore, the third switch in the first block is SB1-3 and 'SB2-5' is the fifth switch of the second switch block.

You will also see three potentiometers towards the back of the drive, next to SB4. These potentiometers are used to calibrate the drive at the factory and should not be adjusted in the field.

With the possible exceptions of the Anti-Resonance, Anti-Resonance Phase, Current Loop Gain and Output Waveform switches, you can set the switches before actually installing the drive. These features can be used to fine tune the motor performance, but changing these settings is usually optional. The default settings will work in most systems.

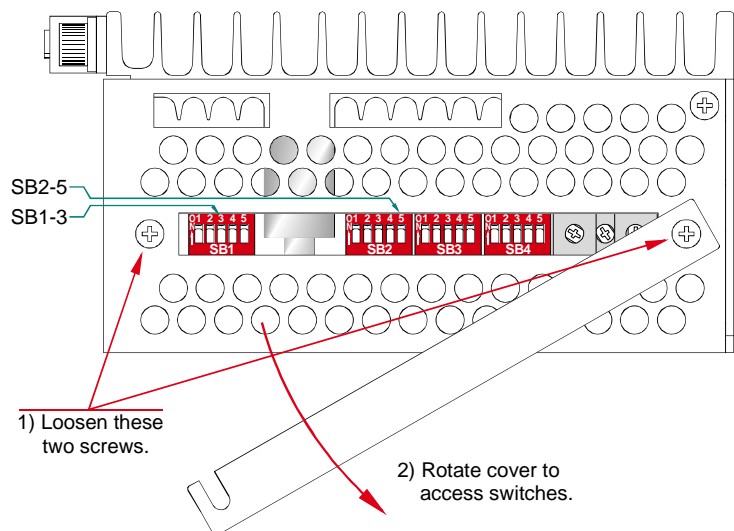

Figure 3.2 Accessing the DIP Switches

## DIP Switch Settings

Figure 3.3 on the following page shows the switch settings for features set by DIP switches SB1 and SB2. These features are:

- Pulse Train Input (SB1-1)
- Anti-Resonance Enable (SB1-2)
- Anti-Resonance Phase (SB1-3)
- Current Loop Gain (SB1-4&5)
- Current Control (SB2-1)
- Idle Current Reduction (SB2-2&3)
- Output Waveform (SB2-4&5)

Information on setting these DIP switches follows the figure. The only other features set by the switches are Step Resolution and Output Current, which are covered later in this section.

## DIP Switch Settings (continued)

<b>Motor Settings</b> Switch Blocks 1 & 2					
PULSE TRAIN INPUT		CW / CCW	CURRENT CONTROL		RMS Current
		Step & Direction			Peak Current
ANTI-RESONANCE ENABLE*		Anti-Resonance Enabled	IDLE CURRENT REDUCTION		Idle Current Reduced to 0%
		Anti-Resonance Disabled			Idle Current Reduced to 50%
ANTI-RESONANCE PHASE		Normal Inertial Load			Idle Current Not Reduced
		Low Inertial Load			Idle Current Not Reduced
CURRENT LOOP GAIN		Typical	OUTPUT WAVEFORM		Pure Sine Output
		Reduced 1			-4% Third Harmonic or SELF TEST
		Reduced 2			-6% Third Harmonic or SELF TEST
		Reduced 3			-10% Third Harmonic or SELF TEST
= Not Used When Setting Feature					
* Anti-Resonance must be DISABLED for Self Test to work.					

Figure 3.3 Motor Switch Settings

## DIP Switch Settings (continued)

### Pulse Train Input (SB1-1)

You must define the format of the directional pulses from your indexer. Directional pulses generally have one of two formats; *Step & Direction* or *CW/CCW*. Some indexers can be programmed to output either. Figure 3.4 shows the differences between the two formats and the SD17063's switch settings for each. The factory default setting is CW/CCW.

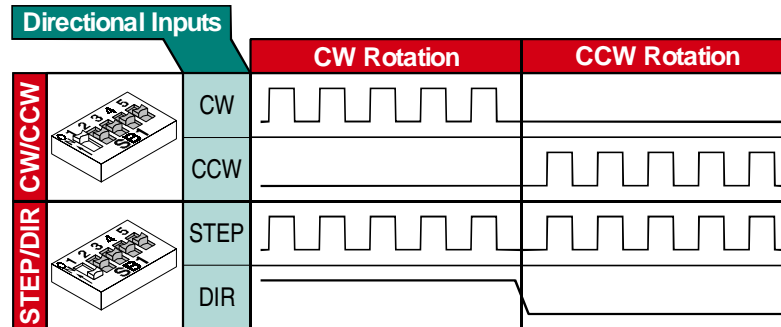

Figure 3.4 Pulse Train Types

#### NOTE

The state of the switch is latched on power up. Therefore, you must cycle power to the drive or activate the Reset Input before the drive recognizes a change to this setting.

### Anti-Resonance Disable (SB1-2)

Mid-frequency resonance, which usually occurs between 6 and 20 revolutions per second, is an inherent condition of any conventional stepping motor system. It is due to the influence of the internally generated motor back-EMF on the motor current. In this unstable range of operation, the motor experiences a velocity modulation which can become sufficiently large to cause a loss of stability and, in extreme cases, even force the motor to stall.

The drive's anti-resonance feature, which is *Enabled* by default, allows the SD17063 to modify the current waveforms to the motor to dampen the mid-frequency resonance by compensating for the back-EMF. The feature begins to work at speeds greater than three revolutions per second and has built in hysteresis, which prevents problems when the motor is running around the three revolutions per second speed.

The anti-resonance feature should be left enabled unless it causes a problem. In very rare instances, a high degree of *mechanical* resonance in your system may cause problems for the anti-resonance circuit by causing mechanical vibrations that are interpreted by the circuit as true motor speed modulations. In these cases, you will notice an increase in audible noise and a decrease in torque with this feature enabled. Before disabling the anti-resonance feature, try both settings of the anti-resonance phase feature. (See the next section.) If the system still runs better without the anti-resonance feature enabled, then disable it.

Anti-Resonance must be disabled before running the SD1763's Self Test.

### Anti-Resonance Phase (SB1-3)

This setting allows you to tune the anti-resonance feature to the inertia of your system. When left at its default setting of *Normal Inertial Load*, the SD17063 is tuned for loads with an inertia somewhere between one and ten times the inertia of the motor's rotor. If your load's inertia is less than the inertia of the motor, or your system has an extremely high torque-to-inertia ratio, then try setting the Anti-Resonance Phase to its *Low Inertial Load* setting.

The correct setting will give you the most torque between 6 rps and 20 rps. If you try the *Low Inertial Load* setting and do not see an increase in torque or smoother operation, then leave this feature at its *Normal Inertial Load* setting. As stated above, highly resonant mechanical systems may cause problems for the Anti-Resonance circuit. In these rare cases, you will see smoother operation and more torque with the Anti-Resonance circuit disabled. (See Anti-Resonance Disable section above.)

## DIP Switch Settings (continued)

### Current Loop Gain (SB1-4 & SB1-5)

Current loop gain refers to the gain of the closed loop amplifier that controls the current through the motor. Its default setting of *TYPICAL* is designed to work with motors whose inductance value is above 2.5 mH. You should use the default setting for all AMCI motors except for the SM42 when it is parallel connected to the SD17063. Non-AMCI motors that are series connected should also use the default setting. If you are parallel connecting a non-AMCI motor to the SD17063, then calculate the motor's small signal inductance. If the inductance is greater than 2.5 mH then the default *TYPICAL* setting should work with your motor. If the calculated inductance value is between 1 and 2.5 mH, the default setting will still work, but you may benefit by reducing the current loop gain.

If you are using a parallel connected SM42, you may benefit from using the *REDUCED 1* setting for the current loop gain.

If you think that you will benefit from adjusting the gain, the easiest way to determine the optimum setting is by actually testing the motor. See *Determining Current Loop Gain* starting on page 42 for the procedure to set the current loop gain.

### Current Control (SB2-1)



**NOTE** This setting has no effect if you are full stepping the motor.

Many microstepping drives control only the peak current to the motor. At low speeds, this type of current control drops the available torque when microstepping the motor to 70.7% of that available when full stepping the motor. By default, the SD17063 does not control the peak current to the motor, it controls the RMS current. This means that the current applied by the SD17063 is always the power equivalent of the full step current. Therefore, the motors' full torque is always available. In fact, depending on the motors characteristics, microstepping may even increase the available low speed torque.

RMS current is maintained down to 0.005 revolutions per second. Below this speed, the drive automatically switches to peak current to prevent motor damage. If this creates a problem with your system, choose peak current control. Be aware of the resultant drop in available low speed torque when microstepping the motor.



**WARNING** This setting is not latched. Changes to this setting are applied immediately. Be aware that changing this setting while the motor is running may cause unexpected operation because of the possible reduction in available torque.

### Idle Current Reduction (SB2-2 & SB2-3)

The SD17063 can automatically reduce the current to the motor when it is not running to significantly reduce motor heating. However, this also reduces the holding torque of the motor. If you choose an idle current reduction setting, the current will be reduced after one second has passed without a step pulse from your indexer. Once the motor receives a step pulse from the indexer, the motor current is immediately brought up to its 100% value on the first step.

Two current reductions are available. *To 0%* reduces the motor current entirely. No holding torque will be available when the motor is idle. *To 50%* reduces the motor current to one-half its maximum value. You can also use the *Not Reduced* setting to always keep the full current applied to the motor.

When possible, you should always reduce the idle current to reduce motor heating and prolong the motor's life. The only time you should choose not to reduce the idle current is when you *require* the full holding torque available from the motor.



**WARNING** This setting is not latched. Changes to this setting are applied immediately. Be aware that changing this setting while power is applied to the motor may cause unexpected operation because of the possible reduction in available holding torque.

## DIP Switch Settings (continued)

### Output Waveform (SB2-4 & SB2-5)

Physical inaccuracies in the motor, such as tolerances in windings and laminations, tend to add a third harmonic to the dynamic torque curves of a stepper motor. This additional dynamic torque is not evident when full-stepping the motor. However, this harmonic torque can have a pronounced effect when half-stepping or microstepping the motor by affecting resolution and smooth motor operation. The Output Waveform feature allows you to compensate for this unwanted third harmonic torque.

**NOTE** 

This feature is not used when full-stepping the motor. Because of this, these switches, along with the switches for the Step Resolution setting and Anti-Resonance Enable, are used to put the SD17063 in Self Test Mode. See *Self Test Mode* on page 53, for more information on using the Self Test.

The output current waveforms for half-stepping and microstepping are digitized and stored in the drives non-volatile memory. In addition to the pure sine waveform, the drive also stores three other waveforms. These three waveforms reduce the current waveform's 3<sup>rd</sup> harmonic by 4%, 6% or 10%. The state of the two Output Waveform switches determines which current waveform is applied to the motor.

By reducing the third harmonic in the motor's current waveform, you directly compensate for the additional third harmonic caused by the motor's tolerances. This increases resolution and allows smoother motor operation.

**NOTE** 

- 1) Determining the Output Waveform setting is usually done while testing the system. This is done because motor inaccuracies are usually not determined for individual motors. You may want to try all of the settings to determine which works best for your application. You may be able to do this with the SD17063's Self Test. If you are setting the Current Loop Gain, you should do this before determining the Output Waveform setting. See *Current Loop Gain (SB1-4 & SB1-5)* on page 21 to determine if you need to adjust the current loop gain.
- 2) The default Output Waveform setting is *Pure Sine*. This is because the motor runs most efficiently when powered with this waveform. Therefore, if you do not see any performance gains by using a modified waveform, or you do not need these performance gains, leave the Output Waveform setting to *Pure Sine*.
- 3) Setting the Output Waveform may also improve positional accuracy. However, if you require very fine positional accuracy, it is strongly recommended that you use some type of positional feedback from the motor to the indexer.
- 4) The state of the Output Waveform switches are latched on power up. Therefore, you must cycle power to the drive or activate the Reset Input to make the drive recognize a change to this setting.



## DIP Switch Settings (continued)

### Step Resolution (SB3-1,2,3,4)

The SD17063 offers sixteen step resolutions. Based on a 1.8° per step motor, figure 3.5 lists the available step resolutions along with the amount of rotation per indexer pulse.



The resolution that you should choose is dependent on your application and equipment. Full step resolution usually offers slightly better torque at high speeds, but microstepping offers smoother operation at all speeds.

If you're using the stepper motor to position a load, you may be able to use step resolution to simplify your indexer programming. An example of this is setting the step resolution to 36,000 when you want to rotate a table with 0.1° resolution. With this setting, the table will theoretically rotate 0.1° for every ten pulses applied to the drive. The actual amount of rotation, and its final position, depends on the motor and the holding torque it must generate, so position feedback to the indexer may still be necessary to accurately position the load.

When determining your step resolution, make sure you do not exceed the capabilities of your indexer. For example, assume your motor must rotate at thirty revolutions per second and the maximum output frequency from the indexer is 250,000 pulses per second. Dividing 250,000 pps by 30 rps equals 8,333.3 pulses per revolution. Therefore, the upper limit for the resolution setting is 5,000 steps per revolution. If you set the step resolution to 10,000 steps per turn or higher you will not be able to achieve your required speed because the indexer cannot output pulses fast enough.

The SD17063 has a maximum input frequency of 2 MHz. It has been extensively tested to motor speeds of fifty revolutions per second at all step resolutions.

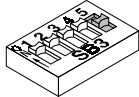
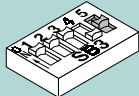
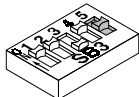
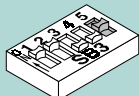
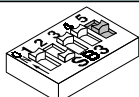
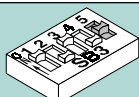
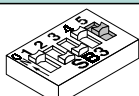
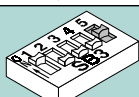
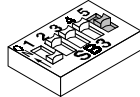
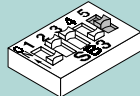
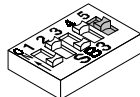
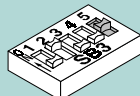
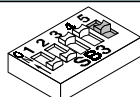
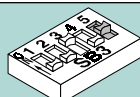
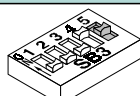
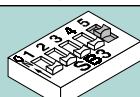
**NOTE** The state of these switches is latched on power up. Therefore, you must cycle power to the drive or activate the Reset Input before the drive recognizes a change to this setting.

Step Resolution Switch Block 3: Switches 1 - 4	
	200 Steps/Rev (FULL) or SELF TEST <sup>1</sup>
	400 Steps/Rev (HALF)
	1,000 Steps/Rev (1/5)
	2,000 Steps/Rev (1/10)
	5,000 Steps/Rev (1/25)
	10,000 Steps/Rev (1/50)
	12,800 Steps/Rev (1/64)
	18,000 Steps/Rev (0.02°)
	20,000 Steps/Rev (1/100)
	21,600 Steps/Rev (1 arc min.)
	25,000 Steps/Rev (1/125)
	25,400 Steps/Rev (1/127)
	25,600 Steps/Rev (1/128)
	36,000 Steps/Rev (0.01°)
	50,000 Steps/Rev (1/250)
	50,800 Steps/Rev (1/254)
	= Not Used When Setting Step Resolution

1) Self Test Mode is selected when the Step Resolution switches are set to 200 S/Rev, Anti-Resonance is disabled, and the Output Waveform switches are set to -4%, -6%, or -10% 3<sup>rd</sup> harmonic.

Figure 3.5 Step Resolution Switch Settings

### DIP Switch Settings (continued)

#### Motor Current (SB3-5 & SB4-1,2,3,4,5)

Your motor current setting is based on the amount of torque you need. Torque curves for our motors are available in Appendix A: **CHOOSING YOUR MOTOR**, starting on page 45. Table 3.1 gives the maximum current ratings for all of our stepper motors. In the cases of the SM34-650D and SM42-1250D, the maximum current of 6.3 amps is the limit of the SD17063, not the motor. If you do not need the maximum torque available from the motor, note that you do not have to set the current to this value. In fact, setting it to a lower value will decrease motor heating which will prolong its life.

Specification	SM23-90	SM23-130	SM23-240	SM34-250	SM34-425	SM34-650	SM42-1250
Series Current	1.4A	1.4A	2.0A	2.2A	3.2A	3.8A	6.0A
Parallel Current	2.8A	2.8A	4.0A	4.3A	6.3A	6.3A	6.3A

Table 3.1 Maximum AMCI Motor Current Settings

#### ! WARNINGS

- 1) Never increase the current setting to a value greater than that specified for the motor. Excessive current may cause motor overheating and failure.
- 2) The motor current setting is not latched. Changes to this setting are applied immediately. Be aware that changing this setting while power is applied to the motor may cause unexpected operation, including loss of holding torque. This could result in possible damage to equipment and/or injury to personnel. Therefore, AMCI can only recommend changing these settings while power is removed from the drive.

If you decide to change these switches while power is applied to the drive, **DO NOT** make changes while the motor is running.

Figures 3.6 through 3.8 show the switch settings for the motor current.

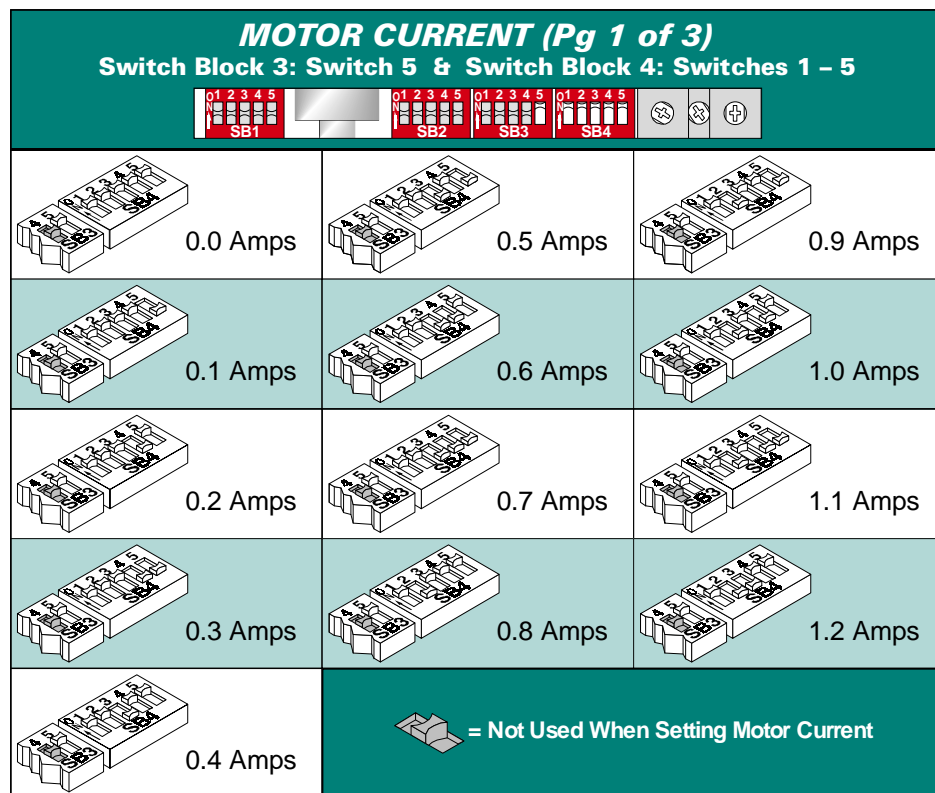

Figure 3.6 Motor Current Settings (0.0A – 1.2A)



## DIP Switch Settings (continued)

Motor Current (SB3-5 & SB4-1,2,3,4,5)

<b>MOTOR CURRENT (Pg 2 of 3)</b> Switch Block 3: Switch 5 & Switch Block 4: Switches 1 – 5		
1.3 Amps	2.3 Amps	3.3 Amps
1.4 Amps	2.4 Amps	3.4 Amps
1.5 Amps	2.5 Amps	3.5 Amps
1.6 Amps	2.6 Amps	3.6 Amps
1.7 Amps	2.7 Amps	3.7 Amps
1.8 Amps	2.8 Amps	3.8 Amps
1.9 Amps	2.9 Amps	3.9 Amps
2.0 Amps	3.0 Amps	4.0 Amps
2.1 Amps	3.1 Amps	4.1 Amps
2.2 Amps	3.2 Amps	4.2 Amps
= Not Used When Setting Motor Current		

Figure 3.7 Motor Current Settings (1.3A – 4.2A)

## DIP Switch Settings (continued)

Motor Current (SB3-5 & SB4-1,2,3,4,5)

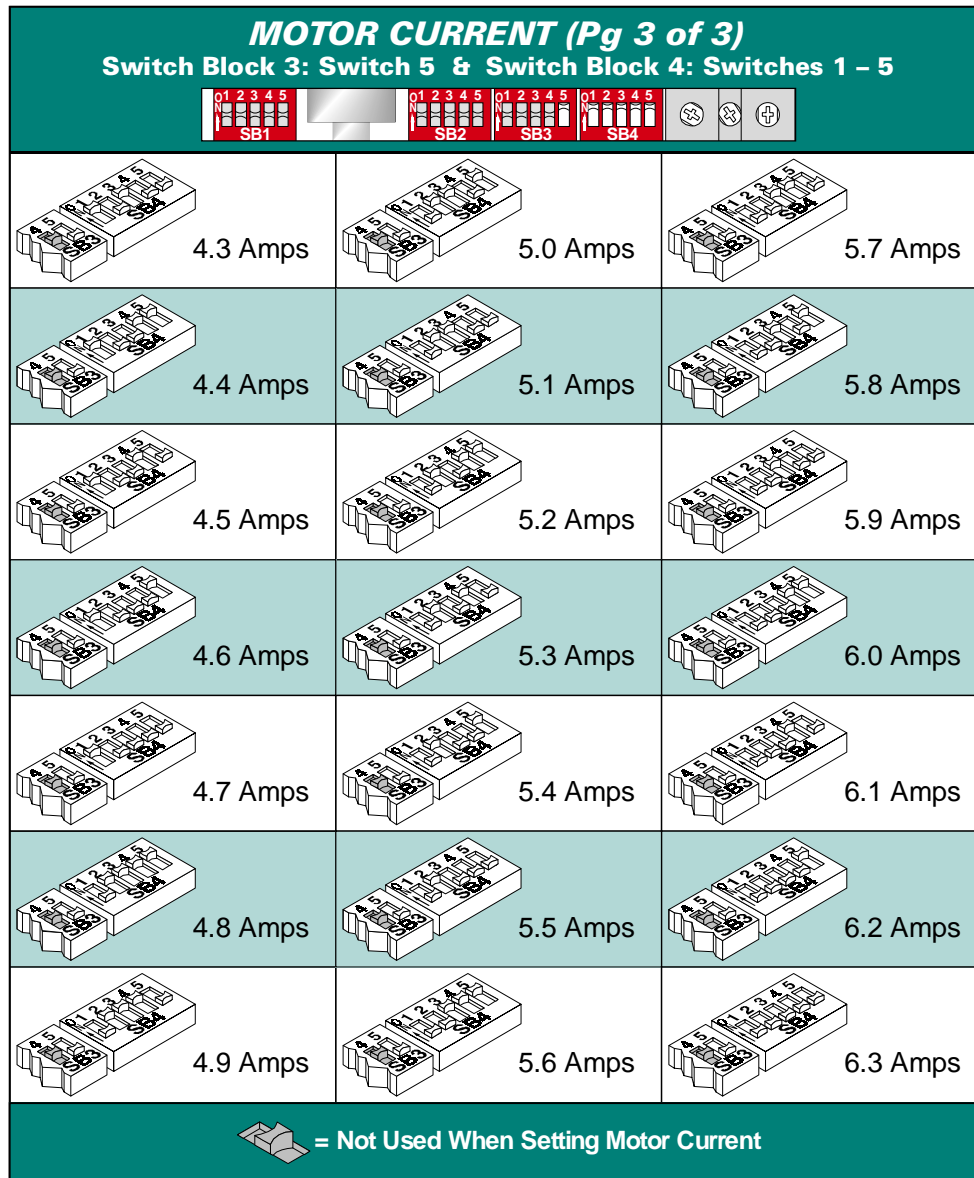

Figure 3.8 Motor Current Settings (4.3A – 6.3A)

### Self Test

The Output Waveform feature is not needed when using full step resolution. When full stepping a motor, the Pure Sine waveform is always used. Therefore, the SD17063 will enter its Self Test mode when the Step Resolution feature is set to *Full Step*, the Anti-Resonance feature is *Disabled*, and Output Waveform feature is set to any value other than *Pure Sine*.

The drive will rotate the attached motor counter-clockwise at 60 RPM with 50,000 steps per turn. The SD17063 will use the current waveform selected by the Output Waveform switches when driving the motor, either -4%, -6%, or -10% 3<sup>rd</sup> harmonic. The SD17063 will continue to drive the motor until the switches are changed and the drive is reset by the Reset Input or cycling power to the drive.

Self Test can be used to verify that the motor is wiring correctly to the drive. More information on the Self Test mode can be found in Appendix C **TROUBLESHOOTING**, starting on page 53.

# GENERAL INSTALLATION GUIDELINES

This chapter gives general information on installing electronic controls in an industrial environment including the importance of proper wiring, grounding, and surge suppression. If you are responsible for installing the SD17063, make sure you are familiar with these practices and follow them when installing the unit.

 **WARNING**

This chapter is presented as a tool in the hopes of avoiding common installation problems. It is not a substitute for the safety practices called out in local electrical codes or, in the United States, the National Electrical Code published by the National Fire Protection Association. If *any* conflicts exist, local and national codes must be followed. *It is the responsibility of the user* to determine what installation practices must be followed to conform to all local and national codes.

### **Background**

AMCI has extensively tested the SD17063, both in the lab and in the field, under a wide range of conditions to see how the unit reacts to an adverse environment. This includes testing the unit after intentionally installing it incorrectly. The results of our testing is the following list of areas that must be addressed when engineering your system. The order of the list shows the areas that have the largest impact on system operation first.

- 1) Grounding
- 2) Wiring
- 3) Surge Suppression

This list also shows the first areas that should be investigated if your installation experiences problems.

## Grounding

Proper grounding is the single most important consideration for a safe installation. Proper grounding also ensures that unwanted electrical currents, such as those induced by electromagnetic noise, will be quickly shunted to ground instead of flowing throughout the machine.

- All ground connections must be permanent and continuous to provide a low-impedance path to earth ground for induced noise currents.
- The chassis of the SD17063 must be connected to chassis ground through its mounting in the enclosure, and with a bonding wire connected to the grounding lug. This wire must be a minimum of #8 gauge and be stranded. Do not use solid wire. A 1/2" wire braid is also acceptable.
- Any non-isolated power supply attached to the SD17063 must be connected to the same chassis ground as the unit to avoid ground loops.
- All isolation transformer secondary windings that are grounded to conform to local or national codes must be grounded to the same earth ground as the machine ground.

AMCI strongly suggests the use of a ground bus in the enclosure that houses the SD17063. As shown in figure 4.1, the ground bus becomes the central grounding point for the enclosure and its equipment. The ground bus is directly connected to your grounding electrode system.

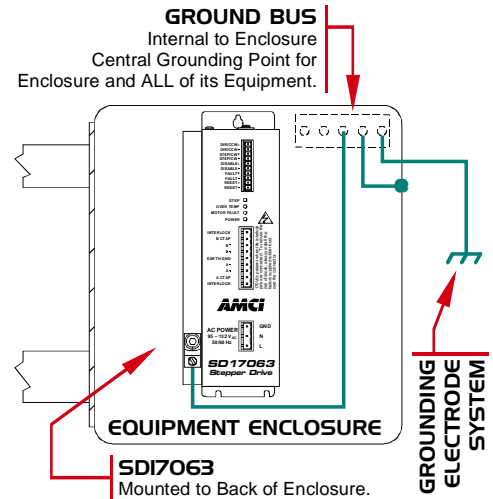

Figure 4.1 Ground Bus System

## Wiring

The most important aspect of wiring is determining the amount of voltage and power carried by the cable and separating low power cabling from high power cabling. Inside of an enclosure, separate the two types of cabling with as much physical distance as possible and keep the wiring neat. Outside of the enclosure, low and high power cabling must be run in separate conduits.

- **Indexer Cabling (Low Power)**
  - 1) Indexer Cabling includes the Directional Pulse Inputs, the Disable Input, and the Fault Output
  - 2) Signals attached to the Indexer Connector are of low voltage and low power. Indexer Cabling can be installed in conduit along with other low power cabling such as communication cables and low power ac/dc I/O lines. It cannot be installed in conduit with ac power lines, stepper motor cabling, or other high power ac/dc I/O lines.
  - 3) Each cable must be shielded and grounded only at the device that is generating the signals. If you must splice the cable, it must be done in a grounded junction box. When splicing, treat the shield as a signal-carrying conductor. Do not connect the shield to earth ground at the junction box.

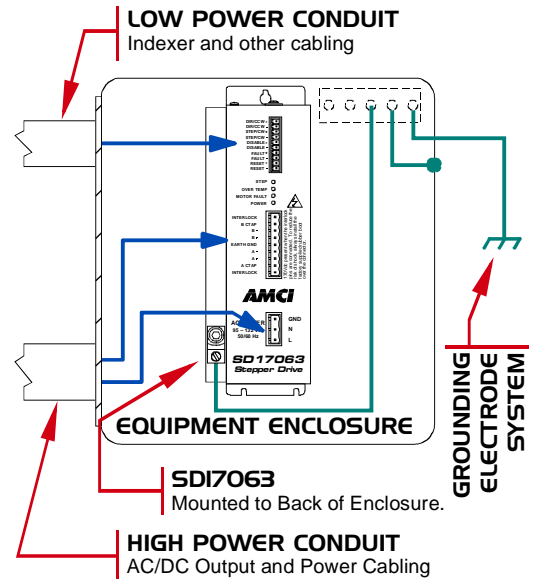

Figure 4.2 Typical Enclosure

## Wiring (continued)

### ► Motor Wiring (High Power AC & DC)

- 1) Motor Wiring must be kept separate from the indexer cabling and other low power I/O wiring in order to lessen the possibility of coupling transient noise into the low power cabling.
- 2) If a conduit containing the indexer cabling or other low power wiring must cross conduit that contains motor wiring, they must cross at right angles.

### ► AC Power Wiring (High Power AC & DC)

- 1) Power Wiring must be kept separate from the indexer and input wiring in order to lessen the possibility of coupling transient noise into the low power cabling.
- 2) If a conduit containing the indexer cabling or other input wiring must cross conduit that contains power wiring, they must cross at right angles.
- 3) Whenever possible, conduit that contains low power cabling must be kept 1 foot (30 cm) away from 120Vac conductors, 2 feet (61 cm) from 240Vac conductors, and 3 feet (91 cm) from 480+ Vac conductors.

## Surge (EMI) Suppression

All inductive devices in the system, such as motor starters, contactors, relays and solenoids, must have surge suppression devices installed across their coils. This limits the amount of electrical noise that may be coupled into any low power cabling near the inductive devices. In the case of the SD17063's indexer cabling, this lowers the chances that electrical noise will appear as directional pulses to the drive.

Devices that must be suppressed includes all devices that share an AC power connection with the SD17063 and its indexer, have wiring in the enclosure that houses the SD17063 or indexer, or wiring that is run in the same conduit as indexer wiring. DC loads are typically suppressed with a flyback diode, while AC loads are typically suppressed with a RC network or varistor.

### ► RC Networks are the preferred suppressor for AC loads

The figure below show where surge suppression devices should be placed in the circuit.

#### Acceptable Connection

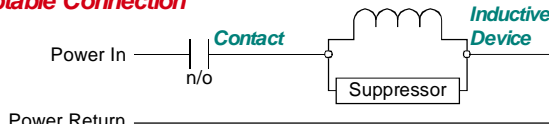

The acceptable connection suppresses noise at its source. The wiring that connects the load to the power supply and contacts will not radiate noise when the load is switched and noise will not be coupled into the power supply.

#### Un-Acceptable Connection 1

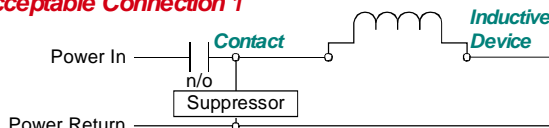

This connection protects the power supply and contact, but allows noise to radiate through the load's wiring where it can be coupled into other cables around it.

#### Un-Acceptable Connection 2

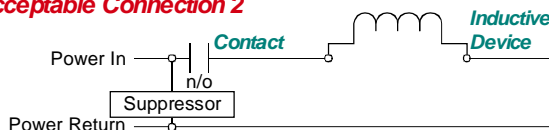

This connection protects the power supply but nothing else. Noise can radiate through the load's wiring where it can be coupled into other cables around it and the contact may eventually be damaged by high voltage inductive spikes.

#### Un-Acceptable Connection 3

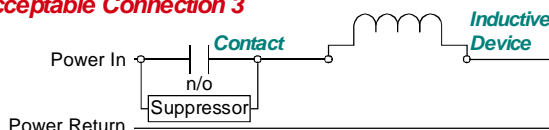

This connection protects the contact but nothing else. Noise can radiate through the load's wiring where it can be coupled into other cables or into the power supply. Noise in the supply may affect any device powered by it. Also, if the suppressor shorts out, the load will always receive power.

Figure 4.3 Installing Surge Suppression Devices

## Surge (EMI) Suppression (continued)

### Surge Suppression: DC Outputs

All inductive DC loads require a commutating, or “fly-back” diode across the load. Inductive DC loads include relays, solenoids, and DC motors.

Unlike resistors, diodes have a polarity and only conduct current in one direction. Therefore, care must be taken when installing diodes. As shown in the figure below, the *cathode* of the diode, which is denoted by the white or black band on one end of the diode, must be installed on the positive side of the load. If you install the diode backwards, it will most likely destroy itself as soon as you apply power to the load.

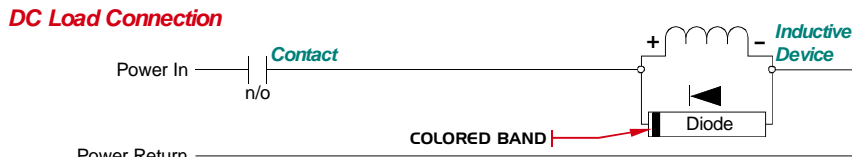

Figure 4.4 DC Output Surge Suppression

- The diode must be sized to handle the inductive surge of the load when it turns off.
- Some devices can be ordered with built in fly-back diodes, or the device manufacturer will offer suppressors designed specifically for the device. These types of devices are strongly recommended.

### Surge Suppression: AC Outputs

If you are also switching AC loads with hard contacts such as mechanical relays or contactors, then you must install a suppression network on the load switched by these hard contacts. The two most common suppressors for AC loads are varistors and R-C networks.

- **AMCI strongly suggests R-C networks for all AC applications.**

A varistor is a solid state device that turns on and conducts when the voltage across its terminals exceeds its rated value. Herein lies the problem with using a varistor as an AC suppressor. The voltage (problem) must be generated before the varistor responds. In our testing we have found that hard contacts will still arc when a varistor is placed across an AC load. This arcing is due to the fact that the breakdown voltage of the air between the contacts when they first open can be less than the rated voltage of the varistor. If the instantaneous AC voltage applied to the contacts is above the breakdown voltage of air, but less than the rated voltage of the varistor, the contacts will arc.

On the other hand, an R-C network acts as a low-pass filter, instantaneously dampening fast transients when they occur. The main drawback of R-C networks is that they are harder to correctly specify than varistors. Varistors only require you to specify breakdown voltage and power dissipation ratings. R-C networks require you to balance the need of suppression when the contacts open against the amount of surge current the relay can tolerate when the contacts close. Table 4.1 shows the trade-offs you must be aware of when specifying R-C networks.

	When Contacts Close	When Contacts Open
Low Resistance, High Capacitance	Higher surge current through relay contacts to charge capacitor. (Negative)	Lower transient voltage spike. (Positive)
High Resistance, Low Capacitance	Lower surge current through relay contacts to charge capacitor. (Positive)	Higher transient voltage spike. (Negative)

Table 4.1 R-C Network Trade-offs

In general, capacitor values range from 0.1 to 1.0  $\mu\text{F}$  and resistor values range from 150 to 680 ohms.

The easiest way to specify a R-C network is by following the recommendations of the load’s manufacturer. Most manufacturers have tested and specify standard R-C networks, and many sell networks that are designed to integrate with their products. If you cannot get help from your load’s manufacturer, feel free to contact AMCI for assistance.



# INSTALLING THE SD17063 REV B.

### **Installing the SD17063**

Installing the SD17063 is broken down into six steps.

- Step 1: Installing the Drive
- Step 2: Connecting the Indexer
- Step 3: Installing the Stepper Motor
- Step 4: Connecting the Motor
- Step 5: Grounding and Powering the System
- Step 6: Testing the System

If the SD17063 is new to you, consider running the drive's *Self Test* on a bench to familiarize yourself with the drive before installing it. Information on using the Self Test can be found in Appendix C, **TRUBLE-SHOOTING**, starting on page 53.

### **A Note On Grounding**

Effective grounding of the stepper motor and SD17063 drive is critical to safe and proper operation.

 **WARNING** The SD17063 must be connected to earth ground. Failure to properly ground the chassis leaves the potential for severe electrical hazard and/or problems with normal operation.

The chassis ground connection of the SD17063 and the body of the motor are connected through the shield of the motor's cable. When installing the system, take steps to ensure that the earth grounds of the two are at the same potential. Ideally, the motor and drive will be connected to the same ground bus.

Information on grounding the motor and SD17063 is given in the *Grounding* section chapter 4 on page 28, along with the *Mounting the Motor* and *Step 5: Grounding and Powering the System* sections of this chapter on pages 37 and 41 respectively.

### **Step 1: Installing the Drive**

#### **Selecting a Location**

Like most stepper drives, the SD17063 needs to be installed in a NEMA enclosure to protect it from the factory environment. Most installations place the drive in the same cabinet as the indexer or other control logic and run long cables to the motor. However, this type of installation can suffer from three problems.

- 1) The motor's cable will carry a significant amount of current, and the longer the cable, the more power will be lost to cable resistance. This will decrease the available torque from the motor.
- 2) The motor current is switched at 20KHz, which will generate a significant amount of electrical noise. Therefore, EMI is a potential problem, especially if the motor cable is not properly installed.
- 3) In order to detect motor faults, the earth ground connections of the motor and the SD17063 must be tied together. A long cable run between the indexer and motor increases the likelihood of a ground loop.

To limit these problems, consider mounting the SD17063 in an enclosure that is as close to the motor as possible. The drive's differential I/O is designed for long cable runs. Installing the SD17063 as close to the motor as possible will limit the three problems listed above.

#### **Dimensional Drawing**

The dimensional drawing of the SD17063 is given on the following page. The drive is designed to be panel mounted in one of two ways. Properly mounting the drive to a metal panel will allow a large amount of heat to be dissipated by the panel. This will result in a lower operating temperature for the drive.

The preferred way of mounting the drive is by the four bolt holes on the back of it. They accept #10-32 bolts. The maximum length of the bolt is based on the thickness of your mounting plate and is given in the figure. If it is impossible to mount the drive this way, the second mounting option uses the mounting tabs at the top and bottom of the drive. They accept #6 bolts, one at the top and two at the bottom.

**Step 1: Installing the Drive (continued)**  
**Dimensional Drawing (continued)**

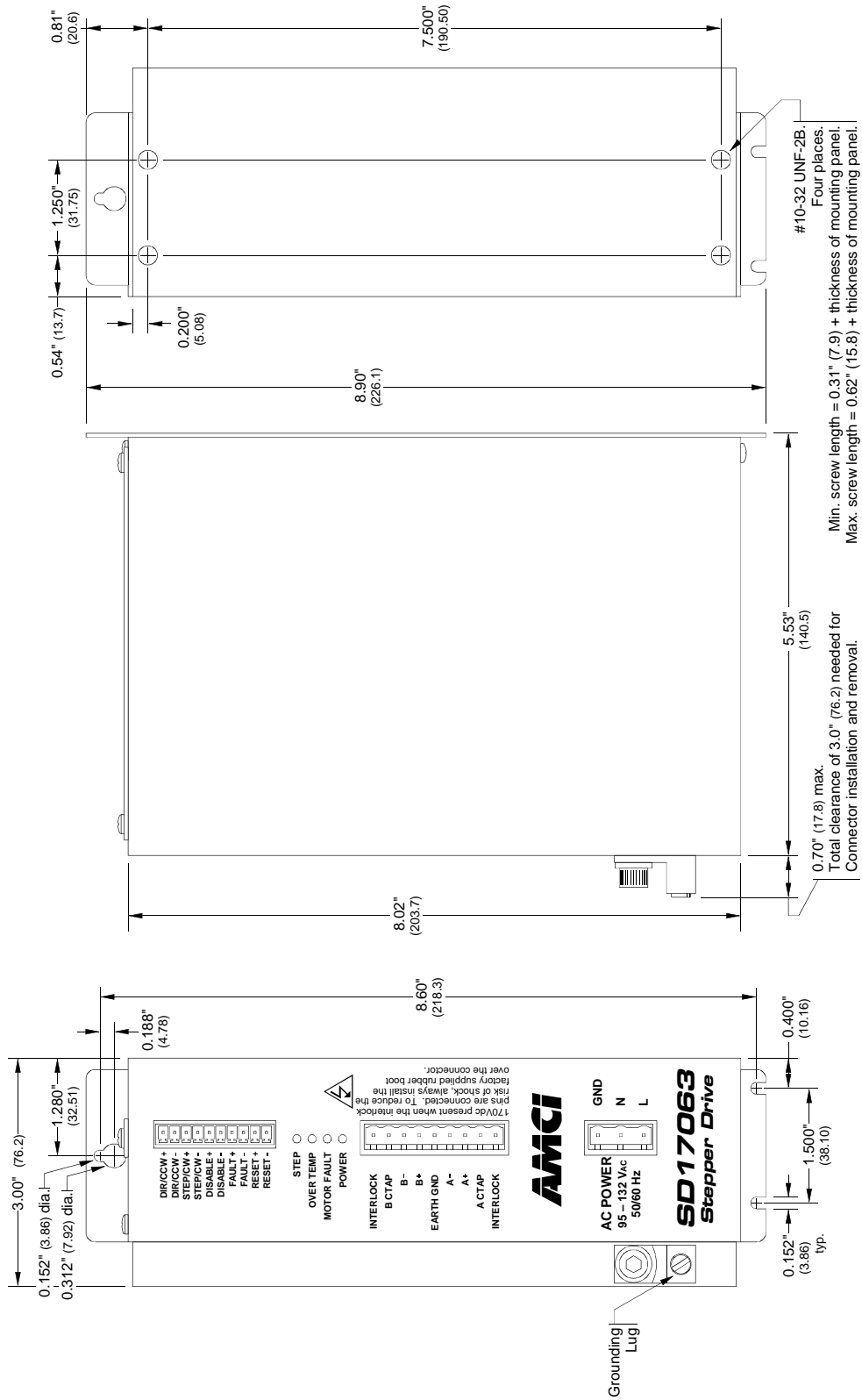

Figure 5.1 SD17063 Mounting Dimensions



## Step 1: Installing the Drive (continued)

### Clearance Dimensions

In order to assure proper convectional airflow around the SD17063, you must follow the clearance guidelines given in figure 5.2. If you don't have this amount of area around the drive, you may need to install a small fan below it to force air up through the drive.

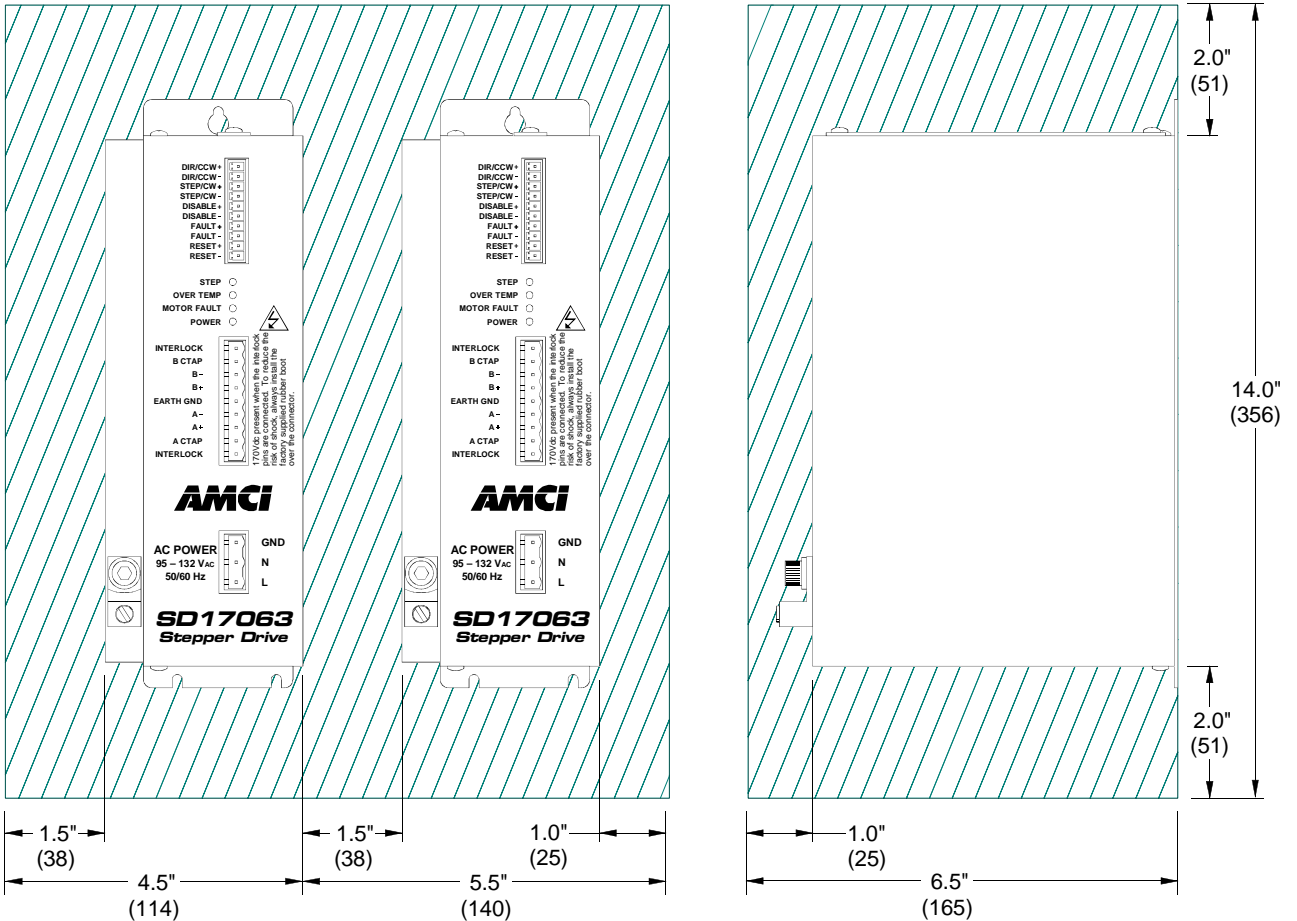

Figure 5.2 Mounting Clearance Dimensions

### Installation Notes

- In order to dissipate heat correctly, the SD17063 must be mounted with the heat sink fins vertical, as shown in figure 5.2. A large amount of heat can also be dissipated through the back panel if the drive is securely mounted to a metal panel.
- The ambient temperature around the drive must not exceed 120°F (50°C).
- If mounting the drive in an enclosure, you must make provisions for proper air flow. The clearance dimensions given in figure 5.2 should be sufficient for most applications, but a small fan mounted below the drive to force air through it may be needed if the ambient temperature is high or the enclosure is not ventilated.
- Never block the fins of the heat sink.
- Never expose the SD17063 to liquids, including condensing humidity.
- Never expose the SD17063 to metal particles. If the SD17063 is mounted in a ventilated enclosure, the ventilation fans should have dust covers.



- **WARNING** Never open the drive. Opening the drive will void the factory warranty.
- Never probe the drive. Hazardous voltages are present within the drive and digital ground is isolated from earth ground.

## Step 2: Connecting the Indexer

### NOTE

- 1) All of the Indexer I/O connections are low power, low voltage signals. All cabling must be done with twisted pair wires with an overall shield. Belden 9729 instrumentation cable is one example of an acceptable cable.
- 2) Cable from the indexer can be installed in conduit along with other low power cabling such as communication cables and low power ac/dc I/O lines. It cannot be installed in conduit with cabling from the stepper motor, ac/dc power lines or high power ac/dc I/O.
- 3) The shields of the cables must be grounded at the indexer only! When installing the cable, treat the shield as a signal carrying conductor. Do not connect the shield to earth ground at any junction box or the SD17063. This will eliminate ground loops that could damage the SD17063 or indexer.

### Wiring Directional Pulse Inputs

The indexer, also called the controller, supplies the directional pulses to the drive. One example of an indexer is the Allen-Bradley 1746-HSTP1 Stepper Controller Module for the SLC 500 programmable controller. A similar module exists for most programmable controller systems. The 1746-HSTP1 module will be used as an example.

The SD17063's Indexer Connector, along with the connections to the 1746-HSTP1, is shown in figure 5.3. The HSTP1 outputs 5 Vdc differential signals that the SD17063 is designed to accept. If your indexer outputs a differential signal that is greater than 5 Vdc, you need to install current limiting resistors in series with the input. The resistor values are given in figure 5.4.

Note that the HSTP1 will output CW/CCW pulses by default. Therefore, the Pulse Train Input DIP switch, SB1-1, should be set to zero when using this module.

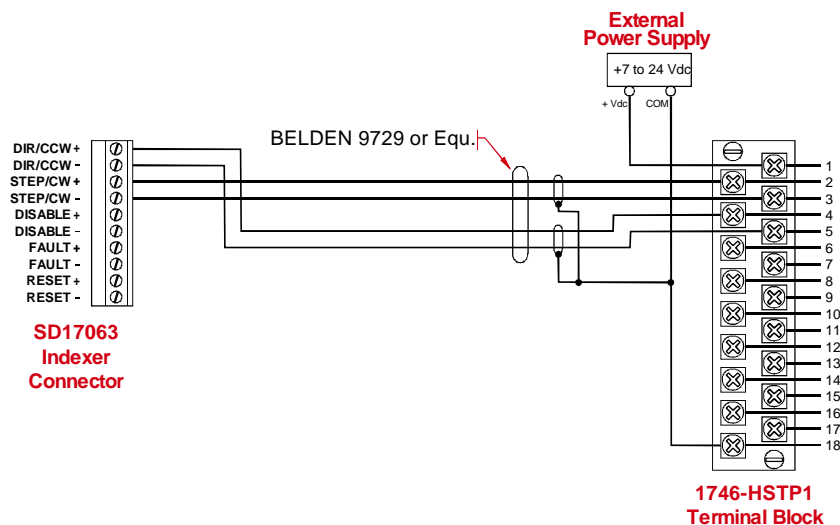

Figure 5.3 Directional Pulse Connections

Most indexers do not have 5 Vdc differential outputs. Figure 5.4 on the following page shows how to wire a single ended sourcing or sinking output to the SD17063. Note that current limiting resistors must be installed for voltages above 5 Vdc. The table in the figure gives appropriate resistor values.

## Step 2: Connecting the Indexer (continued)

### A-B MicroLogix 1500

Many customers have started to use the Allen-Bradley MicroLogix 1500 as an indexer. The MicroLogix 1500 has a Pulse Train Output (PTO) Instruction that can be used to generate directional pulses to the SD17063. This instruction controls one output that generates the STEP pulses while your ladder logic controls an output that selects the DIRECTION.

Outputs on the MicroLogix 1500 must be 24 Vdc. You can wire the outputs as either sinking or sourcing and you *must* use the 3.9KΩ resistor as shown in figure 5.4. With the directional pulses being in the STEP&DIR format, the SD17063's Pulse Train DIP switch, SB1-1, should be set to one when using the MicroLogix 1500.

#### Open Collector Sourcing Output

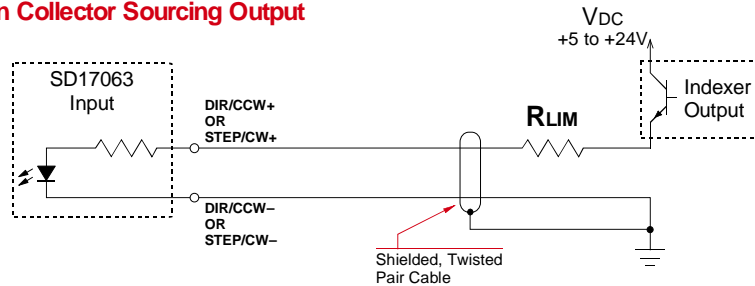

#### Open Collector Sinking Output

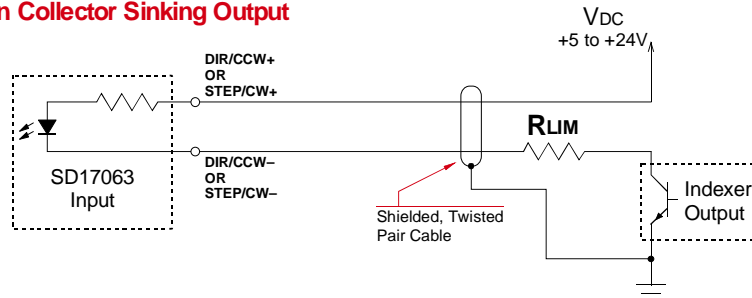

V <sub>DC</sub>	R <sub>LIMIT</sub>
5 Volts	None
12 Volts	2.0 KΩ
15 Volts	2.0 KΩ
24 Volts	3.9 KΩ

Figure 5.4 Single Ended Input Connections

### Disable Input Wiring

The ±Disable Input on the SD17063 will shut off motor current when active. The circuitry of this input is identical to the directional pulse inputs. Refer to figures 5.3 and 5.4 when wiring this input. A momentary or SPST switch can be used in place of the open collector output shown in figure 5.4.



Do not activate the Disable Input while the motor is running. When the Disable Input is active, the current to the motor is removed, and the motor is free to rotate. No holding torque is available while the Disable Input is active.

The SD17063 does not accept directional pulses while the Disable Input is active. Therefore, when the Disable Input is turned off, the drive restores current to the motor in the same phase relationship that existed before the Disable Input was turned on. If the motor rotated while the Disable Input was active, (which is possible, because there is no holding torque), the motor may not start up correctly.

The SD17063 immediately drops the motor current to zero when the Disable Input is activated, but “ramps up” the current when the Disable Input is released. This ramp up time lasts for a maximum of 275 milliseconds. Directional Pulses are not accepted until the current ramp up is complete. If you send directional pulses to the SD17063 before the 275 milliseconds have expired, the drive shows a *Window Step Violation* fault. The Motor Fault LED will blink to indicate this fault but the drive will still operate and accept directional pulses. For more information on the Window Step Violation, refer to *Minor Faults* on page 14.

**Step 2: Connecting the Indexer (continued)**

**Disable Input Wiring (continued)**

The Fault Output is active, (it will not conduct current), when the Disable Input is active and the fault output remains active during the current ramp up time. Therefore, you can use the Fault Output to signal when the drive is ready to accept pulses instead of timing out the 275 milliseconds. (The active state of the Fault Output is *off*. Therefore, a loss of power appears as a fault condition.)

**Reset Input Wiring**

The ±Reset Input on the SD17063 resets the drive when active. The circuitry of this input is identical to the directional pulse inputs. Refer to figures 5.3 and 5.4 when wiring this input. A momentary or SPST switch can be used in place of the open collector output shown in figure 5.4.

After changing the Pulse Train Input, Output Waveform, or Step Resolution DIP switches, you can activate the Reset Input to force the SD17063 to accept these changes instead of cycling power to the drive. You can also clear *Major Faults* by activating this input instead of cycling power.



Do not activate the Reset Input while the motor is running. When the Reset Input is active the current to the motor is removed and the motor is free to rotate. No holding torque is available while the Reset Input is active.

The Fault Output is active, (it will not conduct current), when the Reset Input is active and the fault output remains active during the 325 milliseconds after the release of the Reset Input that is needed to initialize the drive. Therefore, you can use the Fault Output to signal when the drive is ready instead of timing out the 325 milliseconds. (The active state of the Fault Output is *off*. Therefore, a loss of power appears as a fault condition.) Sending pulses to the drive before this initialization time has expired will result in a Window Step Violation. See *Minor Faults* on page 14 for more information on the Window Step Violation fault.

**Fault Output Wiring**

The ±Fault Output is an optically isolated transistor capable of driving a typical DC PLC input or equivalent. As shown in figure 5.5, both ends of the output are floating. Therefore, you can connect the fault output in a sourcing or sinking configuration.

The Fault Output conducts when the drive is operating normally and shuts off when the drive is disabled by the Disable Input, initializing due to the Reset Input or when powering up, or whenever a major fault occurs. *Detectable Faults and Errors*, starting on page page 14 lists the conditions that trip the Fault Output.

**Open Collector Sourcing Output**

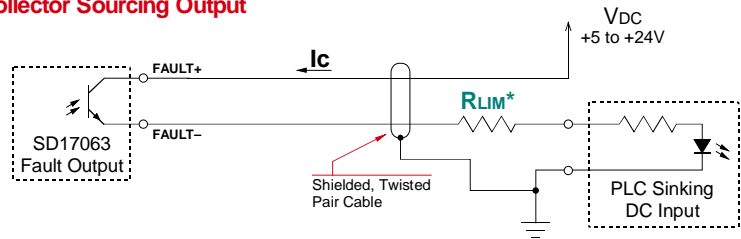

**Open Collector Sinking Output**

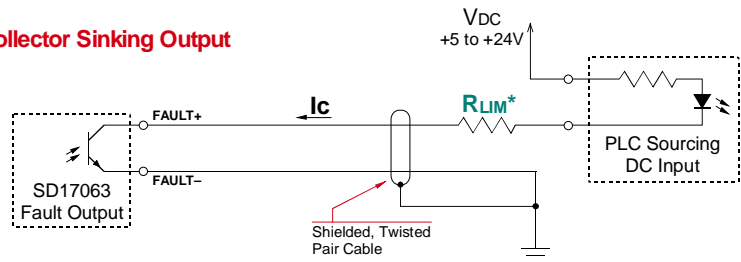

**FAULT OUTPUT Electrical Specifications**

- V<sub>DC</sub> max: 30Vdc
- V<sub>CE SAT</sub>: 1Vdc @ 20 mA
- I<sub>c</sub> max: 20 mA
- Power Dissipation: 20 mW max.

**\*R<sub>LIM</sub>**

A resistor may be needed to limit the current through the Fault Output. The value, and power rating of the resistor is dependent on the value of V<sub>DC</sub>, the voltage drop across the input, and the current requirements of the input.

Figure 5.5 Fault Output Connections

## Step 3: Installing the Stepper Motor

### Outline Drawings

Outline drawings for all of our motors can be found on our website, [www.amci.com](http://www.amci.com), in the *Document Download* section. They're available in two formats, AutoCad DWG and high resolution JPG. JPG files can be viewed in most web browsers. If you do not have internet access contact AMCI and we will fax the information to you.

### Mounting the Motor

All AMCI motor have flanges on the front of the motor for mounting. This flange also acts as a heatsink, so motors should be mounted on a large, unpainted metal surface. Mounting a motor in this fashion will allow a significant amount of heat to be dissipated away from the motor, which will increase the motor's life by reducing its operating temperature. If you cannot mount the motor on a large metal surface, you may need to install a fan to force cooling air over the motor.

Motors should be mounted using the heaviest hardware possible. AMCI motors can produce high torques and accelerations that may weaken and shear inadequate mounting hardware.

#### NOTE

- 1) The motor case must be grounded for proper operation. This is usually accomplished through its mounting hardware. If you suspect a problem with your installation, such as mounting the motor to a painted surface, then run a bonding wire from the motor to a solid earth ground point near it. Use a minimum #8 gauge stranded wire or 1/2" wire braid as the grounding wire
- 2) Do not disassemble *any* stepper motor. A significant reduction in motor performance will result.
- 3) Consult with AMCI before machining motor shafts. AMCI has machining capability that may allow you to order the motor as a custom product. Damaging a motor by improperly modifying a motor's shaft will void its warranty.

### Connecting the Load

Care must be exercised when connecting your load to the stepper motor. Even small shaft misalignments can cause large loading effects on the bearings of the motor and load. The use of a flexible coupler is *strongly* recommended whenever possible.

### Extending the Motor Cable

#### CAUTION

The shield of the motor cable is connected to the case of the motor and is usually connected to earth ground at the motor through the motor's mounting. The shield is also connected to earth ground at the SD17063. Extending the motor cable will greatly increase the chances of forming a ground loop between the motor and the SD17063. Ideally, the motor and SD17063 should use the same ground bus.

Even though it is possible to extend the cable length an additional forty feet, AMCI recommends installing the SD17063 as close to the motor as possible. This will decrease the chances of forming a ground loop, and has the added benefit of limiting the amount of power loss in the motor cable. If you must extend the cable, you should use a cable with twisted pairs 18 AWG or larger and an overall shield. For SM42's use 14 AWG+ cable. Belden 9554 (eight wire), 9553 (six wire) and 9552 (four wire) meet these specifications for 18 AWG+. Belden 1070A (eight wire), 1527A (six wire) and 1069A (four wire) meet these specifications for 14 AWG+.

### Installing the Motor Cable

#### NOTE

- 1) All of the motor connections are high power, high voltage signals. Cable from the motor can be installed in conduit along with ac/dc power lines or high power ac/dc I/O. It cannot be installed in conduit with low power cabling such as cabling from the SD17063 to the indexer, communication cables, or low power ac/dc I/O lines.
- 2) If you decide to extend the motor cable, treat the shield as a signal carrying conductor when installing the motor cable. Do not connect the shield to earth ground at any junction box.

## Step 4: Connecting the Motor

### Motor Connector

The motor connector is shown in figure 5.6. The two Interlock terminals are a safety feature. When these two terminals are not connected, the drive will not power the motor outputs, and the drive turns on the Motor Fault LED and the Fault Output. For normal operation, these two terminals must be connected together with a short wire.

The two center tap pins, A CTAP and B CATP, are there for wiring convenience only. They are electrically isolated from the rest of the drive and are not used to power the motor. The **EARTH GND** pin is for the shields of the motor cable. This pin is directly connected to the grounding lug of the SD17063.

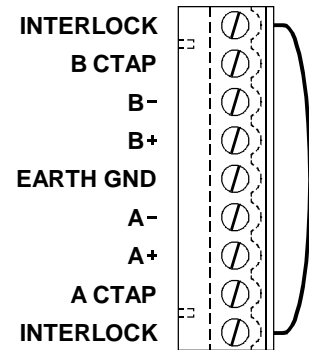

Figure 5.6 Motor Connector with Interlock Jumper

**NOTE**

When powered, the motor connector represents a shock hazard because it has 170 Vdc present on its terminals.

A rubber boot that is included with the connector must be installed but is not shown in the following figures for clarity. When installing the motor cable, slide the rubber boot onto the cable before wiring the connector. When you're sure the wiring is correct, slide the boot over the connector to cover the screw heads.

**! WARNINGS**

- 1) Always remove power from the SD17063 before connecting or disconnecting the motor.
- 2) Never connect the motor leads to ground or to a power supply.
- 3) Always verify that the motor case is connected to the cable shields before operation
- 4) Always connect the cable shield to the Earth Ground terminal of the SD17063's Motor Connector.

### SM42 Wiring

The SM42 motors are eight lead motors, but only four wires are brought back to the SD17063. A terminal block, located underneath the back cover of the motor, is used to wire the motor in series or parallel. With these connections made at the motor, you only need to bring the  $\pm A$  phase and  $\pm B$  phase connections to the drive. Once you make the terminal block connections, refer to figure 5.7 *Four Lead Motor Connection* on the following page to connect the SM42 to the SD17063.

To access the wiring terminals, remove the back cover of the SM42. Table 5.1 below shows how to connect the terminals to wire the motor in series or parallel. Connections must be made with 14 AWG wire or larger.

Jumpers	A Winding	B Winding
Series Connection	6 to 2	7 to 8
Parallel Connection	1 to 2 3 to 6	7 to 4 5 to 8

Table 5.1 SM42 Terminal Connections

You must also connect the cable shields to the body of the SM42. The grounding screw is located behind the back cover on the body of the motor, just below the conduit fitting. The grounding screw is neither of the ones used to attach the plastic terminal block to the motor.



## Step 4: Connecting the Motor (continued)

### Four Lead Motors

As shown in figure 5.7, a four lead motor can be connected to the SD17063 in only one way. Many four lead motors, including AMCI's SM42 motors, have eight wires inside the motor. These wires are connected in series or parallel in the motor, and four leads are brought out to the drive.

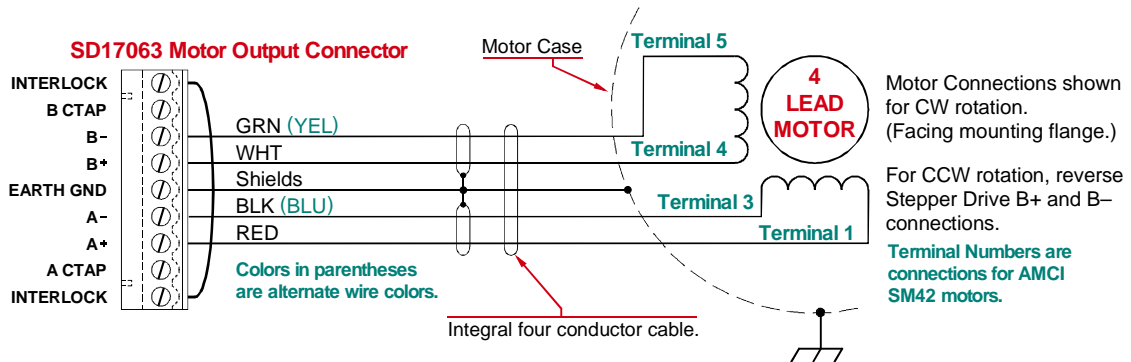

Figure 5.7 Four Lead Motor Connection

### Six Lead Motor

As shown in figure 5.8, a six lead motor can be connected to the SD17063 in two ways. A *Series Connected* motor offers more torque than a *Center Tap Connected* motor at low speeds, but usually offers lower torque at high speeds. However, the operating temperature of a center tap connected motor is always higher than a series connected motor.

Note that the A CTAP and B CTAP pins on the motor connector are not powered and are for wiring convenience only. A Center Tap Connection is equivalent to a unipolar connection because only half of the winding is used.

#### Six Lead Series Connected

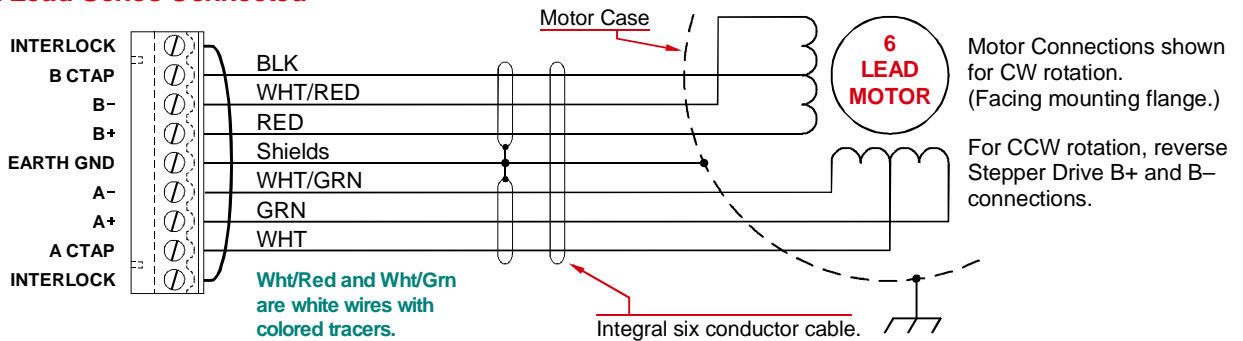

#### Six Lead Center Tap Connected

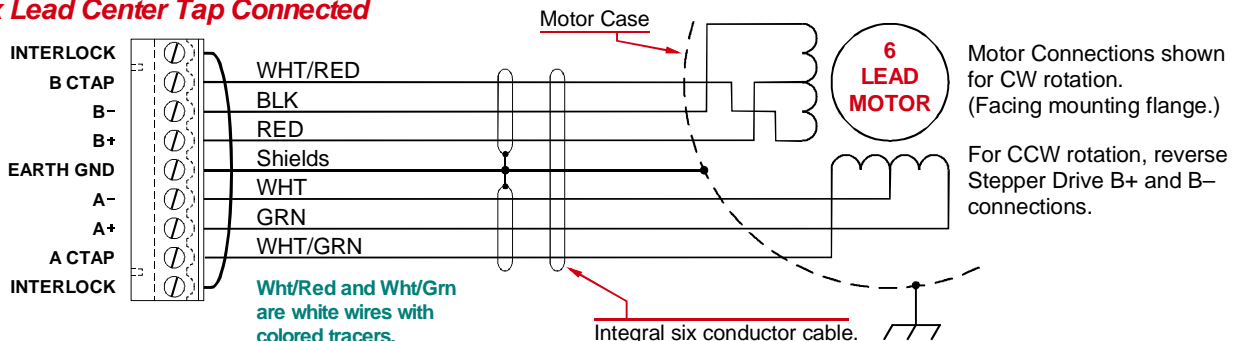

Figure 5.8 Six Lead Motor Connections

## Step 4: Connecting the Motor (continued)

### Eight Lead Motor

As shown in figure 5.9, an eight lead motor can be connected to the SD17063 in two ways. A *Series Connected* motor may offer more torque than a *Parallel Connected* motor at low speeds, but a parallel connected motor will always offer higher torque at high speeds. The operating temperature of a parallel connected motor is always higher than a series connected motor.

#### Eight Lead Series Connected

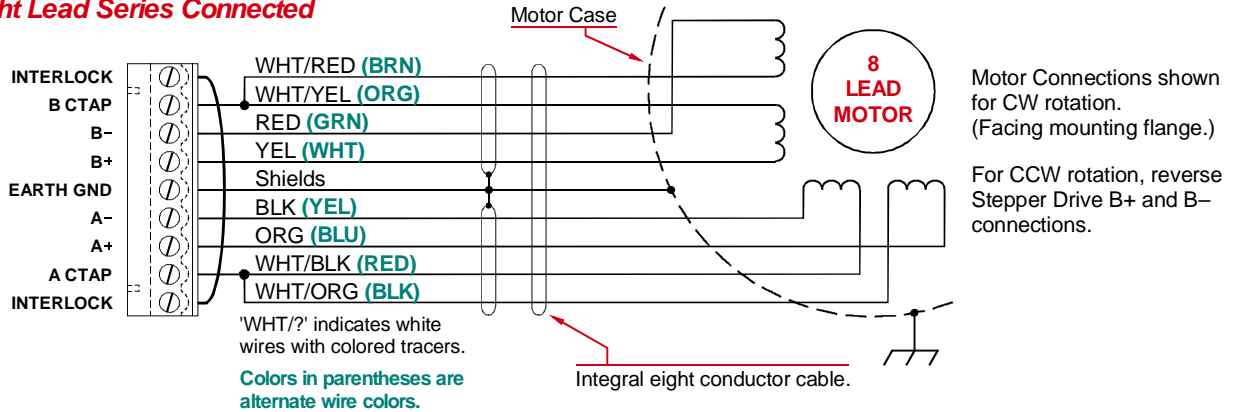

#### Eight Lead Parallel Connected

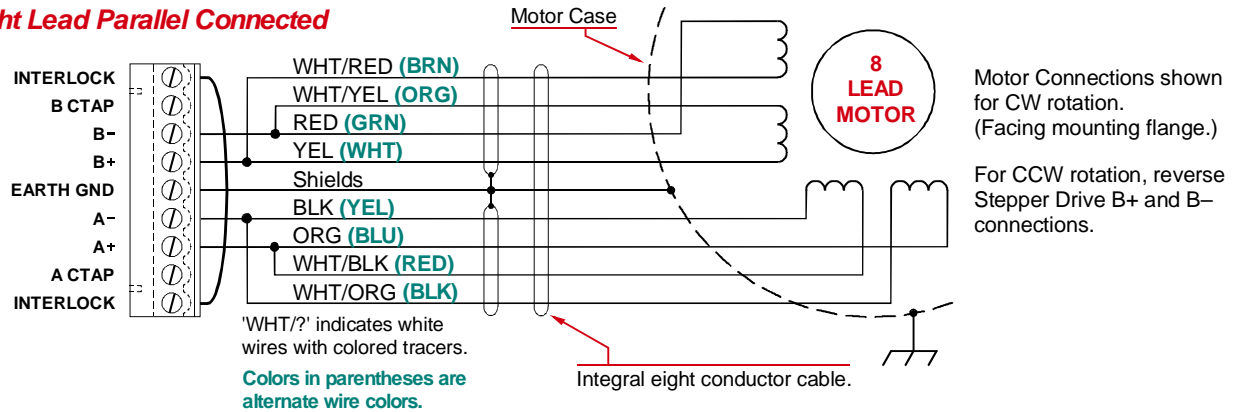

Figure 5.9 Eight Lead Motor Connections



## Step 5: Grounding and Powering the System

**WARNING** The chassis must be connected to earth ground. Failure to properly ground the chassis leaves the potential for severe electrical hazard and/or problems with normal operation.

Properly grounding the SD17063 is accomplished by using the grounding lug. Run a minimum #8 gauge, stranded wire from the drive's grounding lug to your system ground bus. The wire should be as short as possible. Also use an oxide inhibiting joint compound at both connections when installing the wire.

AC power connections are made to the SD17063 using the PC-1 connector kit that ships with the drive. The PC-1 kit includes the power connector and rubber boot. Figure 5.10 below shows how to properly wire and ground the drive.

**NOTE** For clarity, the rubber boot is not shown in the figure. When installing the power cable, slide the rubber boot onto the cable before wiring the connector. When you're sure the wiring is correct, slide the boot over the connector to cover the screw heads.

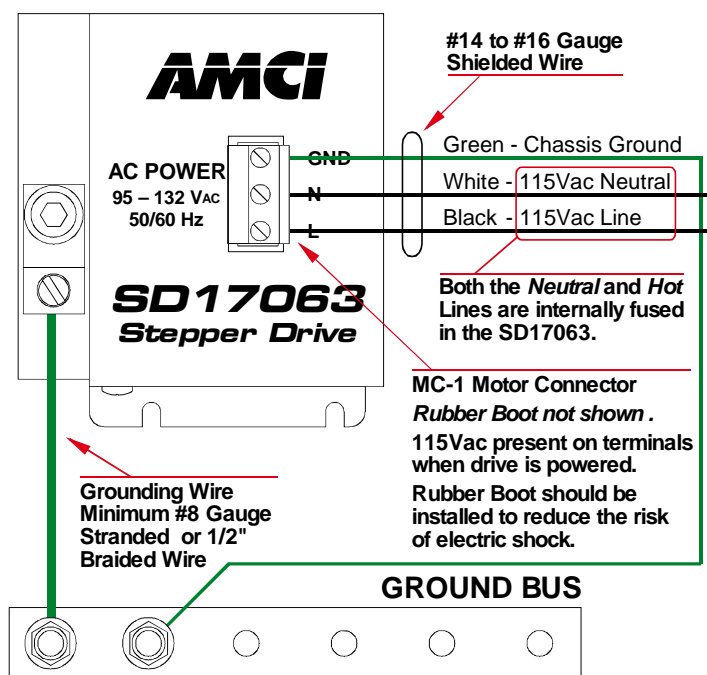

Figure 5.10 Power and Grounding Connections

- WARNINGS**
- 1) Input power must be 95 to 132 Vac, 50/60 HZ, and able to supply 9.5APK for proper operation.
  - 2) Never attempt to power the drive with 230Vac. Doing so will damage the drive and void its warranty. If you are converting from an SD8055 to the SD17063, verify that the SD8055 was operating at 120Vac before applying power to the SD17063. If your installation only has 230 Vac, you must install a step down transformer to power the SD17063. The transformer must be rated for a minimum of 1.1KV<sub>a</sub>.

Both the Neutral and the Line power connections are internally fused in the SD17063. External fuses or circuit breakers can also be used. They must be rated for at least 10 amps.

## Step 6: Testing the System

At this point, the physical installation should be complete. Testing the system includes an initial test to verify wiring, and short procedures to set Current Loop Gain, Output Waveform, and Anti-Resonance settings.

### Initial Test

You may want to uncouple the motor from its load while running the initial test.

- 1) Verify that the rubber boots are in place on the motor and power connectors of the SD17063.
- 2) Apply 120 Vac power to the drive. The Power LED should be on and the other three LED's should be off. If any of these three LED's are on there is a fault. Refer to the **Fault Table** on page 15 for information on the type of fault and its probable causes.
- 3) If there are not faults, have your indexer make a slow move in the counter-clockwise direction for one turn. While the turn is in progress, the STEP LED should blink. Verify that the motor rotated in the correct direction for one complete turn. If you are using an optical encoder or other position feedback, verify that the indexer or controller is reading it properly.
- 4) Repeat step 3 with a move in the clockwise direction. Again verify that the motor rotated in the correct direction for one complete turn.
- 5) If you are using the Disable or Reset Inputs, verify their operation with the motor stopped. Note that the motor will have no holding torque while either of these inputs are active and the motor's shaft will be free to rotate. If you are using the Fault Output, verify that it is *Off* while either of the inputs is active, and *On* when both inputs are off.

If your system fails any of these tests, refer to Appendix C, **TROUBLESHOOTING**, starting on page 54, for suggestions on possible causes for the problems.

When you are finished with the initial test, remember to couple the load and motor if you uncoupled them before the test.

### Determining Current Loop Gain

Current loop gain refers to the gain of the amplifier that controls the current through the motor when the motor's speed is at or below 3 rps. Its default setting of *TYPICAL* is designed to work with motors whose inductance value is above 2.5 mH. You should use the default setting for all AMCI motors except for the SM42 when it is parallel connected to the SD17063. Non-AMCI motors that are series connected should also use the default setting. If you are parallel connecting a non-AMCI motor to the SD17063, then calculate the motor's small signal inductance. If the inductance is greater than 2.5 mH then the default *TYPICAL* setting should work with your motor. If the calculated inductance value is between 1 and 2.5 mH, the default setting will still work, but you may benefit by reducing the current loop gain. Motors with inductances below 1 mH may not work properly with the SD17063.

The procedure for setting the Current Loop Gain is as follows. Note that the *REDUCED 1* setting for the current loop gain has given the best results on the test bench at AMCI for a parallel connected SM42.

- 1) Make sure you have documented the switch setting for your SD17063 because you will change them during this procedure. You can use the **SD17063 Worksheet** found on page 17.
- 2) Remove power from the SD17063
- 3) Set the switches on the SD17063 to the values given in figure 5.11. The Pulse Train Input, Anti-Resonance, Anti-Resonance Phase, Current Control, and Motor Current setting have no effect and should be left at settings you have determined for your system.

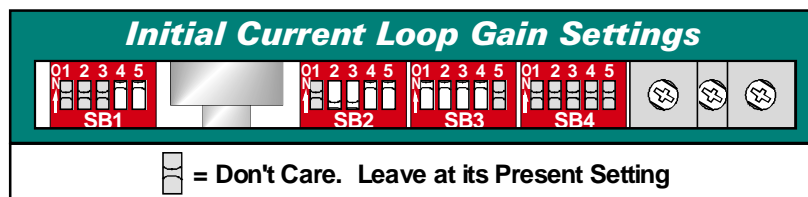

Figure 5.11 Initial Setting of Determining Current Loop Gain

## Step 6: Testing the System (continued)

### Determining Current Loop Gain (continued)

- 4) Apply power to the SD17063. You should hear at least one sound from the motor in the 3 to 5 KHz range that subjectively sounds like AM radio hiss. This is normal. You may also hear a much higher pitched sound in the 10 KHz range. If you do, set the Current Loop Gain setting to *REDUCED 1*. (SB1-4 = 0 and SB1-5 = 1.) This should eliminate the higher pitched sound. If you still hear it, try the *REDUCED 2* and *3* settings. The first setting that eliminates the higher pitched sound is the setting you should use. If you do not hear any changes to the sounds from the motor when testing the different settings, then use the *TYPICAL* setting.
- 5) After documenting your Current Loop Gain setting, restore all other settings to the values you documented at the beginning of this procedure.

A low inductance stepper motor can have an excessive amount of overshoot and ringing at the start or end of a move. Adjusting the Current Loop Gain dampens the amount of overshoot and ringing. That is why we instruct you to use the lowest *REDUCED* setting that eliminates the high pitched sound. Using a higher setting will overdampen the system. The system will still work when using a higher setting, and nothing will be harmed, but the motor will take slightly longer to reach its target position.

### Determining Anti-Resonance Setting

Anti-Resonance is set by trial and error. The setting that gives you the best performance is the setting to use. Because the load on the motor affects the resonance points, the final settings cannot be determined until the machine is operational.

The Anti-Resonance feature affects motor performance when the motor's speed is between 3 and 20 rps. All stepper motors experience resonance problems where they run "rough" at certain speeds. At these speeds, the motor cannot run at the commanded velocity and its true velocity oscillates around the commanded value. The Anti-Resonance feature monitors the current feedback from the motor to detect when resonance occurs and modifies the current waveforms to compensate. A vast majority of systems will work best with the Anti-Resonance feature *Enabled*, (SB1-2=0, which it is by default), and the Anti-Resonance Phase feature set to *Normal Inertial Load*, (SB1-3=0, also the default). These settings should be used unless your machine is experiencing resonance problems. Resonance problems are typically rough operation and increased audible noise at specific speeds.

If you are experiencing resonance problems with the Anti-Resonance and Anti-Resonance Phase settings at their defaults, try setting the Anti-Resonance Phase to its *Low Inertia Setting*, (SB1-3=1). This setting has its greatest effect when the inertia of your load is less than the inertia of your motor, or you have a very high torque-to-inertia ratio. Values for the inertia of AMCI Motors can be found in Table 2.5, *Stepper Motor Specifications* found on page 16.

Finally, the resonance of some mechanical loads can interfere with the Anti-Resonance feature. When this occurs, the Anti-Resonance feature tries to compensate at the wrong speeds and actually makes operation worse. In these rare instances, you should disable the Anti-Resonance feature, (SB1-2=1). If your system runs better with the Anti-Resonance feature totally disabled, then this is the setting you should use.

### Determining Output Waveform Setting

**NOTE**  When full stepping the motor, (200 Step/Rev), you must leave the Output Waveform setting to *Pure Sine*. Using any other setting will put the SD17063 in Self-Test mode.

Like Anti-Resonance, the Output Waveform setting is determined by trial and error. The setting that gives you the best performance is the setting to use. However, if you do not see any performance gains when using the reduced waveforms, use the *Pure Sine* setting because the motor runs most efficiently with this setting.

When trying the different Output Waveform settings watch for smoother operation. If you are using the stepper motor to finely position a load, also look for an improvement in positional accuracy. the setting that yields the smoothest operation and/or best positional accuracy is the setting to use. You will not harm the motor or drive if you reduce the current waveform too much while testing the system.

***Notes***

# APPENDIX A

## CHOOSING YOUR MOTOR

### Sizing Your Motor

Your motor choice is based on the output torque you need, the mounting space you have, and your budgetary constraints. Torque curves for all of AMCI's motors are available on the following pages. There are a few things to remember when choosing your motor based on torque curves.

- 1) The torque curves in this manual are for the SD17063. You cannot use these curves to accurately determine the amount of torque from an AMCI motor when it is attached to a different drive. Nor can you accurately determine the amount of torque from a motor when attached to an SD17063 if its torque curves were generated using a different drive. In general, if a drive's output bus is lower than 170 Vdc, then the available torque will drop off faster as speed increases when compared to the SD17063.
- 2) Torque curves are shown with 200 steps/turn (full step) resolution selected. Higher resolution (half step or micro-stepping) result in a  $\pm 10\%$  deviation in the torque curves.
- 3) Make sure that the motor can provide the needed torque over the entire speed range of your application. Available torque drops as speed increases, so evaluate the motor's torque at its highest operating speed.
- 4) As you can see from the torque curves, attaching a motor's windings to the drive in parallel has the advantage of more torque from the motor at high speeds when compared to attaching the windings in series. The disadvantage is that the motor will *always* run hotter when connected in parallel so additional cooling may be needed.

A simple guideline is to use the largest motor your mounting space and budgetary constraints allow. Because the  $I^2R$  losses in the motor's windings manifest themselves as heat, the maximum allowable motor temperature limits the motor's current. Using the largest motor possible may allow you to use a lower current setting on the SD17063 drive. This lowers the  $I^2R$  losses, and the operating temperature of the motor, which increases the motor's life.

### Determining Your Motor Current Setting

Your motor current setting is based on the amount of torque needed from the motor. In many cases, the amount of torque that you need will also determine how you attach the motor to the SD17063. Connecting the motor windings in parallel will give you more torque at higher speeds.

For the SM34-650 and SM42-1250, connecting the motor in series will give you more torque at low speeds. This is because the limiting factor on the motor current for these two motors is the SD17063 drive, not the motor. For the SM34-650D, connecting the motor in series will give you more torque for speeds below 420 RPM. (See figure A.6, [SM34-650 Torque Curves](#) on page 47.) For the SM42-1250, series connecting the motor will give you more torque for speeds below 720 RPM (See figure A.7, [SM42-1250 Torque Curves](#) on page 47).

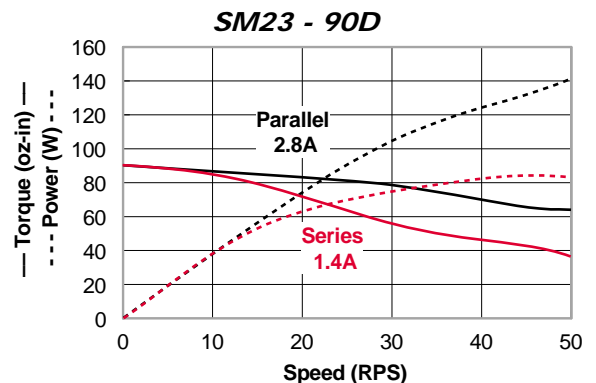

Figure A.1 SM23-90 Torque Curves

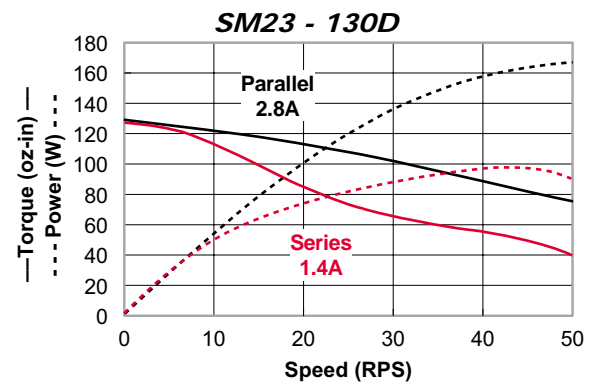

Figure A.2 SM23-130 Torque Curves

## Determining Your Motor Current Setting (continued)

Torque curves show the performance of the motor at the stated current, which is the maximum setting for the motor or the drive, whichever is less. If you decide to use a lower current setting than the value listed in the curve, be aware that a reduction in current proportionally reduces the holding torque. However, a reduction in current may not lead to a proportionally reduction in torque at high speeds, especially if the motor is series connected. At high speeds, motor torque is limited by the voltage bus of the drive and the inductance of the motor. (The simplest explanation is that the drive does not have enough time to establish the full current through the motor before it must switch the current to the winding.)

Because of this, its difficult to calculate the exact amount of high speed torque a motor will give you when you reduce its current setting. Its often easier to determine your optimum current setting by testing your machine at various current settings and then deciding which setting gives you the best performance.

### A Note on Microstepping

Many microstepping drives control the *peak* current through the motor. At low speeds, this type of current control drops the available torque of a microstepped motor to approximately 70.7% of that available when the motor is full stepped.

However, by default, the SD17063 controls the *RMS* current through the motor. Therefore, the current supplied by the SD17063 when microstepping is always the *power* equivalent of the full step current. This means that the motors' full torque is always available. RMS current is maintained down to 0.005 revolutions per second. Below this speed, the SD17063 automatically switches to peak current control to prevent motor damage. If you decide to use microstepping, AMCI suggests using RMS control.

If you are full stepping the motor, or you are using the SD17063 to replace a drive that used peak current control, then you can configure the SD17063 to use peak current control by changing a DIP switch on the top of the drive.

### Unipolar Ratings

By convention, most motor specifications, including maximum motor current, are based on a *unipolar* motor connection. The first stepper drives were called *Unipolar Drives* because of the way they controlled the rotational direction of the motor. A typical stepper motor has four windings. A Unipolar Drive uses two of these windings to drive the motor clockwise, and the other two windings to drive the motor counter-clockwise. Therefore, two of the windings in the motor are always off, which means the available torque is less than if you could use all four windings together. A *Bipolar Drive*, such as the SD17063, has the additional electronics that allow it to switch the direction of current flow through its output drivers. Therefore a Bipolar Drive can use all four windings at the same time, thereby increasing the available torque from a motor.

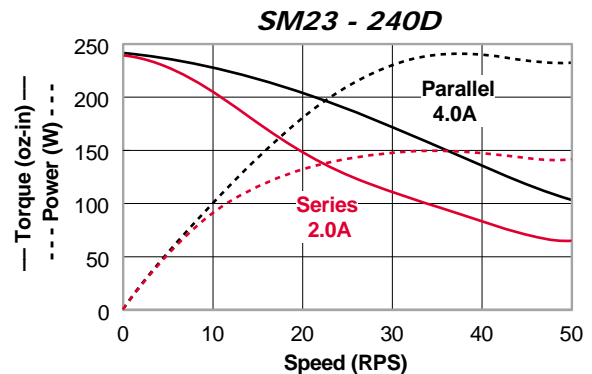

Figure A.3 SM23-240 Torque Curves

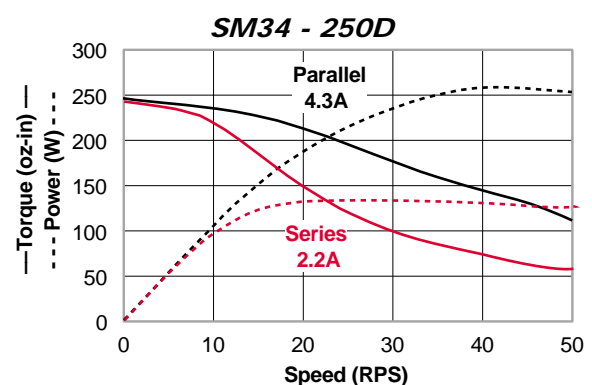

Figure A.4 SM34-250 Torque Curves

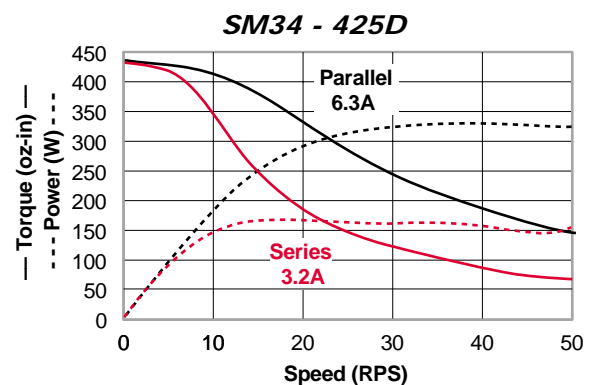

Figure A.5 SM34-425 Torque Curves



## Unipolar Ratings (continued)

Many motor manufactures still publish unipolar ratings for their motors instead of bipolar ratings. Therefore, you must convert the unipolar current rating to either the bipolar series or bipolar parallel current rating to determine the correct setting for the SD17063. Table A.1 lists the multipliers to convert from unipolar to either of the bipolar values. Conversion factors for voltage, winding resistance, winding inductance, and holding torque are also given.

As a conversion example, assume a size 34, two stack motor has a unipolar current rating of 3.7 amps and you will be wiring the motor to the SD17063 in parallel. The conversion from the Unipolar to Bipolar Parallel is 1.41. Therefore the maximum current setting for this motor is  $3.7 * 1.41 = 5.2$  amps.

In order to avoid confusion, AMCI publishes the bipolar series and bipolar current ratings on all of our motors. For your convenience, Table 2.5, *Stepper Motor Specifications* on page 16 lists the maximum series and parallel currents for our motors.

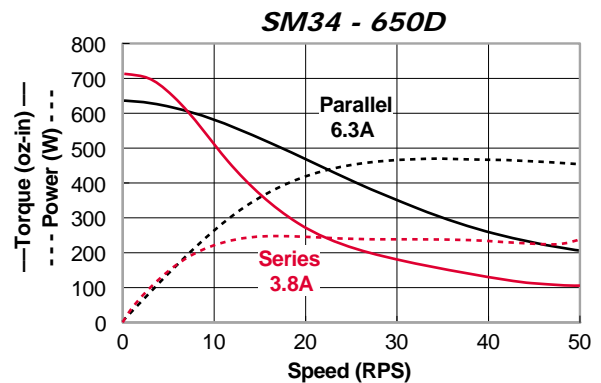

Figure A.6 SM34-650 Torque Curves

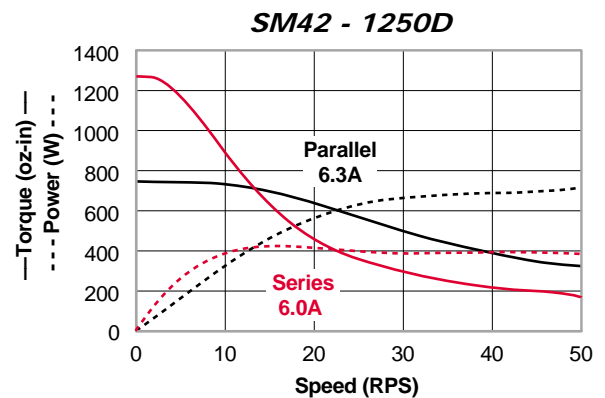

Figure A.7 SM42-1250 Torque Curves

		Rating	Desired Value		
			Unipolar Multiplier	Bipolar Series Multiplier	Bipolar Parallel Multiplier
Known Value	Unipolar or Bipolar Center Tap <sup>1</sup>	Volts	1	1.41	0.707
		Amps	1	0.707	1.41
		Ohms	1	2	0.5
		Inductance	1	4	1
		Holding Torque	1	1.41	1.41
	Bipolar Series	Volts	0.707	1	0.5
		Amps	1.41	1	2
		Ohms	0.5	1	0.25
		Inductance	0.25	1	0.25
		Holding Torque	0.707	1	1
	Bipolar Parallel	Volts	1.41	2	1
		Amps	0.707	0.5	1
		Ohms	2	4	1
		Inductance	1	4	1
		Holding Torque	0.707	1	1

1) "Bipolar Center Tap" refers to six lead motors that are connected to the drive from center tap to one end. In this configuration, only half or the winding is used. If the current specification of the motor is listed as bipolar, and you decide to connect the motor from center tap to end, use the Bipolar Series to Unipolar multipliers.

Table A.1 Motor Conversion Factors



*Notes*

## UPGRADING TO THE SD17063 REV. B

This appendix gives information on upgrading from an AMCI SD8055 or older revision SD17063 to the SD17063 rev. B. This information is valuable if you are replacing one of these units or are upgrading the design of your system. Information on setting the switches of an SD17063 rev. B to mimic the older units is given as well as information on wiring and operation changes.

### Replacing a SD8055

The SD8055 is an older AMCI stepper drive that has been phased out and replaced by the SD17063 rev. B. The SD8055 is still supported by AMCI but it is no longer sold as a new unit. The SD17063 rev. B has several advantages over the SD8055. Because of its higher bus voltage and output current, the SD17063 rev. B can generate more torque from a motor and the drive's features give you better control over motor operation.

#### **NOTE**

Before replacing the SD8055, verify that the motor's insulation is rated for the SD17063. Minimum phase-to-phase and phase-to-ground voltage rating is 500Vdc. All AMCI motors meet this specification.

### DIP Switch Settings

- **Pulse Train Input, SB1-1:** Set to Pulse /Direction (SB1-1 = 1)
- **Anti-Resonance Enable, SB1-2:** Feature not available on SD8055. Set to Enable (SB1-2=0)
- **Anti-Resonance Phase, SB1-3:** Feature not available on SD8055. Set to Normal (SB1-3=0)
- **Current Loop Gain, SB1-4/5:** Feature not available on SD8055. Set to Typical. (SB1-4&5 = 0)
- **Current Control, SB2-1:** The SD8055 drive was designed to control the peak current through the motor. For complete compatibility, set SB2-1=1, which selects Peak current control on the SD17063. However, if you are micro-stepping your motor, AMCI strongly suggests using RMS current control (SB2-1=0) because this will give you more torque.
- **Idle Current Reduction, SB2-2/3:** There is a "50% IDLE" switch on the SD8055. If this switch is pushed toward the "50% IDLE" label on the SD8055, then set the SD17063 to it *To 50%* setting. (SB2-2=0, SB2-3=1) If the DIP switch is pushed away from the label, then set the SD17063 to *Not Reduced*. (SB2-2 and SB2-3 = 1) If your system does not require holding torque, then consider eliminating the current when the motor is idle. (SB2-2 and SB2-3 = 0) This will significantly reduce motor heating.
- **Output Waveform, SB2-4/5:** Feature not available on SD8055. Set to Pure Sine (SB2-4&5=0)
- **Step Resolution, SB3-1/2/3/4:** There are four "MICROSTEP RESOLUTION" switches numbered 1 through 4 on the SD8055. They correspond directly to the switches on the SD17063. Switch 1 corresponds to SB3-1, switch 2 to SB3-2, switch 3 to SB3-3 and switch 4 to SB3-4. On the SD8055, having a switch pushed toward the number on the switch corresponds to a "0" on the SD17063. Having it pushed away from the number on the switch corresponds to a "1" on the SD17063.
- **Motor Current, SB3-5 & SB4:** There are six "DRIVE CURRENT" switches on the SD8055. If you have the manual for the SD8055, it is easier to look up the value the switches are set for and look up the switch setting for the SD17063 on the worksheet. If you don't have the manual, use this procedure:
  - 1) Sum up all of the values that have a switch pushed toward its label. Example: The 0.8 and 1.9 switches are the only two pushed towards their labels. The sum is  $0.8 + 1.9 = 2.7$ .
  - 2) Add 0.5 to the sum found in step 1. This is the current setting for the SD17063. To finish the example,  $2.7 + 0.5 = 3.2$  amps.

## Replacing a SD8055 (continued)

### Indexer Connector Wiring Changes

- **± Step and ± Direction:** Can be brought over directly to the SD17063.
- **± Enable Input:** Can be brought over to the SD17063's ± Disable Input. Any current limiting resistors used because the input voltage exceeds 5 Vdc must be replaced. 12 to 15 Vdc systems that used a 1KΩ resistor with the SD8055 must replace them with 2 KΩ resistors. 24 Vdc systems need to replace the 2 KΩ resistor with a 3.9 KΩ resistor.
- **± Fault Output:** Can be brought over directly to the SD17063, but you will probably want to reverse its logic.

#### **NOTE**

The logic of the fault outputs is reversed between the SD8055 and the SD17063. The Fault Output of the SD8055 is normally *off*, and turns on when there is a fault, while the Fault Output of the SD17063 is normally *on* and turns off when a fault occurs.

The simplest solution depends on your application. If you are using the fault output as an open collector sinking output with a pull up resistor, it may be relatively simple to change the wiring to an open collector sourcing output with a pull down resistor. Another option is to change the instructions in your ladder logic that monitor for faults if you are using a PLC to monitor the output.

### Motor Connector Wiring Changes

- **Interlock Pins:** Not available on the SD8055. Must be connected with a short jumper on the SD17063 for normal operation.
- **CTap Pins:** Not available on the SD8055. You do not need to make connections to these pins for normal operation. These pins are electrically isolated from the drive and are for wiring convenience only. These pins are used with six lead motors and also with eight lead motors wired in series. Check your wiring diagrams to see if you can use these pins. Wiring diagrams for six and eight lead motors can be found in the manual section [Step 4: Connecting the Motor](#) on pages 39 and 40.
- **± A Phase:** Can be brought over directly to the SD17063.
- **± B Phase:** **WIRING MUST BE REVERSED!** The wires in the -B terminal of the SD8055 go to the +B terminal of the SD17063 and the wires in the +B terminal of the SD8055 go to the -B terminal of the SD17063.

#### **WARNING**

If the ±B phase wiring is not reversed, the motors rotation will reverse. (Commanding it to rotate clockwise will rotate it counter-clockwise and a counter-clockwise command will result in a clockwise rotation. Failure to observe this warning can result in undesired operation with possible damage to equipment or injury to personnel.

- **Earth GND (Shields):** Not used on the SD8055. The shields of the motor cable must be connected to the terminal for normal operation.

### Power Connector Wiring Changes

#### **WARNINGS**

- 1) Input power must be 95 to 132 Vac, 50/60 HZ, and able to supply 9.5APK for proper operation.
- 2) Never attempt to power the drive with 230Vac. Doing so will damage the drive and void its warranty. If you are converting from an SD8055 to the SD17063, verify that the SD8055 was operating at 120Vac before applying power to the SD17063. If your installation only has 230 Vac, you must install a step down transformer to power the SD17063. The transformer must be rated for a minimum of 1.1KV<sub>a</sub>.

## ***Replacing a SD8055 (continued)***

### **Grounding Lug Connection**

A grounding wire from the SD17063's grounding lug to your system's ground bus must be installed. See figure 5.10, *Power and Grounding Connections* on page 41 for more information.

### **Improving Upon a SD8055 Installation**

The primary advantages of using an SD17063 instead of an SD8055 are:

- Higher torque from the same motor
- No loss in torque when microstepping the motor due to the SD17063's RMS current control
- Smoother operation due to Anti-Resonance, Current Loop Gain, and Output Waveform features.

When you were converting switch settings from the SD8055 to the SD17063 you had the choice of setting the Current Control feature of the SD17063 to *RMS* or *Peak*. (SB2-1) The SD8055 uses peak current control only, so you may have set the Current Control feature to Peak, (SB2-1=1), to match the SD8055. If you are full stepping the motor, this setting actually has no effect. If you are micro-stepping the motor, including half-stepping, consider using the RMS control instead. (SB2-1=0) When micro-stepping the motor and using Peak current control, available low speed torque is 70% of that available when using RMS current control.

After your installation is complete, you should test the system using the procedures given in *Step 6: Testing the System*, starting on page 42. Note that you may see a significant increase in high speed torque when using the SD17063. This additional torque may be helpful, or even needed, for your application. Also consider reducing the motor current until the torque levels are equivalent to the SD8055's. The reduction in motor current will decrease the motor's temperature which will prolong its life.

## Replacing an Older SD17063

The older SD17063 stepper drive has also been phased out and replaced by the SD17063 rev. B. The older SD17036 is still supported by AMCI but it is no longer sold as a new unit. The SD17063 rev. B has several additional features but the two drives are basically the same. The new Current Loop Gain feature, and improvements to the Idle Current and Anti-Resonance features, are the primary enhancements to the SD17063 rev. B drive.

### DIP Switch Settings

The older SD17063's have only three switch blocks, labeled SB1 through SB3 while the SD17063 rev. B has four blocks. Settings from the older SD17063 can be directly transferred to the newer drive by using the table below. (If the older drive has a switch is on, the SD17063 rev. B should also have it on.) The table contains four columns. The first is the name of the feature, the second is the switch used by the older SD17063 and the third is the switch used by the SD17063 rev. B. The fourth column is for comments.

Feature	Old SD17063 Switch	SD17063 rev. B Switch	Comments
Anti-Resonance Enable	SB1-1	SB1-2	
Anti-Resonance Phase		SB1-3 = 0	May change setting while testing the system.
Idle Current Reduction	SB1-2	SB2-2 = SB1-2 SB2-3 = 1	SB2-2 on Rev. B drive is set the same as switch SB1-2 on older drive. SB2-3 = 1. This sets Idle Current Reduction to <i>Not Reduced</i> or <i>To 50%</i> .
Pulse Train Input	SB1-3	SB1-1	
Output Waveform	SB1-4/5	SB2-4/5	
Step Resolution	SB2-1/2/3/4	SB3-1/2/3/4	
Motor Current	SB2-5 & SB3	SB3-5 & SB4	
Current Loop Gain		SB1-4/5 = 0	May change setting while testing the system.
Current Control		SB2-1 = 0	Sets drive for <i>RMS</i> current control.

Table B.1 SD17063 Switch Setting Conversion

### Indexer Connector Wiring

The Indexer Connector can be plugged directly into the SD17063 rev. B without wiring changes.

### Motor Connector Wiring

The Motor Connector can be plugged directly into the SD17063 rev. B without wiring changes.

### Power Connector Wiring Changes

The grounding wire from the drives Grounding Lug *must* be installed on the SD17063 rev. B. The IEC connector on the old SD17063 must be cut off, the wires stripped and installed in the supplied power connector. See figure 5.10, *Power and Grounding Connections* on page 41 for more information.

### Improving Upon an Older SD17063 Installation

Improvements in your system may result from setting the Current Loop Gain and Anti-Resonance Phase features on the SD17063 rev. B, which is done during the systems initial test. If your system does not require holding torque from the motor, consider changing the Idle Current Reduction setting to eliminate motor current when the motor is idle. The To 0% setting is chosen when SB2-2 and SB2-3 both equal zero.

After your installation is complete, you should test the system using the procedures given in *Step 6: Testing the System*, starting on page 42.



# APPENDIX C

## TROUBLESHOOTING

### Self Test Mode

The Self Test can be used to familiarize yourself with the drive or test the SD17063 and motor hookup without an indexer. To run the Self Test on a bench, use the following instructions:

- 1) Indexer connections are not necessary. If you have a 5 to 24 Vdc power supply, you can wire switches to the  $\pm$ Disable and  $\pm$ Reset inputs. See figure 5.4, *Single Ended Input Connections*, on page 35. If your supply is greater than 5 Vdc, you must use the current limiting resistors given in the figure.
- 2) Referring to the *SD17063 Worksheet* on page 17, set the motor current to an appropriate value for your motor. SM23's can have their current set to 1.0 amp, SM34's to 2.0 amps, and SM42's to 3.0 amps. If you have already determined the current setting for your application, you can use that value.
- 3) Still using the worksheet, set the Output Waveform switches to -4%, (SB2-4 = 0, SB2-5 = 1). Set the Resolution switches to 200 Steps per Turn, (SB3-1/2/3/4 = 0). Set the Anti-Resonance switch to Disabled.
- 4) Slide the rubber boot onto your motor's wires and wire the motor to the Motor Connector. If you've already determined how the motor will be wired, then connect it that way. If you haven't determined how the motor will be wired, then wire four and eight lead motors in parallel and use the Center Tap connection for six lead motors. Cover the connector with the rubber boot and insert the connector into the drive.
- 5) Slide the rubber boot over your power cord, and wire it to the connector. Slide the boot onto the connector and insert it into the drive. If bench testing, you will have to supply your own power cord. Verify all connections before applying power.



#### WARNING

You must use a 3-prong grounded outlet when applying power to the SD17063. The drive may pose a serious shock hazard if not properly grounded.

- ▶ When you apply power to the drive the motor should start turning counter-clockwise, (looking at the shaft), at a speed of 1 RPM. If the motor rotates clockwise, remove power from the drive and reverse the  $\pm$ B motor connections. At this point the **POWER** LED should be on and the **STEP** LED should be blinking.
- ▶ If you have wired the  $\pm$ Disable input, apply power to it. The motor will stop rotating, and it will have no holding torque, while the input is active. The **STEP** LED will also turn off. When power is removed from the input, the motor will start turning and the **STEP** LED will blink again.
- ▶ If you have wired the  $\pm$ Reset input, apply power to it. The motor will stop turning and will have no holding torque. The **STEP** LED will also turn off. While power is applied to the  $\pm$ Reset input, change the Output Waveform switches to select *Pure Sine*. (SB2-4 and SB2-5 = 0.) When power is removed from the  $\pm$ Reset input, the motor will not turn because the SD17063 is no longer in Self Test mode.

If the drive and motor do not work as expected, then a problem exists with your setup, the motor, or the drive. Refer to the troubleshooting tables on the following page for information on problems and possible causes. If you cannot resolve the problem with the troubleshooting tables, call AMCI technical support for assistance.

### Troubleshooting Tables

The following tables list problem symptoms and possible solutions. The tables break the problem symptoms into categories to make it easier to search for your specific problem. Cross-references into the manual are sometimes given that leads to additional information.

#### Indicator LED's

Symptom	Solution
The <b>OVERTEMP</b> LED is blinking but the system seems to be working fine.	A Velocity Step Violation has occurred. The frequency of the directional pulses from the indexer exceeded 2 MHz. This fault may be caused by noise on one or both of the directional inputs. The <b>OVERTEMP</b> LED will continue to blink until the drive is reset or power is cycled. See <i>Detectable Faults and Errors</i> on page 14 for more information.
The <b>MOTOR FAULT</b> LED is blinking but the system seems to be working fine.	A Window Step Violation has occurred. The indexer sent pulses to the SD17063 while the Disable Input was active or before the 275 millisecond current 'ramp-up' period expired after The Disable Input was released. The <b>MOTOR FAULT</b> LED will continue to blink until the drive is reset or power is cycled. See <i>Detectable Faults and Errors</i> on page 14 for more information.
All LED's are off and the Fault Output is active. Power is applied to the drive.	The AC line voltage may be too low. It must be greater than 85Vac for the SD17063 to operate.
The <b>POWER</b> LED is the only LED on, but the Fault Output is active and the motor is not powered.	The $\pm$ Disable or $\pm$ Reset input may be active. If either of these inputs are receiving power, the Fault output is active and motor current is disabled.
The <b>OVERTEMP</b> LED is on.	The SD17063 has overheated. The drive turns off motor current when the heatsink temperature passes 95°C (200°F). Remove power from the SD17063 and allow it to cool. If this problem occurs frequently, you may need to install a small cooling fan below the drive to force air up through it.
The <b>MOTOR FAULT</b> LED is on.	<ol style="list-style-type: none"> <li>1) The jumper across the <b>INTERLINK</b> pins of the Motor Connector is missing.</li> <li>2) There is a short between the motor's phases or one of the phases and ground. Remove the Motor Connector from the SD17063 and use a ohmmeter to check for shorts between A phase and B phase. Verify that the motor cable shield is connected to the motor frame and then check for shorts from A and B phases to shields.</li> </ol>
The <b>POWER</b> LED is blinking.	<p>An Output Bus Overvoltage fault has occurred. Voltage on the motor pins has exceeded 250Vdc. Cycle power to the drive or pulse the Reset input to clear the fault.</p> <p>When the motor is stopped quickly, it produces an inductive voltage spike that is usually handled by the SD17063's internal regeneration resistor. This fault occurs when the power is too great for the resistor to dissipate. You should increase your deceleration time to limit the power generated by the motor.</p> <p>If this fault occurs repeatedly, the regeneration resistor may be damaged and the SD17063 may need to be returned for repair.</p>

Table C.1 Indicator LED Problem Table



**Troubleshooting Tables (continued)**

**Motor Problems**

Symptom	Solution
The motor has no holding torque.	<ol style="list-style-type: none"> <li>1) If any of the Indicator LED's are on, other than the POWER LED, refer to the <i>Indicator LED's</i> table on the preceding page.</li> <li>2) If the motor rotates when commanded but has no holding torque, then your Idle Current Reduction switches are set to the <i>To 0%</i> setting which removes motor current when the drive is idle for more than one second. See figure 3.3, <i>Motor Switch Settings</i> on page 19 for information on setting the Idle Current Reduction switches.</li> <li>3) The SD17063 ships with all switches set to zero. If the Motor Current switches (SB3-5 and SB4) are left at zero, the Motor Current equals zero amps. See figures 3.6 through 3.8, <i>Motor Current Settings</i> starting on page 24 for the Motor Current settings.</li> </ol>
The motor is running faster/slower than expected and/or the distance traveled is father/shorter than expected.	Most likely a problem with the SD17063's Step Resolution setting or the indexer's programming. If the motor is running too fast, either the Step Resolution on the SD17063 (SB3-1/2/3/4) is set too low, or the indexer programmer assumed a higher step resolution than the drive is set for when determining the total number of pulses to apply to the motor. If the motor is running slow, the Step Resolution is set too high or the indexer programmer assumed a lower step resolution.
The SD17063 and motor work fine in Self Test mode, but the motor does not run when pulses are applied from the indexer.	<ol style="list-style-type: none"> <li>1) The acceleration values may have been set too high when the indexer was programmed. The motor may start to accelerate and stall as the acceleration increases.</li> <li>2) The Step Resolution may be set too low. (See previous problem.) This will have the same effect as setting the acceleration to high.</li> </ol>
The motor only runs in one direction.	This problem is usually caused by the directional pulse inputs. If your indexer is sending pulses in the CW/CCW format and the drive is configured for the Step/Dir format, the motor will rotate counter-clockwise when sending CW pulses, and will not rotate at all when sending CCW pulses. If the indexer is sending pulses in the Step/Dir format and the drive is configured for the CW/CCW format, the motor will only rotate clockwise, even when the indexer is commanding a counter-clockwise move.
The motor runs backwards. (CW instead of CCW and/or CCW instead of CW)	<ol style="list-style-type: none"> <li>1) One of the motor phases may be reversed. This is most commonly the problem with converting from a SD8055 to a SD17063 because the sense of the <math>\pm B</math> phase is reversed between the two drives.</li> <li>2) There may be a problem with the directional inputs. Either they are wired incorrectly or the format is wrong. Check wiring and see the previous problem for more information on problems with format.</li> </ol>

**Indexer Problems**

Symptom	Solution
My indexer/PLC reports a fault from the SD17063 when everything seems fine.	Your logic maybe reversed. On the SD17063, the Fault Output is on (conducts current) when the drive is working correctly and turns off (stops current flow) when there is a fault with the drive. Therefore, losing power to the drive appears as a fault. If you're expecting the fault output to turn on and conduct current when there is a fault, then your logic is reversed. This problem is most common when converting from a SD8055 to a SD17063 because the fault logic between the two is reversed. The fault output on the SD8055 does turn on when there is a fault, not off as it does with the SD17063.



***ADVANCED MICRO CONTROLS INC.***

20 GEAR DRIVE, TERRYVILLE, CT 06786 T: (860) 585-1254 F: (860) 584-1973

[www.amci.com](http://www.amci.com)

**LEADERS IN ADVANCED CONTROL PRODUCTS**