

Overview

The AMCI Nexus LDT Interface module connects a LDT sensor to a network. The available networks, along with the corresponding AMCI part number are shown in the following table.

Network	LDT Interface Part Number	Multiple Magnet LDT Interface Part Number
ControlNet	NX2C4C	NX2C4C-08
DeviceNet	NX2C4D	Not Available
Ethernet	NX2C4E	NX2C4E-08
Profibus	NX2C4P	Not Available
Modbus TCP/IP	NX2C4T	NX2C4T-08

The NX2C4X uses twenty-eight 16 bit input words and thirty-three 16 bit output words to communicate with the network.

The NX2C4X-08 multiple magnet version uses 136 16 bit input words and thirty three 16 bit output words to communicate with the network.

Note: Because DeviceNet and Profibus do not support the transfer of 136 words; these versions of the Multiple Magnet LDT Interface Nexus are not available.

Sample programs for this and other AMCI products are available from the following page of our website.

<http://www.amci.com/sampleprograms.asp>

Table of Contents

General Information		3
Installation	Chapter 1	4
	Hardware Overview	4
	Sensor Connector & Wiring	5
	LED Function	6
	Module Specifications	6
	Mounting	8
Programmable Parameters	Chapter 2	11
	Count Direction	11
	Transducer Fault Latch	11
	Velocity Update Time	11
	LDT Mode	11
	Number of Recirculations	11
	LED Enable	11
	LDT Gradient	12
	Full Scale Count	12
	Full Scale Length	12
	Preset Value	12
	Apply Preset	12
	EEPROM Use Warning	12
NX2C4X Input & Output Registers	Chapter 3	13
	Input Words	13
	Status Bits	14
	Output Words	15
	Control Word	16
	Configuration Word	16
NX2C4X-08 Input & Output Registers	Chapter 4	17
	Input Words	17
	Status Bits	18
	Output Words	19
	Control Word	20
	Configuration Word	20
General Programming Notes and Programming Sequence	Chapter 5	21
Network Configurations	Chapter 6	22
	NX2C4C ControlNet	22
	NX2C4D DeviceNet	25
	NX2C4E Ethernet IP	28
	NX2C4P Profibus	30
	NX2C4T Modbus TCP/IP	33
Manual Revision History	Chapter 6	37

General Information

Important User Information

The products and application data described in this manual are useful in a variety of different applications. Therefore, the user and others responsible for applying these products described herein are responsible for determining the acceptability for each application. While efforts have been made to provide accurate information within this manual, AMCI assumes no responsibility for the application or the completeness of the information contained herein. Throughout this manual the following two notices are used to highlight important points.

WARNINGS tell you when people may be hurt or equipment may be damaged if the procedure is not followed properly.

CAUTIONS tell you when equipment may be damaged if the procedure is not followed properly. No patent liability is assumed by AMCI, with respect to use of information, circuits, equipment, or software described in this manual. The information contained within this manual is subject to change without notice. UNDER NO CIRCUMSTANCES WILL ADVANCED MICRO CONTROLS, INC. BE RESPONSIBLE OR LIABLE FOR ANY DAMAGES OR LOSSES, INCLUDING INDIRECT OR CONSEQUENTIAL DAMAGES OR LOSSES, ARISING FROM THE USE OF ANY INFORMATION CONTAINED WITHIN THIS MANUAL, OR THE USE OF ANY PRODUCTS OR SERVICES REFERENCED HEREIN.

Standard Warranty

ADVANCED MICRO CONTROLS, INC. warrants that all equipment manufactured by it will be free from defects, under normal use, in materials and workmanship for a period of [18] months. Within this warranty period, AMCI shall, at its option, repair or replace, free of charge, any equipment covered by this warranty which is returned, shipping charges prepaid, within 18 months from date of invoice, and which upon examination proves to be defective in material or workmanship and not caused by accident, misuse, neglect, alteration, improper installation or improper testing. The provisions of the "STANDARD WARRANTY" are the sole obligations of AMCI and excludes all other warranties expressed or implied. In no event shall AMCI be liable for incidental or consequential damages or for delay in performance of this warranty.

Returns Policy

All equipment being returned to AMCI for repair or replacement, regardless of warranty status, must have a Return Merchandise Authorization number issued by AMCI. Call (860) 585-1254 with the model and serial numbers along with a description of the problem. A "RMA" number will be issued. Equipment must be shipped to AMCI with transportation charges prepaid. Title and risk of loss or damage remains with the customer until shipment is received by AMCI.

24 Hour Technical Support Number

Technical Support, in the form of documents, FAQs, and sample programs, is available from our website, www.amci.com. 24 Hour technical support is also available on this product. For technical support, call (860) 585-1254. Your call will be answered by the factory during regular business hours, Monday through Friday, 8AM - 5PM EST. During non-business hours, an automated system will ask you to leave a detailed message and the telephone number that you can be reached at. The system will page an engineer on call. Please have your product model number and a description of the problem ready before you call.

Chapter 1: Hardware Overview

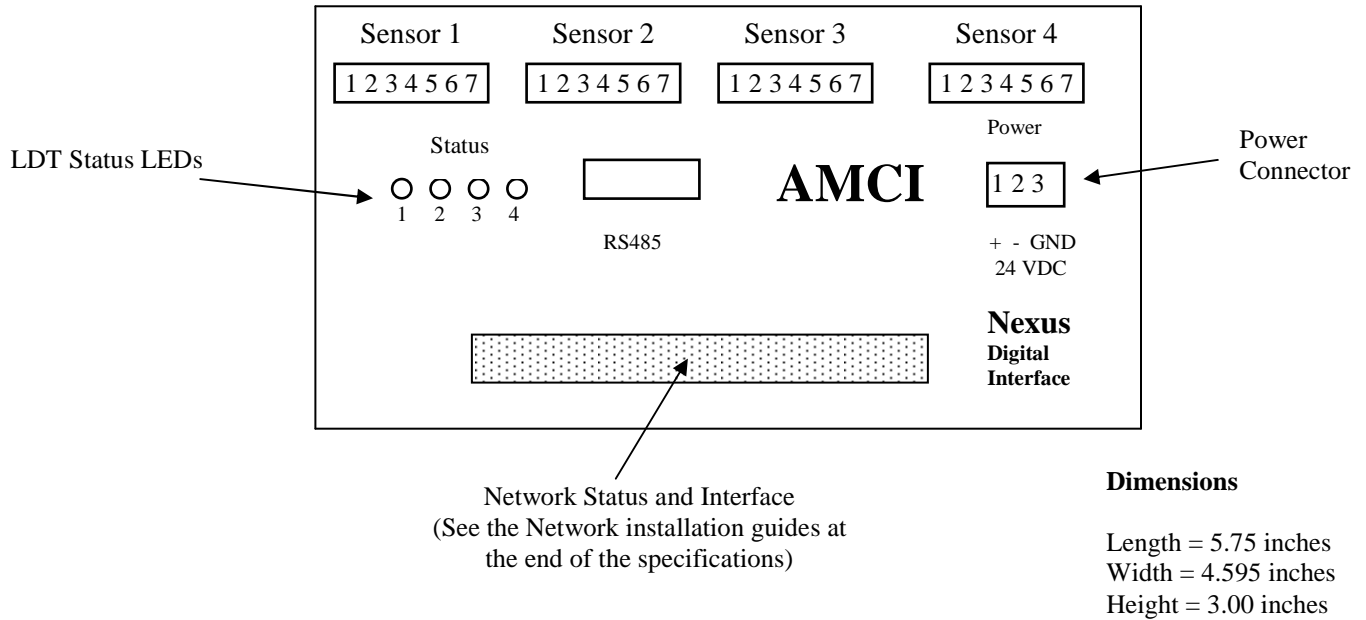

Power Connector

Pin	Function
1	+24Vdc
2	DC Common
3	Shields

The Nexus Module requires 500 mA of current @24Vdc to operate. If the sensors are being powered from the Nexus unit, add the power requirements of the sensor to those of the Nexus.

Sensor Connectors & Wiring

The Sensor Input Connectors, labeled “SENSOR 1” through “SENSOR 4” have seven contacts. The mating connectors are supplied with the NX2C4X. The AMCI part number for the mating connector is MS-7P, while the Phoenix Contact part number is MC1,5/7-ST-3,81, order number 1803620.

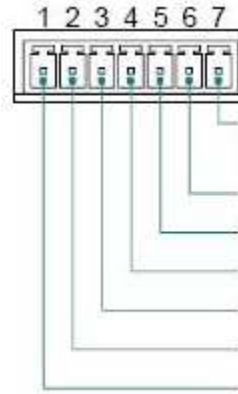

Shields
Chassis Ground
+24Vdc Output
DC Ground
-Gate or -Start/Stop
+Gate or +Start/Stop
-Interrogation
+Interrogation



The +24Vdc Output pin, (#6), is directly connected to the +24Vdc pin on the Power connector of the NX2C4X. If your LDT sensor uses +24Vdc as its power source, then you can use this pin to power the sensor. **DO NOT APPLY +24Vdc TO THIS PIN.** Doing so will damage the NX2C4X and possibly your power supply.

If your sensor uses a different supply voltage, such as +/- 15Vdc, connect the Common of both the Nexus and the sensor's power supply together, and leave the +24Vdc terminal open.

Transducer Cable Installation

Follow the transducer manufacturer's suggestions when specifying the transducer cable. Pre-assembled and tested cables are usually offered by the manufacturer. When installing the transducer cable, follow these general guidelines.

- LDT signals are low voltage, low power signals. LDT cables must use shielded cable and can be installed in conduit along with other low power cabling such as communication cables and low power ac/dc I/O lines. They cannot be installed in conduit with ac power lines or high power ac/dc I/O lines. Most factory automation manufacturers offer excellent written guidelines for cabling installation that you can refer to for additional information..
- *The shields of the transducer cable must be grounded at one point only!* When installing the cable, treat the shield as a signal carrying conductor and do not connect the shield to ground at any junction box.
 - 1) If you are making your own transducer cable, ground the shields at the NX2C4X by connecting them to the Shields pin (#7) of the Sensor Input Connector. Do not connect the shields to the body of the transducer.
 - 2) If you are using a pre-made cable, or the LDT transducer has an integral cable, verify that the shields are electrically isolated from the body of the transducer. If they are connected, then properly ground the body of the transducer and **DO NOT** connect the shields to Shields pin (#7) of the Sensor Input Connector. The preferred grounding connection for the transducers' shields is at the NX2C4X. Use this point unless the shields are connected to the body of the transducer through a pre-made or integral cable. Following this practice will eliminate ground loops that could damage the transducer or NX2C4X.

LDT Status LEDs

Function	LED Pattern
LDT OK	solid green
Clearable Transducer Fault	Flashing green
Non Clearable Transducer Fault	flashing red
Module Fault	solid red

It is possible to enable or disable the LEDs when programming the Nexus module. The default LED function has only LED 1 enabled.

Module Specifications**Throughput Time**

The throughput time of the Nexus LDT Interface is dependent on the type of unit and how its parameters are configured and represents how long the module will need to decode the position data. It does not include the time that it will take to transfer data to and from the Nexus module over the network.

NX2C4X: 2ms minimum. Maximum time dependent on the value of the length parameter and the location of the magnet on the sensor

NX2C4X-08: The update time is either 2ms or the result of $(\text{Length} * 40 * 1.3)$ whichever is greater. The result of this calculation is in μs .

Data I/O Words

NX2C4X: 28 input and 33 output words

NX2C4X-08: 136 input and 33 output words

Compatible Transducers

Sensors manufactured by Balluff, MTS, Ametek, and Turck

Above brands with start - stop or PWM (with External Interrogation) digital outputs

Number of Transducer Inputs

Four

Transducer Input Isolation

Optically Isolated (1,500 Vac)

Programmable Parameters

Count Direction

Transducer Fault Latch (Latched or Self Clearing)

Velocity Update Time (160ms or 24ms)

LDT Mode (Start/Stop or PWM)

Number of Recirculations (one or four)

Enable / Disable Channel LED

LDT Gradient

Full Scale Count

Full Scale Length

Preset Value

Data Value (position) Range

±268,435,455 counts max.

Data Value (position) Preset

Data Value can be preset to any value within the position range.

Rate of Change (velocity) Range

±268,435,455 counts per second max.

Program Memory

EEPROM. Rated for 100,000 write cycles

Data Available to Network

Data Value, Rate of Change, status bits.

NX2C4X Mounting

DIN rail or panel mount. Kit included with unit that allows customer to change mounting styles.
DIN channel, not supplied with the NX2C4X, can be EN 50 002 or EN 50 035.

Environmental Conditions

Operating Temperature: 0 to 60°C

Relative Humidity 5 to 95% (without condensation)

Storage Temperature: -40 to 85°C

NEMA Rating

NEMA 1. Must be mounted in a suitable enclosure to protect it from airborne and liquid contaminants.

Mounting the NX2C4X

The next two pages show the NX2C4X in its DIN rail and panel mount configurations. The mounting kit, included with the unit, contains two DIN brackets, two panel brackets, and four #8 screws needed to attach your choice of brackets to the NX2C4X. Note that the unit is not sealed and the NX2C4X must be installed in an adequate enclosure to protect it from environmental contaminants.

DIN Rail Mounting

As shown in the following figure, the unit can be DIN rail mounted in two ways. The brackets accept EN 50 002 or EN 50 035 channel. Note that DIN channel is not included with the NX2C4X.

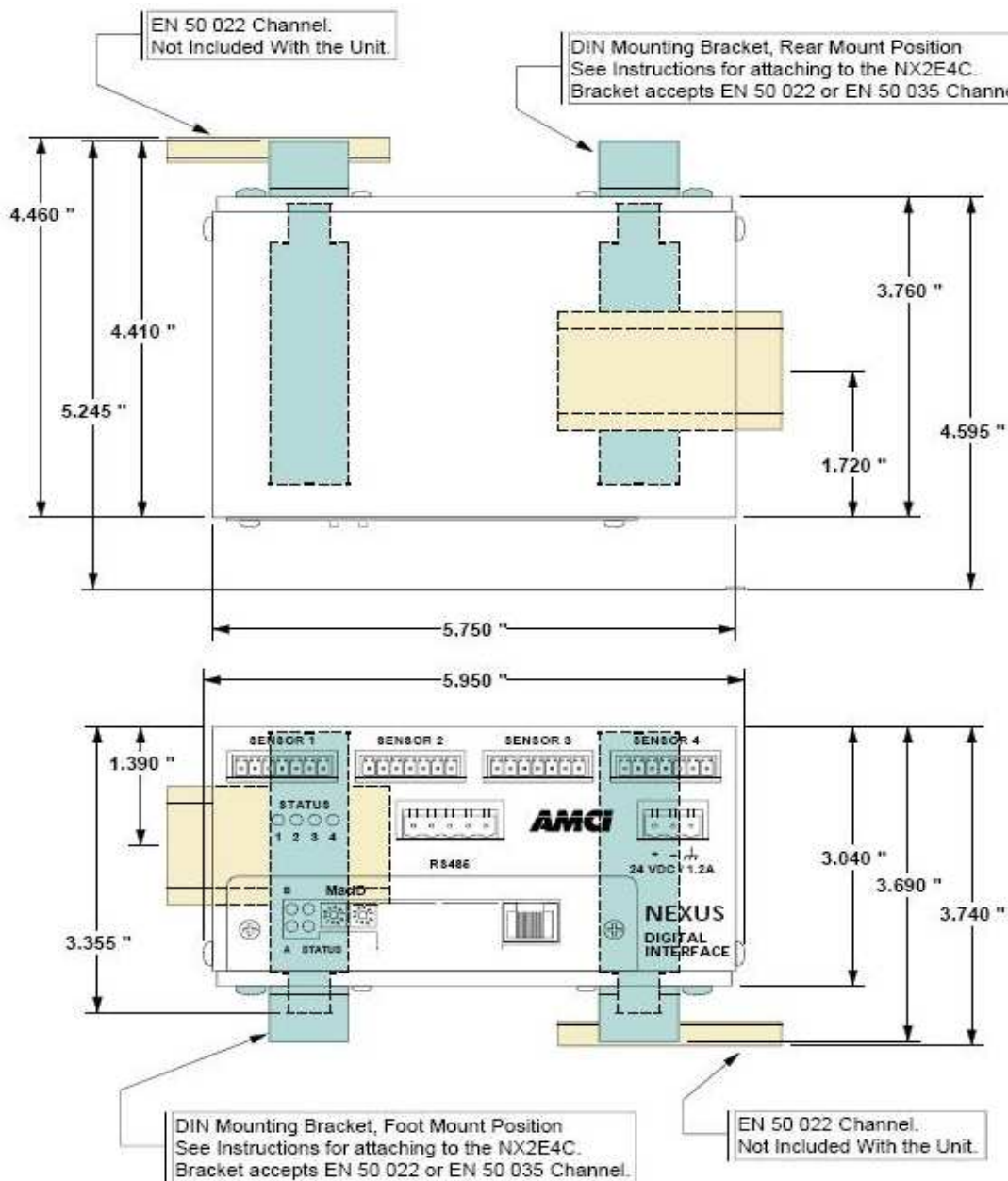

Panel Mounting

As shown in the figure below, the NX2C4X can be panel mounted in two ways. The mounting kit, included with the unit, contains the two panel brackets and four #8 screws needed to attach the brackets. The slots in the brackets for mounting the unit to the panel are made to accept #8 screws or bolts. The lengths of these screws or bolts depends on your application, and are not included with the unit.

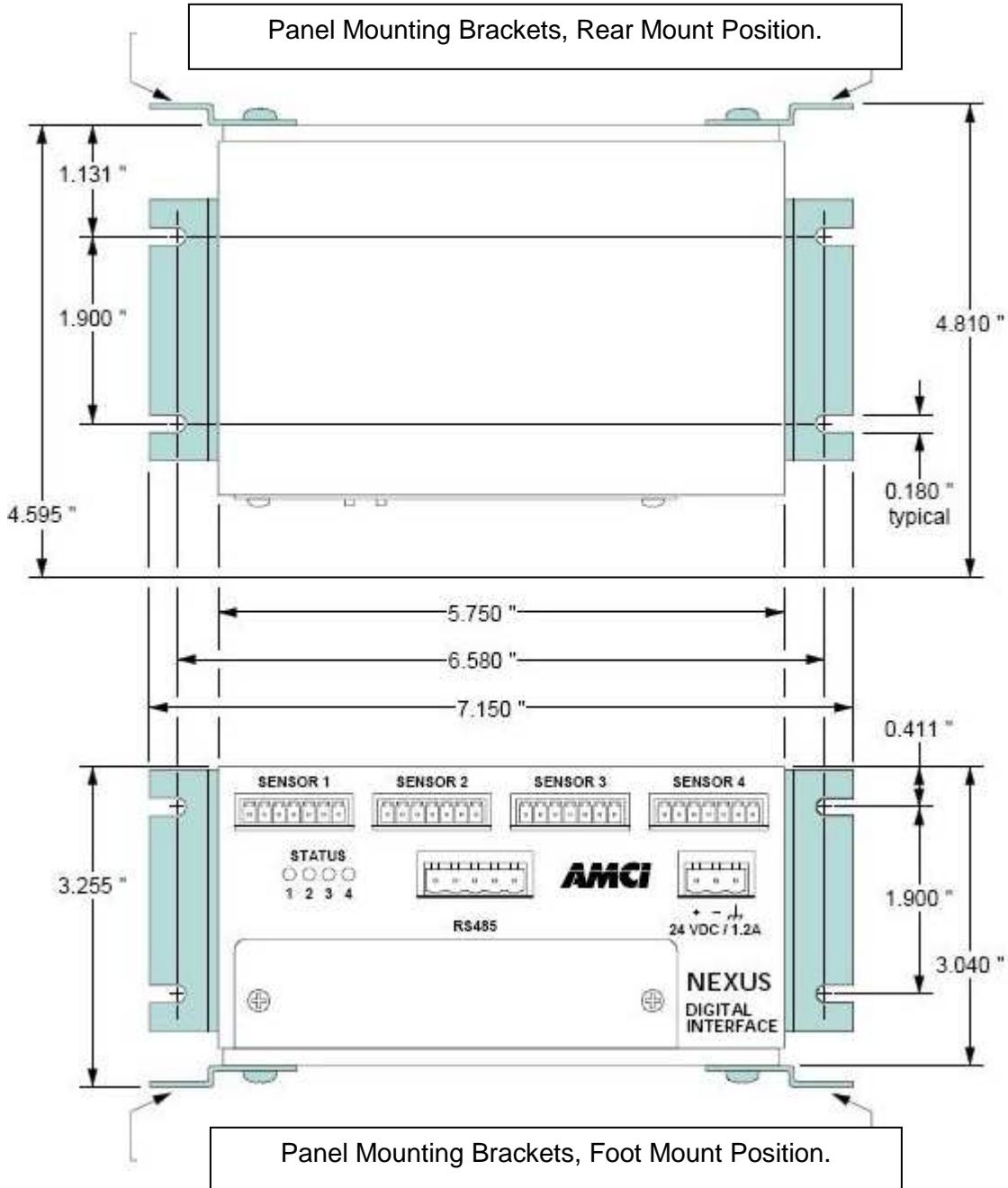

Mounting

The NX2C4X can be panel mounted in two ways, either on a DIN rail or panel mounted. The mounting kit, included with the unit, contains two DIN brackets, two panel brackets, and four #8 screws needed to attach your choice of brackets to the NX2C4X. Note that the enclosure is not sealed and the NX2C4X must be installed in an adequate enclosure to protect it from environmental contaminants.

Attaching the DIN Brackets

The following figure shows how to install the DIN brackets so that the NX2C4X can be mounted on EN 50 022 or EN 50 035 rail. Note that the bottom view of the unit is shown. The rear view is similar and the brackets are installed in the same fashion.

- 1) Remove a DIN bracket, two #8 screws, and two #8 lock washers from the mounting kit bag.
- 2) Slide the DIN bracket onto the unit.
- 3) Install the two #8 screws and lock washers to secure the bracket on the unit.
- 4) Repeat on the other side.

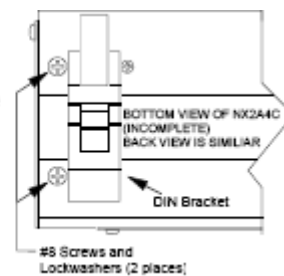

Attaching the Panel Brackets

The following figure shows how to install the panel brackets so that the NX2C4X can be securely mounted to an enclosure. Note that the bottom view of the unit is shown. The rear view is similar and the brackets are installed in the same fashion.

- 1) Remove a panel bracket, two #8 screws, and two #8 lock washers from the mounting kit bag.
- 2) Position the panel bracket onto the unit.
- 3) Install the two #8 screws and lock washers to secure the bracket to the unit.
- 4) Repeat on the other side.

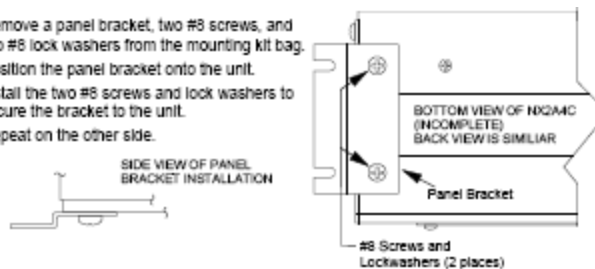

Chapter 2: Programmable Parameters

The NX2C4X is configured by programming its Programmable Parameters. These parameters are sent to the NX2C4X using the output registers assigned to it on the network.

Count Direction: This parameter gives you the ability to reverse the direction of motion needed to increase the position count. For simplicity's sake, the two values for this parameter are called *Positive Direction* and *Negative Direction*. When this parameter is set to its default of *Positive*, the Data Value is not changed. When this parameter is set to *Negative*, the Data Value is multiplied by -1 before it is reported. For linear transducers, this has the effect of reversing the direction of motion needed to increase the count. When using LDT's and the Count Direction is set to *Positive*, the Data Value usually increases as the magnet moves away from the head of the LDT. When the Count Direction is set to *Negative*, the Data Value increases as the magnet moves towards the head of the LDT. You will probably need to Apply the Preset to the Data Value after you program the Count Direction parameter.

Transducer Fault Latch - Transducer faults can be caused by improper wiring, electrical noise, or a damaged transducer. When the unit detects a fault condition, it reports this fault over the backplane. Normally, a transducer fault is not latched by the NX2C4X module and the Transducer Fault conditions will be cleared as soon as the NX2C4X module detects valid LDT signals. If you have a situation where electrical noise is causing spurious transducer faults that you can safely ignore, leave this parameter in its default condition. However, if you want to reliably capture these transient faults, then you must enable the Transducer Fault Latch parameter. In this case, you must send a Clear Error command to the NX2C4X module to clear the fault. The default Transducer Fault Latch value is set to *Self Clearing*.

Velocity Update Time: The Velocity Update Time parameter sets the amount of time between Rate of Change information updates to the PLC. Its can be set to either 160 milliseconds or 24 milliseconds, with 160 milliseconds being the default. Decrease the time between updates for faster response to changes in this value. Increase the time between updates for better averaging of this value. The Velocity update time **does not affect** the rate at which the position data is updated.

The Velocity data is measured in Counts/Second. For example, if you have programmed the NX2C4X module for 0.001 inch resolution, and if the magnet is moving at a rate of two inches per second, then the NX2C4X module will report a velocity value of 2000 counts / second.

LDT Mode – A Configuration Word bit is used to select the desired LDT mode, which can be one of the two following modes.

- Start/Stop Mode (default)
- PWM Mode (external interrogation only, with either 1 or 4 recirculations)

Number of Recirculations: This bit level parameter controls how many times the NX2C4X will interrogate the sensor before reporting the position data to the network. For correct readings, this parameter must match the number of recirculations expected by PWM sensors.

LED Enable: This parameter gives you the ability to enable or disable the *Unit Status LED* of the corresponding Sensor Input Channel. When disabled, the LED is always off and does not show the status of the NX2C4X. The channel will continue to function, regardless of the state of the LED.

LDT Gradient (Wire Speed) - This is a calibration parameter supplied by the LDT manufacturer and defines how fast the pulse travels down the waveguide of the sensor. The data reported by the NX2C4X module will be repeatable, but not accurate, if an incorrect Gradient value is used.

LDT manufacturers specify the gradient in $\mu\text{Sec}/\text{inch}$, $\mu\text{sec}/\text{mm}$, or meters/second.

The gradient value used by the NX2C4X module has a range of 80000 to 99999, a default value of 90000 (for 9.0000 $\mu\text{sec}/\text{inch}$) and is always programmed in $\mu\text{sec}/\text{inch}$. Use the following formulas to convert from $\mu\text{sec}/\text{mm}$ or meters/second to $\mu\text{sec}/\text{inch}$.

$$\begin{aligned}\text{Gradient in } \mu\text{sec}/\text{inch} &= (\text{Gradient in } \mu\text{sec}/\text{mm} * 25.4 \text{ mm}/\text{inch}) \\ \text{Gradient in } \mu\text{sec}/\text{inch} &= 1 / (\text{Gradient in meters}/\text{sec} * 0.00003937)\end{aligned}$$

Full Scale Length - Most commonly set to the expected length of travel, the Full Scale Length can actually be any value that simplifies the Full Scale Count value. The range of values is 2 to 800 inches. Default value of 40.

Full Scale Count - Sets the number of counts over the specified Full Scale Length. The range of values is 2 to (Full Scale Length * 1000) Default value of 40,000.

Preset Value: The zero position of the LDT encoder's Data Value may not match the zero position of the application machine. The Preset Value parameter gives you the ability to offset the Data Value from the actual LDT data to a value that will be more useful for your application.

Programming the Preset Value parameter does not change the Data Value. It is stored in the NX2C4X module's memory until the module sees the Apply Preset bit set during a programming cycle.

Apply Preset: Offsetting the Data Value to the Preset Value is a two step operation. First, the Preset Value is programmed with the other setup parameters. Second, setting the Apply Preset bit in the output registers will change the Data Value to the Preset Value. These two operations cannot be performed during the same programming cycle.

Setting the Apply Preset bit causes the module to generate an internal offset value that is applied to the Data Value before it is reported to the PLC. This internal offset is saved in the NX2C4X module's memory, so it is not necessary to home the module at every power up. Please note that programming a channel's setup data will clear the internal offset generated by an Apply Preset operation.

**WARNING**

The NX2C4X module's EEPROM memory is guaranteed for 100,000 write cycles before writing to it will cause it to fault. Therefore continuously applying the Preset should be avoided. If your application requires you to continuously apply the Preset, consider calculating and applying the Preset in your PLC program.

**NOTE**

The Nexus LDT measures only in units of inches. However, the Full Scale Length and Full Scale Count parameters can be used to scale the position data so that it is reported in millimeters. To accomplish this, set the Length to its inch value and the Full Scale Count to (254 * Length in inches). The resolution will be 0.1mm.

Chapter 3: Single Magnet LDT Interface NX2C4X (28 Input Words and 33 Output Words)

The single magnet Digital Interface can interface with sensors that have either Start/Stop or Pulse Width Modulated outputs.



Because the data from the Nexus LDT interface module may be updated asynchronously to the program scan, AMCI recommends that the input data be buffered by copying it into internal registers before it is used by the ladder logic program.

Input Words for LDT with Recirculations or Pulse Width Modulation

Channel	Word #	LDT Parameter	Units
1	0	Channel 1 Status	
	1	Channel 1 upper 4 digits position	Scaled
	2	Channel 1 lower 4 digits position	Counts
	3	Channel 1 upper 4 digits velocity	Counts / Second
	4	Channel 1 lower 4 digits velocity	
2	5	Channel 2 Status	
	6	Channel 2 upper 4 digits position	Scaled
	7	Channel 2 lower 4 digits position	Counts
	8	Channel 2 upper 4 digits velocity	Counts / Second
	9	Channel 2 lower 4 digits velocity	
3	10	Channel 3 Status	
	11	Channel 3 upper 4 digits position	Scaled
	12	Channel 3 lower 4 digits position	Counts
	13	Channel 3 upper 4 digits velocity	Counts / Second
	14	Channel 3 lower 4 digits velocity	
4	15	Channel 4 Status	
	16	Channel 4 upper 4 digits position	Scaled
	17	Channel 4 lower 4 digits position	Counts
	18	Channel 4 upper 4 digits velocity	Counts / Second
	19	Channel 4 lower 4 digits velocity	
	20	0	
	21	0	
	22	0	
	23	0	
	24	0	
	25	0	
	26	0	
	27	0	

Note 1: A NX2C4P unit will require that you configure your scanner for all twenty-eight 16 bit input words.

Note 2: To reduce the amount of data transferred, the number of input words can be reduced to 20 for an Ethernet IP system, and 22 for a ControlLogix system.

Note 3: A ControlLogix system using ControlNet will require 22 input words. The first two words will always be zero, and the Channel 1 Status Word will be located in word 2.

NX2C4X Status Word Layout

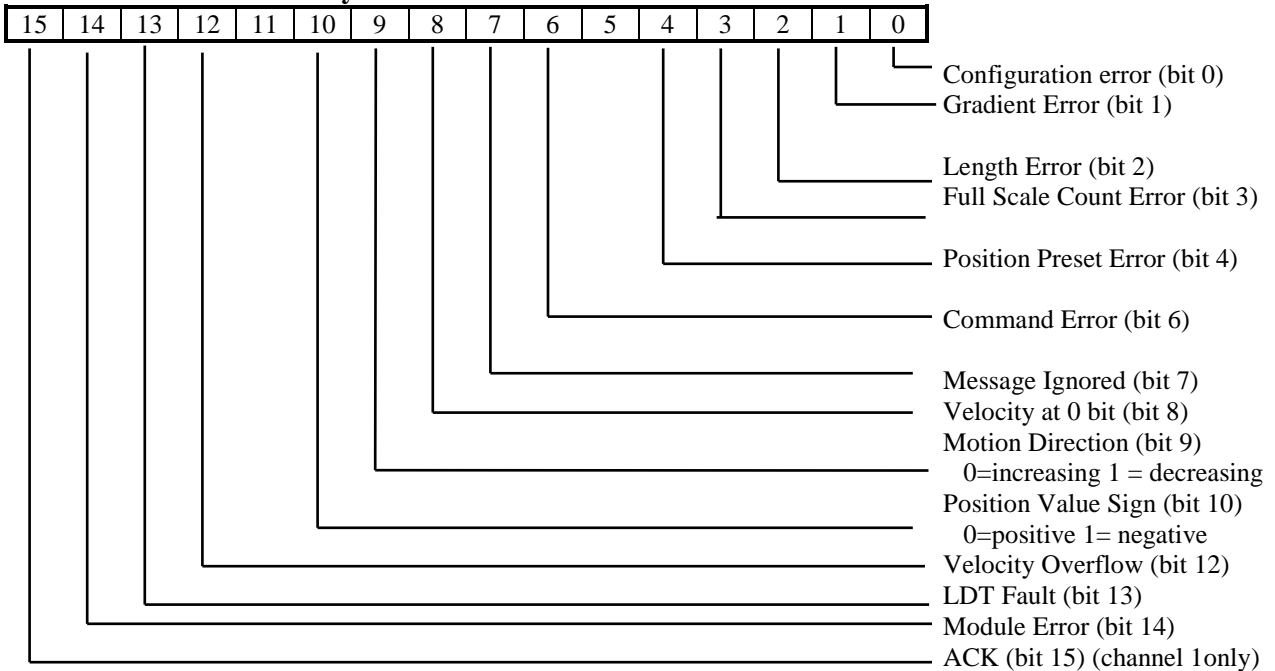

- Configuration Error: Set if any of the unused bits in the configuration word are set
- Gradient Error: This bit is set if the Gradient Value is outside the expected range 80000...99999, or if the lower gradient word exceeds 9999.
- Length Error: Full Scale Length is outside the expected range (2 to 800)
- Full Scale Count Error: Set if the Full Scale Count is outside the range of (2 to (Length * 1000))
- Position Preset Error: Set if the preset value is outside of the range of $\pm 268,435,455$
- Command Error: Set if any of unused bits in the command word are set, or if both the Program Channel and Apply Preset bits are set during the same programming sequence.
- Message Ignored: Set if an attempt is made to program a parameter if an error already exists on a different parameter, or if an attempt is made to apply the preset value to a channel that is faulted. This bit is not set if the same channel is programmed a second time with incorrect data.
- Motion Direction: This bit will be "0" if the position is increasing, or "1" if the position is decreasing. The bit will remain in its last state when there is no motion.
- Position Value Sign: This bit will be "0" if the position is positive, or "1" if the position is negative.
- Velocity at Zero: This bit will be set if there has been no motion for the last portion of the Velocity Update Time.
- Velocity Overflow: This bit will be set if the rate of change value exceeds 2^{32} counts per second. When this occurs, the last valid value is sent to the processor.
- LDT Fault: This bit will be set if a transducer fault has been detected caused by improper programming, improper installation or faulty transducer.
- Module Fault: Set on EEPROM or PLD fault.
- Acknowledge Bit: Set when the transmit bit is set. This bit is present only in the channel 1 status data.

NX2C4X Output Words

Channel	Word	LDT Set Up Word	Range
All	0	Control	See Below
1	1	Channel 1: Configuration	See Below
	2	Channel 1: Upper 1 Digit Gradient	80,000 to 99,999
	3	Channel 1: Lower 4 Digits Gradient	
	4	Channel 1: Upper 2 Digits Full Scale Count	2 to (Full Scale Length * 1000)
	5	Channel 1: Lower 4 Digits Full Scale Count	
	6	Channel 1: Full Scale Length	2 to 800
	7	Channel 1: Upper 4 Digits Preset Value + sign	±268,435,455
	8	Channel 1: Lower 4 Digits Preset Value	
2	9	Channel 2: Configuration	See Below
	10	Channel 2: Upper 1 Digit Gradient	80,000 to 99,999
	11	Channel 2: Lower 4 Digits Gradient	
	12	Channel 2: Upper 2 Digits Full Scale Count	2 to (Full Scale Length * 1000)
	13	Channel 2: Lower 4 Digits Full Scale Count	
	14	Channel 2: Full Scale Length	2 to 800
	15	Channel 2: Upper 4 Digits Preset Value + sign	±268,435,455
	16	Channel 2: Lower 4 Digits Preset Value	
3	17	Channel 3: Configuration	See Below
	18	Channel 3: Upper 1 Digit Gradient	80,000 to 99,999
	19	Channel 3: Lower 4 Digits Gradient	
	20	Channel 3: Upper 2 Digits Full Scale Count	2 to (Full Scale Length * 1000)
	21	Channel 3: Lower 4 Digits Full Scale Count	
	22	Channel 3: Full Scale Length	2 to 800
	23	Channel 3: Upper 4 Digits Preset Value + sign	±268,435,455
	24	Channel 3: Lower 4 Digits Preset Value	
4	25	Channel 4: Configuration	See Below
	26	Channel 4: Upper 1 Digit Gradient	80,000 to 99,999
	27	Channel 4: Lower 4 Digits Gradient	
	28	Channel 4: Upper 2 Digits Full Scale Count	2 to (Full Scale Length * 1000)
	29	Channel 4: Lower 4 Digits Full Scale Count	
	30	Channel 4: Full Scale Length	2 to 800
	31	Channel 4: Upper 4 Digits Preset Value + sign	±268,435,455
	32	Channel 4: Lower 4 Digits Preset Value	

1. The Gradient, Full Scale Count, and Preset Value parameters are divided into two words. The upper word contains the 10,000 and above places, the lower word contains the 1s, 10s, 100s, and 1000s places. For example, if your Full Scale Count value is 16,500, then the upper word would be equal to “1” and the lower word would be equal to “6500.”
2. The preset value has a range of ±268,435,455 and a default of zero. Negative Preset values are transmitted with bit 15 set in the upper word of the corresponding Preset Value.
3. The Nexus LDT measures only in inches. However, the Full Scale Length and Full Scale Count parameters can be used to scale the position data so that it is reported in millimeters. To accomplish this, set the Length to its inch value and the Full Scale Count to (254 * Length in inches). The resolution will be 0.1mm.

NX2C4X Control Word Layout

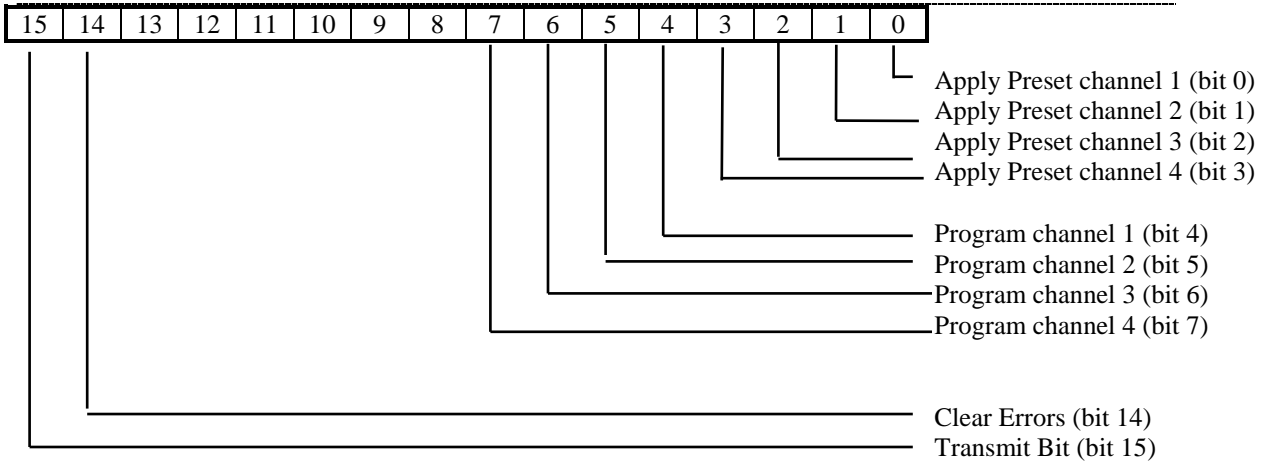

Note: A Command Error is generated if you try to both preset and program a channel in a single programming sequence. However, it is possible to program a channel while presetting a different channel.

NX2C4X Configuration Word Layout

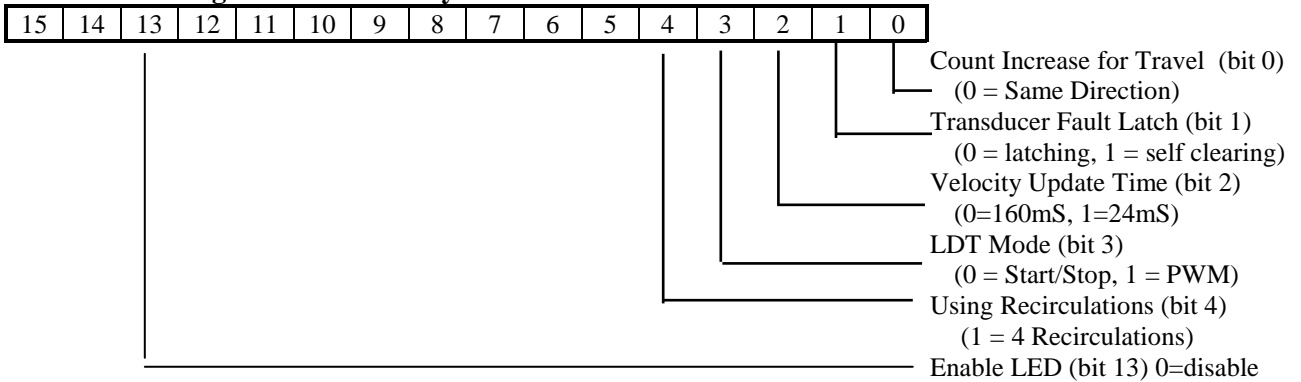

1. The Configuration Word has a default value of 0.
2. All bits that are not used, 5 to 12, 14, and 15, must be reset to zero or a configuration error will be generated.
3. Changing the direction of increasing counts sets the position sign bit in the input register's status data. The absolute value of the position data is not affected.
4. Changing the sensor type from RPM to DPM or vice versa will cause the Nexus unit to indicate a clearable transducer fault, unless the unit has also been configured to self clear the transducer fault.
5. The position update time is dependent on the programmed length parameter and an internal calculation. If the result of multiplying the $(Length * 40 * 1.3\mu s)$ is less than 2ms, then the position is updated every 2ms. However, if the result of this calculation is greater than 2ms, than the result of this calculation is used for the position update time.

Chapter 4: Multiple Magnet LDT Interface NX2C4X-08

(136 Input Words and 33 Output Words)

(A maximum of 16 magnets can be used on each sensor)



Because the data from the Nexus LDT interface module may be updated asynchronously to the program scan, AMCI recommends that the input data be buffered by copying it into internal registers before it is used by the ladder logic program.

Input Words for LDT with Multiple Magnets

Note: A ControlLogix system using ControlNet will require 138 input words. The first two words will always be zero, and the Channel 1 Status Word will be located in word 2.

Word #	LDT Parameter
0	Channel 1, Status
1	Channel 1, Position Signs Word
2	Channel 1, Magnet 1 upper 4 digits position
3	Channel 1, Magnet 1 lower 4 digits position
4	Channel 1, Magnet 2 upper 4 digits position
5	Channel 1, Magnet 2 lower 4 digits position
6 to 33	Channel 1, Magnet 3 ... 16 position
34	Channel 2, Status
35	Channel 2, Position Signs Word
36	Channel 2, Magnet 1 upper 4 digits position
37	Channel 2, Magnet 1 lower 4 digits position
38 to 67	Channel 2, Magnet 2 ... 16 position
68	Channel 3, Status
69	Channel 3, Position Signs Word
70	Channel 3, Magnet 1 upper 4 digits position
71	Channel 3, Magnet 1 lower 4 digits position
72 to 101	Channel 3, Magnet 2 ... 16 position
102	Channel 4, Status
103	Channel 4, Position Signs Word
104	Channel 4, Magnet 1 upper 4 digits position
105	Channel 4, Magnet 1 lower 4 digits position
106 to 135	Channel 4, Magnet 2 ... 16 position

Note 1: The position sign words are used to indicate the sign of each of the 16 magnets in the channel. If the bit is reset, “0”, the position is positive, if the bit is set, “1”, the position is negative. Bit 0 = magnet 1 position sign, bit 1 = magnet 2 position sign, ... bit 15 = magnet 16 position sign.

NX2C4X-08 Status Word

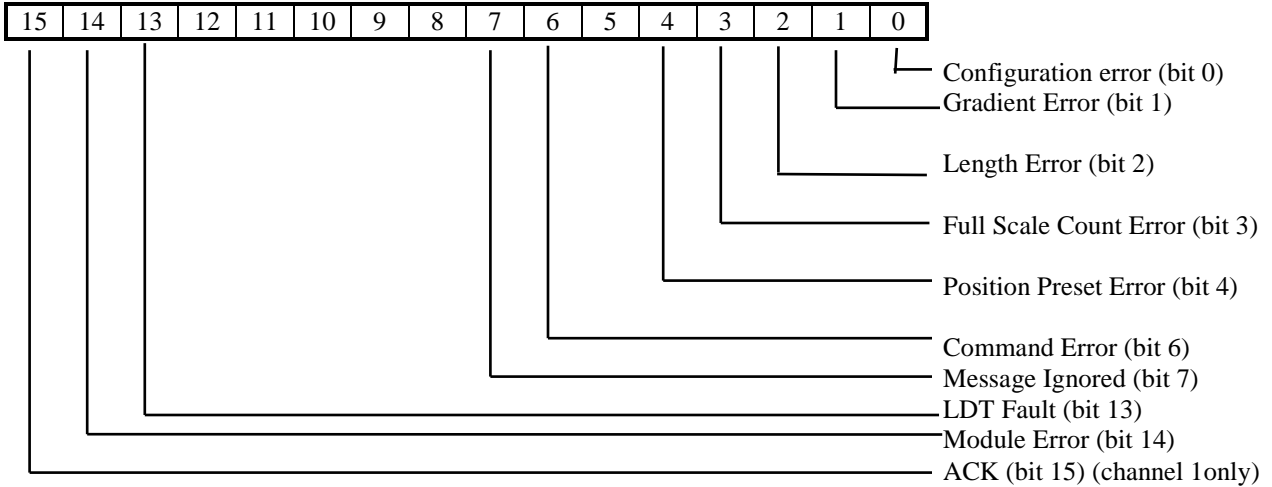

- Configuration Error: Set if any of the unused bits in the configuration word are set, if the length parameter is not twice the number of magnets, or if the channel is configured to operate with a DPM sensor and more than one magnet.
- Gradient Error: This bit is set if the Gradient Value is outside the expected range 80000...99999, or if the lower gradient word exceeds 9999.
- Length Error: Full Scale Length is outside the expected range (2 to 800)
- Full Scale Count Error: Set if the Full Scale Count is outside the range of (2 to (Length * 1000))
- Position Preset Error: Set if the preset value is outside of the range of $\pm 268,435,455$
- Command Error: Set if any of unused bits in the command word are set, or if both the Program Channel and Apply Preset bits are set during the same programming sequence.
- Message Ignored: Set if an attempt is made to program a parameter if an error already exists on a different parameter, or if an attempt is made to apply the preset value to a channel that is faulted. This bit is not set if the same channel is programmed a second time with incorrect data.
- LDT Fault: This bit will be set if a transducer fault has been detected caused by improper programming, improper installation or faulty transducer. This bit will also be set if the unit has been programmed for more magnets than are present on the sensor.
- Module Fault: Set on EEPROM or PLD fault.
- Acknowledge Bit: Set when the transmit bit is set. This bit is present only in the channel 1 status data.

NX2C4X-08 Output Words

Channel	Word	LDT Set Up Word	Range
All	0	Control	See Below
1	1	Channel 1: Configuration	See Below
	2	Channel 1: Upper 1 Digit Gradient	80,000 to 99,999
	3	Channel 1: Lower 4 Digits Gradient	
	4	Channel 1: Upper 2 Digits Full Scale Count	2 to (Full Scale Length * 1000)
	5	Channel 1: Lower 4 Digits Full Scale Count	
	6	Channel 1: Full Scale Length	2 to 800
	7	Channel 1: Upper 4 Digits Preset Value +sign	±268,435,455
	8	Channel 1: Lower 4 Digits Preset Value	
2	9	Channel 2: Configuration	See Below
	10	Channel 2: Upper 1 Digit Gradient	80,000 to 99,999
	11	Channel 2: Lower 4 Digits Gradient	
	12	Channel 2: Upper 2 Digits Full Scale Count	2 to (Full Scale Length * 1000)
	13	Channel 2: Lower 4 Digits Full Scale Count	
	14	Channel 2: Full Scale Length	2 to 800
	15	Channel 2: Upper 4 Digits Preset Value + sign	±268,435,455
	16	Channel 2: Lower 4 Digits Preset Value	
3	17	Channel 3: Configuration	See Below
	18	Channel 3: Upper 1 Digit Gradient	80,000 to 99,999
	19	Channel 3: Lower 4 Digits Gradient	
	20	Channel 3: Upper 2 Digits Full Scale Count	2 to (Full Scale Length * 1000)
	21	Channel 3: Lower 4 Digits Full Scale Count	
	22	Channel 3: Full Scale Length	2 to 800
	23	Channel 3: Upper 4 Digits Preset Value + sign	±268,435,455
	24	Channel 3: Lower 4 Digits Preset Value	
4	25	Channel 4: Configuration	See Below
	26	Channel 4: Upper 1 Digit Gradient	80,000 to 99,999
	27	Channel 4: Lower 4 Digits Gradient	
	28	Channel 4: Upper 2 Digits Full Scale Count	2 to (Full Scale Length * 1000)
	29	Channel 4: Lower 4 Digits Full Scale Count	
	30	Channel 4: Full Scale Length	2 to 800
	31	Channel 4: Upper 4 Digits Preset Value + sign	±268,435,455
	32	Channel 4: Lower 4 Digits Preset Value	

1. The Gradient, Full Scale Count, and Preset Value parameters are divided into two words. The upper word contains the 10,000 and above places, the lower word contains the 1s, 10s, 100s, and 1000s places. For example, if your Full Scale Count value is 16,500, then the upper word would be equal to “1” and the lower word would be equal to “6500.”
2. The preset value has a range of ±268,435,455 and a default of zero. Negative Preset are transmitted with bit 15 set in the upper word of the corresponding Preset Value.
3. The Nexus LDT measures only in inches. However, the Full Scale Length and Full Scale Count parameters can be used to scale the position data so that it is reported in millimeters. To accomplish this, set the Length to its inch value and the Full Scale Count to (254 * Length in inches). The resolution will be 0.1mm.

NX2C4X-08 Control Word Layout

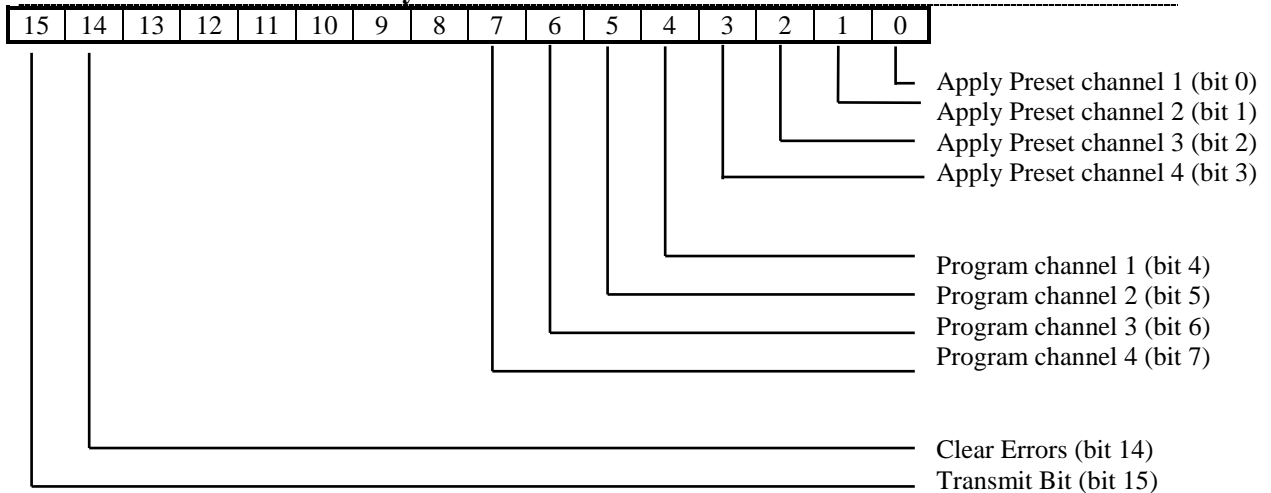

1. A Command Error is generated if you try to both preset and program a channel in a single programming sequence. However, it is possible to program a channel while presetting a different channel.
2. Applying the Preset to an LDT with Multiple Magnets sets the position for the first magnet to the programmed preset value. The offset that was necessary to set the first magnet to the preset value is also applied to the remaining magnets, maintaining the distance between each of the magnets.

NX2C4X-08 Configuration Word Layout

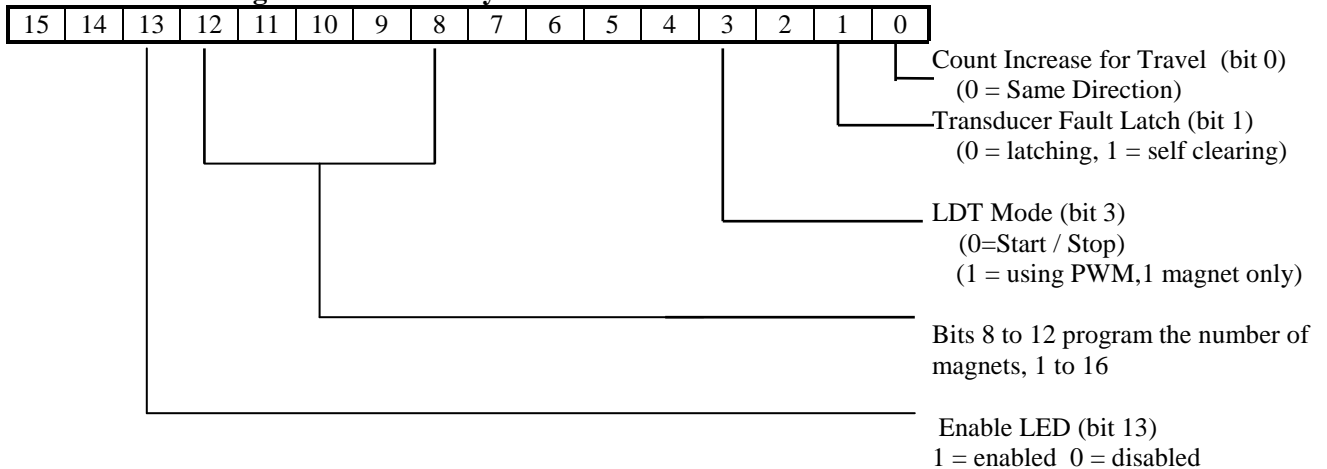

1. The Configuration Word has a default value of 0.
2. Bits 2, 4 to 7, 14, and 15 must be reset or a configuration error will be generated.
3. Bits 8 through 12 set the number of magnets in use. The range is 1 to 16. Entering a value of zero will generate a configuration error.
4. The length parameter must be at least twice the number of magnets, or a configuration error will be generated.
5. An LDT error will be reported if the unit has been programmed for more magnets than are present on the sensor. However, the module will operate correctly if the number of magnets on the sensor exceeds the value programmed.

6. The module can only be configured to accept signals from a sensor with a Digital Personality module if the number of magnets is set to 1. If the number of magnets is greater than 1, programming the module for a DPM sensor will cause a configuration error to be generated.
7. It is not possible to program the multiple magnet module for more than one recirculation.
8. Multiple magnets should be kept at least three inches from each other. If the magnets are moved together closer than this, the position data of the magnet farther from the head of the sensor will increase. If the magnets are moved closer together still, the return signal from the farther magnet will disappear, and the unit will go into transducer fault.
9. The update time is either 2ms or the result of $(\text{Length} * 40 * 1.3)$ whichever is greater. The result of this calculation is in μs .

Chapter 5 General Programming Notes and Programming Sequence

General Programming Notes

1. It is possible to enable or disable the four status LEDs. The channels are always enabled, and will function normally, even if the LED is disabled. By default, only the channel 1 LED is enabled.
2. It is possible to program multiple channels at one time.
3. When programming a channel, all of the data must be correct before it will be acted upon. However, if the data on one channel is incorrect, and the data on another channel is correct, then the data from the correct data will be accepted even if the channel with the incorrect data comes first.
4. If a programming error exists on any of the channels, the error must be cleared before a different channel can be programmed.
5. It is not possible to program and apply the preset value with one programming sequence. However, it is possible to program one channel and apply the preset to another channel.
6. Balluff recommends that only their magnets be used on their transducers.
7. Default parameters are loaded with jumper strap installed on JP3 at power up.
8. The Gradient, Full Scale Count, and Preset Value parameters, as well as the input position and velocity data, are divided into two words. The upper word contains the 10,000 and above places, the lower word contains the 1s, 10s, 100s, and 1000s places. For example, if your Full Scale Count value is 16,500, then the upper word would be equal to "1" and the lower word would be equal to "6500."

To combine the position or velocity data into one 32 bit register, multiply the upper word by 10000 and add the lower word to it.

Programming Sequence

1. The ladder logic program writes the data into the output registers.
2. The ladder logic program then sets the transmit bit.
3. When the module detects the 0 to 1 transition of the transmit bit, it will respond by setting any error bits and the Acknowledge bit in the input registers.
4. When the ladder logic program sees that the Acknowledge bit is set, it will examine any error bits, and then reset the transmit bit.
5. The module will reset the Acknowledge bit.
6. The programming sequence is now complete.

Chapter 6: Network Connections

NX2C4C ControlNet Hardware Overview

Note: A ControlLogix system using ControlNet will require 22 input words for the NX2C4C and 138 input words for the NX2C4C-08. The first two words will always be zero, and the Channel 1 Status Word will be located in word 2.

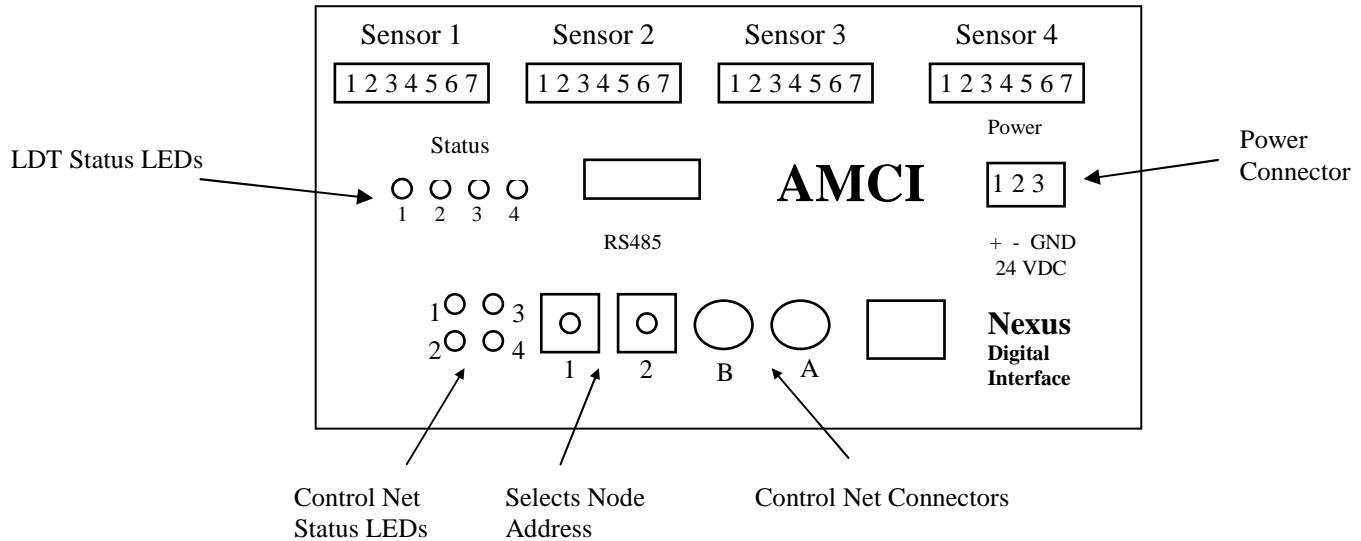

ControlNet Connectors

The Nexus module has two BNC network connections labeled A and B. Either can be used, depending on how the network configuration.

Node Address Selection

The Nexus module has two rotary switches used to set the module's address on the network. Any node from 0 to 99 can be selected. Switch 1 sets the one digit and switch 2 sets the 10s digit of the address. For example, if the Nexus is to be installed at node 46, switch 1 would be set to 6, and switch 2 would be set to 4. Note, changing the node address only takes affect at power up. Changing the address while power is applied to the Nexus module will generate a minor fault.

Network Update Time

The Nexus LDT Interface has a minimum network update time of 5ms.

ControlNet Status LEDs

The following table describes the function of the four network status LEDs.

LED Number	Name	LED Pattern	Function
1	Channel B status	Solid Green Flashing Red/Off Solid Off	Channel Operating Correctly Channel Disconnected from Network Channel Disabled
2	Channel A status	Solid Green Flashing Red/Off Solid Off	Channel Operating Correctly Channel Disconnected from Network Channel Disabled
3	Module Owned	Solid Green Off Solid Red	Network Card is communicating with Nexus Network Card is not communicating with Nexus Incorrectly Configured Network. Possible causes are incorrect Node #, Number of I/O words, or Comm format.
4	Module Status	Flashing Green Solid Green Flashing Red Solid Red	Network Card is waiting for initialization Module is initialized and operating correctly Minor Fault (For example Node address changed) Major Fault, module must be restarted

Note: If the Nexus module is removed from the Network, than both LEDs 1 and 2 will flash RED.

Quick Start Guide AMCI Nexus to ControlLogix

1. With the power off, use the rotary switches on the Nexus to select the desired node address.
2. Connect the Nexus to the ControlNet using a ControlNet Tap to coax media. Either the A or B port can be used, depending on how your network is configured.
3. Apply power to the Nexus unit.
4. Start RSLogix 5000.
5. Start RSLinx and establish communications to the ControlLogix system.
6. Configure the ControlLogix hardware system, processor and discrete I/O. If it is not already present, also add the ControlNet adapter 1756-CNB(R) module to the system.
7. Right-click on the 1756-CNB(R) module and Click on **New Module...**
8. Define the Nexus LDT Interface as a generic CONTROLNET-MODULE. Click on **OK** and define the properties as follows.

Name: *Your Choice*
Description: *Your Choice*
Comm Format: Data-INT (**must be Data-INT**)
Node: Set it to the same value as the Node address on the Nexus Digital Interface
Assembly Instance – 100, Input – 22 for the NX2C4C
 138 for the NX2C4C-08
Assembly Instance – 150, Output – 33 for the NX2C4C
 33 for the NX2C4C-08
Assembly Instance – 110, Config – 0 for all versions of the Nexus LDT Interface

9. Click on **Next>**

10. Define the RPI. The minimum value is 5.0ms, however the value may be set higher.
11. Click **Finish**.
12. Save and Download the file to the Processor
13. Start RSNetworx for ControlNet and either open an existing project or create a new one.
14. If this is the first time using the Nexus LDT Interface, register the **NX2C4C_R01.eds** or the **NX2C4C-08_R01.eds** EDS and icon files. These files are available from the driver file section of AMCI's website www.AMCI.com.
15. Go Online. RSNetWorx will scan the ControlNet network and should discover the Digital Interface module that you are using.
16. Click on the Enable Edits checkbox and then save the project.

At this point, the 1756-CNB(R) should be communicating; steady green LED and the top right LED (ControlNet Status LED #3) for the NEXUS communication should be on.

Go online to the ControlLogix processor. Select the **Logic** menu, followed by **Monitor Tags**. The data associated with the Nexus LDT Interface is available under the name you chose when configuring it.

Quick Start Guide

AMCI Nexus to PLC-5

1. With the power off, use the rotary switches on the Nexus to select the desired node address.
2. Connect the Nexus to the ControlNet using a ControlNet Tap to coax media. Either the A or B port can be used, depending on how your network is configured.
3. Apply power to the Nexus unit.
17. Start RSNetworx. If this is the first time using the Nexus LDT Interface, register the **NX2C4C_R01.eds** or the **NX2C4C-08_R01.eds** EDS and icon files. These files are available from the driver file section of AMCI's website www.AMCI.com.
4. From RSNetworx for ControlNet, go Online. After browsing the network, the Digital Interface will appear as an "Extra Device" at the node selected by the Nexus' rotary switches.
5. Click the **Enable Edits** checkbox and choose "Use online data (upload)". Click **OK**. At this point you can right click on the Nexus LDT Interface icon and select **Properties** from the pop-up menu. In the properties window, you can change the name associated with the unit and add a description.
6. Go Offline.
7. Click the **Enable Edits** checkbox.
8. Right Click on the PLC-5 icon and click on **Scanlist Configuration** in the pop-up menu.
9. In the Device Name column, right click on the name of the Nexus unit, and click on **Insert Connection** in the pop-up menu. The Connection Properties window will appear on the screen.
10. If needed, set the Input Size and Input Address of the Data Input File. This file resides in the PLC-5 and is used by all of the ControlNet nodes. Therefore, it must be large enough to hold all of the input data on the network. The maximum number of words that the two versions of the Nexus LDT Interface transfer to the PLC is shown below.

20 Input words for the NX2C4C
136 Input words for the NX2C4C-08

11. If needed, set the Output Size and Output Address of the Data Output File. This file resides in the PLC-5 and is used by all of the ControlNet Nodes. Therefore, it must be large enough to hold all of the output data on the network. The maximum number of words that the two versions of the Nexus LDT Interface receive from the PLC-5 is shown below.

- 33 Output words for the NX2C4C
- 33 Output words for the NX2C4C-08

12. Set the Request Packet Interval time. This has a minimum acceptable value of five milliseconds, but can be set higher.
13. Click OK to close the Connection Properties window. In the Scanlist Configuration window, save the changes and close the window.
14. Go Online.
15. Verify that the PLC is in Program Mode.
16. Click on **Network** in the toolbar select **Download to Network** from the pull down menu that appears. After the download is complete, the Nexus unit should be communicating with the PLC.

NX2C4D DeviceNet Hardware Overview

Because DeviceNet does not support the transfer of 136 output words, a DeviceNet version of the Multiple Magnet Nexus unit, the NX2C4D-08, does not exist.

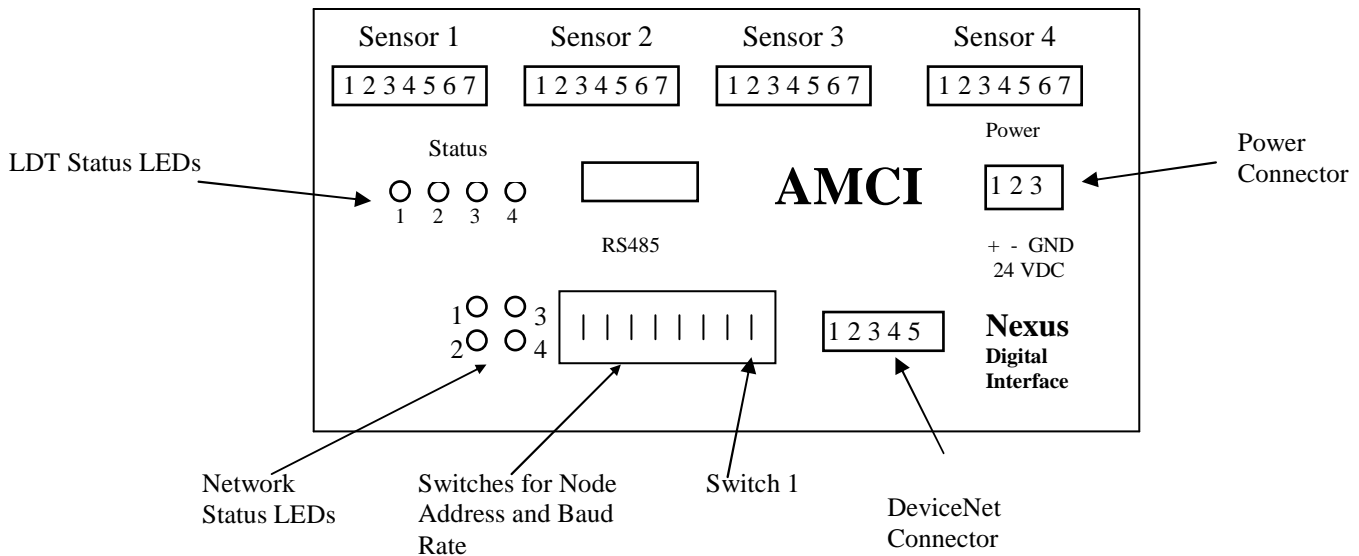

DeviceNet Connector

The 5 pin DeviceNet Connector has the following wiring.

Pin Number	Function	Standard Wire Color
1	+24Vdc	Red
2	Can High	White
3	Shields	Bare
4	Can Low	Blue
5	Common	Black

Node Address and Baud Rate Selection

The NX2C4D uses eight DIP switches to select the Node Address and the Baud Rate. Switches 1 and 2 set the Baud rate and switches 3 to 8 set the node, with switch 8 being the least significant bit. The following table shows the possible switch setting combinations.

The DIP switch package is mounted so that the numbers are upside down. However, “1” or “ON” is still in the up position and “0” or “OFF” is in the down position.

Baud Rate	Switches 1 & 2
125k	0 0
250k	0 1
500k	1 0
Reserved	1 1

Node Address	Switches 3 to 8
0	0 0 0 0 0 0
1	0 0 0 0 0 1
2	0 0 0 0 1 0
61	1 1 1 1 0 1
62	1 1 1 1 1 0
63	1 1 1 1 1 1

Example: For a Baud Rate = 250K and the Node Address = 5, switches 2, 6, and 8 would be ON, up towards the top of the module and switches 2, 3, 4, 5, and 7 would be OFF, down towards the bottom of the module.

Note: The state of the switch settings is only taken into account at power up.

DeviceNet Status LEDs

The following table describes the function of the four network status LEDs.

LED Number	Name	LED Pattern	Description
1	Module Network Status	Steady Off Steady Red Steady Green Flashing Red	No Power Unrecoverable Fault Device Operational Minor Fault
2	Network Status	Steady Off Steady Red Steady Green Flashing Red Flashing Green	Not Powered / Not On Line Critical link failure Link OK, On Line, Connected Connection Time Out On Line not connected
3	Reserved		
4	Reserved		

Adding the NX2C4D to your network

Before the NX2C4D can be attached to a network, it must be added to the RSNetWorx for DeviceNet software. The EDS and icon files are available in the *Driver File Download* section of our website, www.amci.com. The following procedure to add the EDS file to RSNetWorx assumes that you have already downloaded these files and un-zipped them.

1. With the power off, use the dip switches on the front of the NX2C4D to set the node address and the baud rate.
2. Start RSNetWorx for DeviceNet.
3. In the RSNetWorx program, click on **Tools** in the menu bar.
4. Click on **EDS Wizard...** from the pull down menu that appears.
5. Click on **Next>** in the window that appears.
6. Select **Register an EDS file(s)** and click on **Next>**.
7. Select **Register and EDS file**.
8. Click on **Choose File...** and navigate to the folder where you placed the un-zipped EDS and icon files.
9. Double click on **NX2C4D_r01.eds** file.
10. Click on **Next>**.
11. Click on **NX2C4D_r01.eds** file so that it is highlighted.
12. Click on **Next>** to assign an icon to the device.
13. Click on the NX2C4D and then click on **Change icon...** to select the icon for the Nexus unit. You can choose one of the built in icons from Rockwell Automation or click on the **Browse...** button and select the **NX2C4D_r01.ico** icon file.
14. Click on **Next>** and then click on **Finish** to complete the installation of the AMCI NX2C4D EDS file to the RSNetWorx system.

Once the EDS file is added to your system, add the NX2C4D to your network as you would any other device, including adding it to the scanlist configuration of the scanner module.

NX2C4E Ethernet Hardware Overview

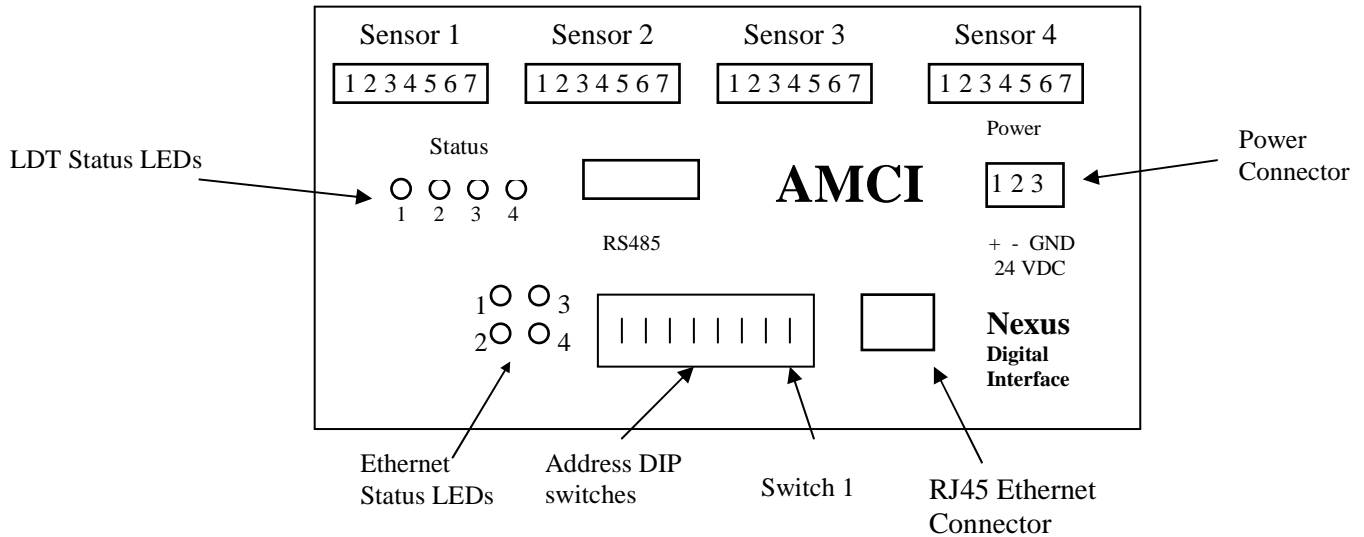

Network Update Time

Both the NX2C4C and the NX2C4C-08 both have a minimum network update time of 3ms.

Ethernet IP Address

The NX2C4E uses has a default IP address of 192.168.000.XXX where “XXX” can be any number between 1 and 254.

Every Ethernet IP unit, including those made by AMCI, has a unique MAC ID number. This number is located directly below the label on the side of the unit and identifies the unit to the Ethernet Network.

You can download the BOOTP software from Allen-Bradley's website. This BOOTP software uses the MAC ID address and allows you to change the unit's IP address. After changing the IP address, you must cycle power to the NX2C4E to make the changes to the IP address take affect.

The DIP switches will no longer have any function after you have changed the IP address.

Ethernet Address Selection using the DIP switches

The NX2C4E uses an IP address of 192.168.000.XXX where “XXX” can be any number between 1 and 254. Eight dip switches on the NX2C4C are used to set the “XXX” portion of the address. Switch 8, the left most switch, is the least significant bit and switch 1, the right most switch, is the most significant bit. The address is programmed using the following procedure.

1. Determine the address of the NX2C4E. It can be any unused address between 1 and 254.
2. Convert the address to a binary number. A value of 50 will be 0011 0010.
3. Enter the address on the dip switches. Continuing the above example, switches 8, 6, 5, 2 and 1 will be off (down) and switches 7, 4, and 3 will be on (up).

Ethernet Status LEDs

LED Number	Name	LED Pattern	Function
1	Network Status	Steady Off Steady Green Flashing Green Flashing Red Steady Red Flashing Green/Red	The module has no power or an IP address has been assigned. The module has at least one established Ethernet/IP connection. There are no Ethernet/IP connections established to the module One or more of the connections in which this module is the target has timed out The module has detected that its IP address is already in use The module is performing a power on self test
2	Module Status	Steady Off Steady Green Flashing Green Flashing Red Steady Red Flashing Green/Red	No Power. The module is operating correctly. The module has not been initialized. A minor recoverable fault has been detected. A major internal error has been detected. The module is performing a power on self test.
3	Activity LED		This LED flashes green each time a packet is received or transmitted
4	Link		This LED indicates that the module is connected to an Ethernet network

Setup Example

AMCI NX2C4E to Rockwell Automation 1756-ENET/B module

1. With power removed, use the dip switches to set the address of the NX2C4C.
2. Open an existing or create a new ControlLogix program.
3. From the project tree, right click on I/O configuration and select New Module.
4. From the Module Type list that appears, select 1756-ENET/B, the 1756 Ethernet Bridge module.
5. Type a name for the Bridge module, which must begin with a letter, in the Name field.
6. Enter the slot number where the 1756-ENET/B module is located in the ControlLogix rack.
7. In the Address/Host Name field, select the IP Address enter the desired address, for example, 192.168.000.XXX where XXX can be a unique number between 1 and 254.
8. Click the Finish button.
9. From the project tree, right click on the 1756-ENET/B module and select New Module.
10. Select ETHERNET-MODULE Generic Ethernet Module from the list that appears and click on OK.
11. In the module properties that appear, enter the following parameters.

Name: **Your Choice** (must begin with a letter)

Comm Format: **Data-INT (must be Data-INT)**

IP Address: **192.168.000.XXX** where XXX is the number entered on the DIP switches

Assembly Instance – 100, Input – 20 for the NX2C4E
136 for the NX2C4E-08

Assembly Instance – 150, Output – 33 for the NX2C4E
33 for the NX2C4E-08

Assembly Instance – 110, Config – 0 for all versions of the Nexus LDT Interface

12. Click on Next.

13. Select the RPI time, minimum = 3ms
 14. Click on Finish.
 15. Save and download the program to the ControlLogix rack.
 16. While online with the PLC, right click on the Ethernet Bridge module and select Properties.
- Click on the Port Configuration tab and modify the following fields.

Enable Bootp: **Unselected** (This will allow the data to be manually entered in the IP address and Domain Name fields.)

IP Address: **192.168.000.XXX** (must be the same as step 7 above)

Subnet Mask: **255.255.255.0**

The Gateway Address, Domain Name, Primary DNS Server Address, and Secondary DNS Server Addresses all remain unchanged.

NX2C4P Profibus Hardware Overview

Because Profibus does not support the transfer of 136 output words, a Profibus version of the Multiple Magnet Nexus unit, the NX2C4P-08, does not exist.

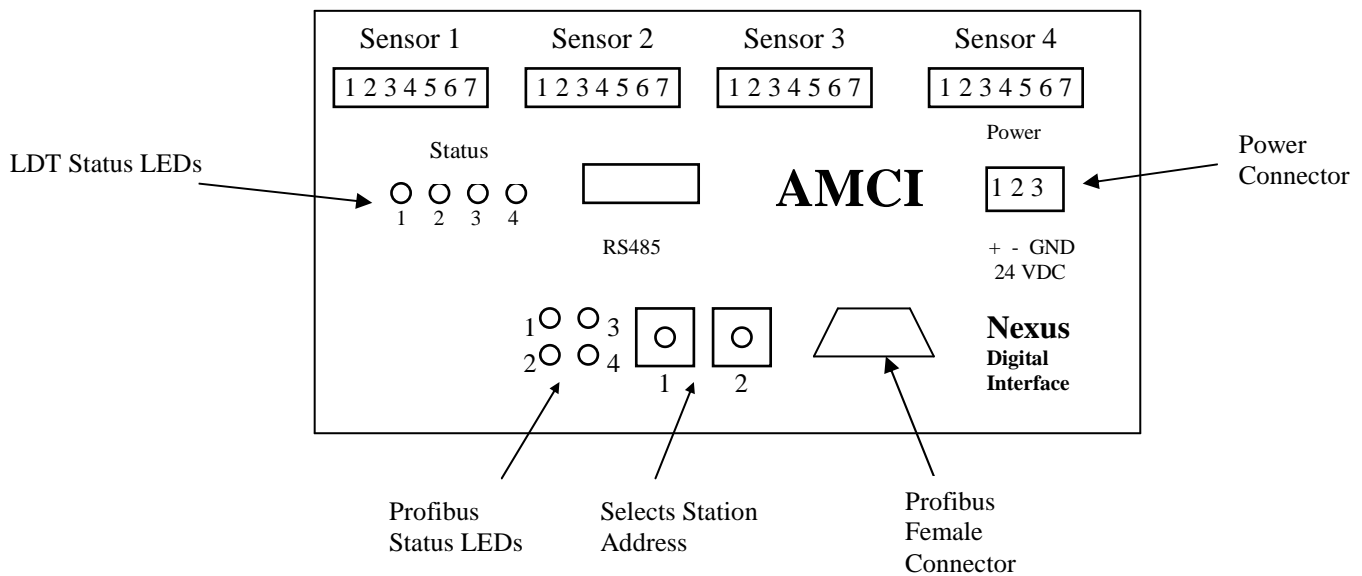

Profibus Connector

The Nexus module uses a 9 pin female D-sub connector to communicate with the Profibus network.

Station Address Selection

The Nexus module has two rotary switches used to set the module's address on the network. Any station from 0 to 99 can be selected. Switch 1 sets the one digit and switch 2 sets the 10s digit of the address. For example, if the Nexus is to be installed at station 46, switch 1 would be set to 6, and switch 2 would be set to 4. Note, changing the station address only takes affect at power up. Changing the address while power is applied to the Nexus module will generate a minor fault.

Profibus Status LEDs

LED Number	LED Pattern	Function
1	Red Off	Module is Offline and no data exchange is possible The module is Online
2	Green Off	Module is Online and data exchange is possible The module is Off line
3	Flashing Red 1Hz Flashing Red 2Hz Flashing Red 4Hz Off	Error in configuration: IN and/or OUT length set during initialization of the module is not equal to the length set during the configuration of the network Error in User Parameter data: The length/contents of the user parameter data set during initialization of the module is not equal to the length/contents set during configuration of the network. Error in initialization of the Profibus communication ASIC. No diagnostic present
4	Off	Not Used

Network Baud Rate

The NX1F2P supports the following network baud rates

9.6 kbits/sec, 19.2 kbits/sec, 93.75 kbits/sec, 187.5 kbits/sec, 500 kbits/sec, 1.5 Mbits/sec, 3 Mbits/sec, 6 Mbits/sec, and 12 Mbits/sec

Quick Start Guide

AMCI Nexus to SST-PFB-SLC Profibus interface module

1. If it is not already present, install the SST-PFB-SLC module in the SLC rack and configure the rack (the ID code is 13635) for the module.
2. Place the PLC in program mode.
3. Connect a serial cable from the computer's COM port to the RS232 port of the SST-PFB-SLC module.
4. With the power off, use the rotary switches on the Nexus unit to select the desired station address. The left switch sets the 1s digit and the right switch sets the 10s digit of the station address.
5. Attach the Nexus unit to the Profibus network.
6. Apply power to the Nexus unit.
7. Start the SST Profibus Configuration software. (Current Version 1.9)
8. Either create a new or open an existing network.

9. If it has not already present, register the Nexus units GSD file.

Click on Library in the toolbar and then select Add GSD file. Choose the directory where the GSD file is located, and then select the AnyBPRfB file.

When registered this module will appear under Slaves as:

HMS Fieldbus Systems AB
ANYBUS-S PDP

10. If SST-PBF-SLC module is not already present, click on Masters. Click and drag the Master (Rev 1.4) into the network. Right click on it and configure it according to your system's requirements.
11. Under slaves, click and drag the ANYBUS-S PDP module into the network. The setup window will appear.
- Under the **General** tab, set the station number to match the station number set by the rotary switches on the Nexus unit.
 - Click on the **Modules** tab and then click on Add. The NX2C4X must be set for 28 input words and 33 output words. If a different number of words is programmed, Network LED 3 will flash indicating an Error in the Configuration. The input words can be located in either the Input Image table or in the M1 file, however, all 28 input words must be located in one file. The 33 output words must be located in the MO file.
 - Click on Input 32 Byte (16 word) and then on OK.
 - Click on the **SLC Address** tab and then select the Input Type, either I or M1, and the offset value, that is where in the I or M1 table the data begins. It is important not to leave gaps between an existing Profibus module and the data used by the Nexus unit.
 - Again click on the **Modules** tab and click on Add.
 - Click on Input 16 Byte (8 word) and then on OK.
 - Click on the SLC Address tab and then select the Input Type to be the same as was selected above. Set the offset value to the value assigned to the 32 byte parameter plus 16.
 - Again click on the **Modules** tab and click on Add.
 - Click on Input 8 Byte (4 word) and then on OK.
 - Click on the **SLC Address** tab and then select the Input Type to be the same as was selected above. Set the offset value to the value assigned to the 16 byte value plus 8.
 - Again click on the **Modules** tab and click on Add.
 - Click on Output 64 Byte (32 word) and then on OK.
 - Click on the **SLC Address** tab and then select the Output Type to be M0 and then select an offset value. As with the input data, it is important not to leave gaps between an existing Profibus module and the data used by the Nexus unit.
 - Again click on the **Modules** tab and click on Add.
 - Click on Output 2 Byte (1 word) and then on OK.
 - Click on the **SLC Address** tab and then select the Output Type to be MO. Set the offset value assigned to the 64 byte value plus 32.
 - Click on OK to accept.
12. Save the network file.
13. Right click on the Master Module and select Connect from the menu that appears.

14. Click on Yes if asked to retain the configuration.
15. Again right click on the Master Module and then select Load Configuration from the menu that appears.
16. Place the PLC in Run mode.

NX2C4T (Modbus TCP IP) Hardware Overview

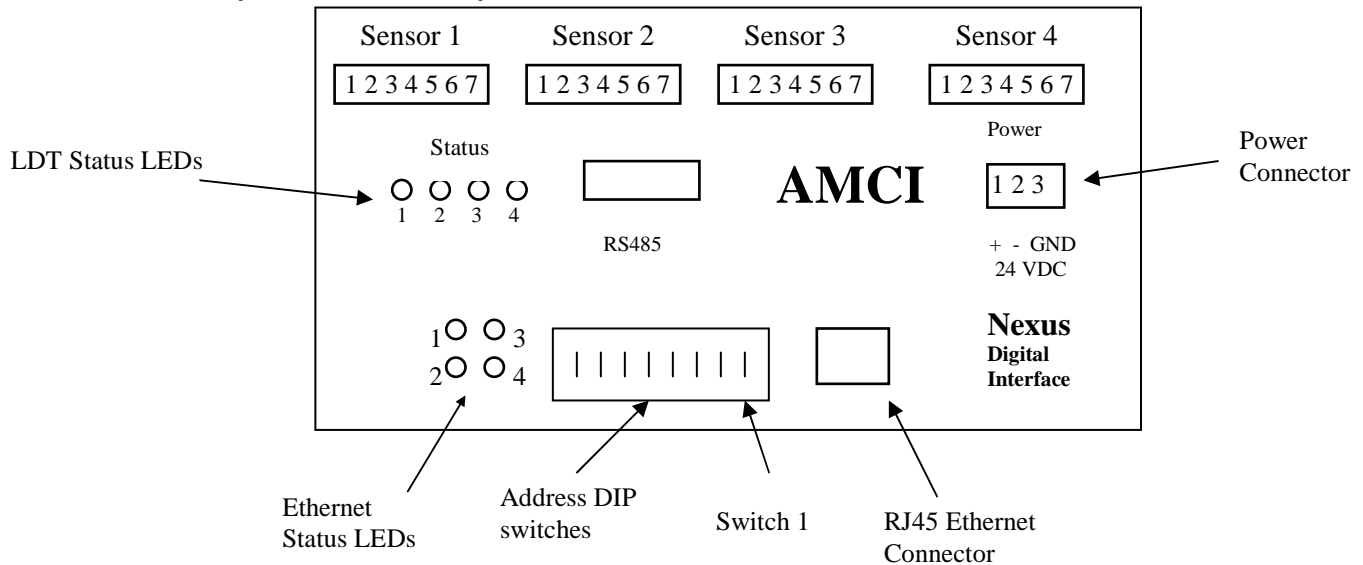

Changing the Modbus TCP/IP Address

The NX2C4T has a default IP address of 192.168.000.XXX where “XXX” can be any number between 1 and 254 and is set by the dip switches located on the front of the module.

Use the following procedure if you want your IP address to be something other than 192.168.000.XXX.

1. Remove power from the Nexus Unit.
2. Set all of the unit’s dip switches to the OFF (Down) position. This will set the unit’s address to 0000 0000.
3. Start and configure your BootP server. Any DHCP/BootP server running on a computer, which is connected to the same network, may be used for this purpose. Please note that the Nexus Unit’s MAC ID address is located on a label on the module’s cover.
4. Apply power to the Nexus Unit.
5. At power-up the module will attempt to get an IP address by sending several BootP requests. This operation will require approximately 30 seconds. At this point LED2 will be flashing green. If retrieved, the IP configuration will be used and stored in the Nexus Unit’s Flash Memory, overwriting older IP settings.
6. The Nexus Unit will now join the network with the newly set IP configuration.
7. If a BootP server is not found, the Nexus Unit will use the IP configuration that had been previously stored in its flash memory.
8. Cycle power to the NX2C4T. The changes to the IP address will not be permanent until power has been cycle.

Modbus TCP/IP Address Selection using the DIP switches

The NX2C4T uses an IP address of 192.168.000.XXX where “XXX” can be any number between 1 and 254. Eight dip switches on the NX3A1X are used to set the “XXX” portion of the address. Switch 8, the left most switch, is the least significant bit and switch 1, the right most switch, is the most significant bit. The address is programmed using the following procedure.

1. Determine the address of the NX2C4T. It can be any unused address between 1 and 254.
2. Convert the address to a binary number. A value of 50 will be 0011 0010.
3. Enter the address on the dip switches. Continuing the above example, switches 8, 6, 5, 2 and 1 will be off (down) and switches 7, 4, and 3 will be on (up).



Modbus TCP/IP Ethernet Status LEDs

LED Number	Name	LED Pattern	Function
1	Network Status	Flashing Green with 2 seconds interval	This LED indicates the number of established Modbus/TCP connections to the module. The number of connections is equal to the number of flashes on this LED.
		Flashing Green/Red	Power-on self test
2	Module Status	Steady Off	No Power
		Steady Green	The module is operating correctly
		Flashing Green	The module has not been initialized
		Flashing Red	Minor recoverable fault
		Steady Red	Major internal error
		Flashing Green/Red	Power-on self test
3	Activity	Flashing Green	This LED flashes green each time a packet is received or transmitted
4	Link	Steady Green	This LED indicates that the module is connected to an Ethernet network

Setup Example

AMCI NX2C4T to Group Schneider’s 140 NOE 771 01 module

This setup example assumes that the 140 NOE 771 01 module has already been installed in the PLC system.

1. With power removed, use the dip switches to set the IP address of the NX2C4T.
2. Open an existing or create a new Unity program.
3. Open the Project Browser and click on the  symbol next to Communication.
4. Click on the  symbol next to Networks to show the available networks.
5. If you are creating a new network for the NX2C4T, right click on Networks and select New Network from the window that appears. If you are adding the NX2C4T to an existing network, ignore this step.

Click on the down arrow to the right of the *List of available Networks* field and select *Ethernet* from the drop down menu that appears.

Type the new networks name in the Change Name field

Click on OK to create the new network.

- Right click on the existing network and select open from the window that appears. The following window will appear.

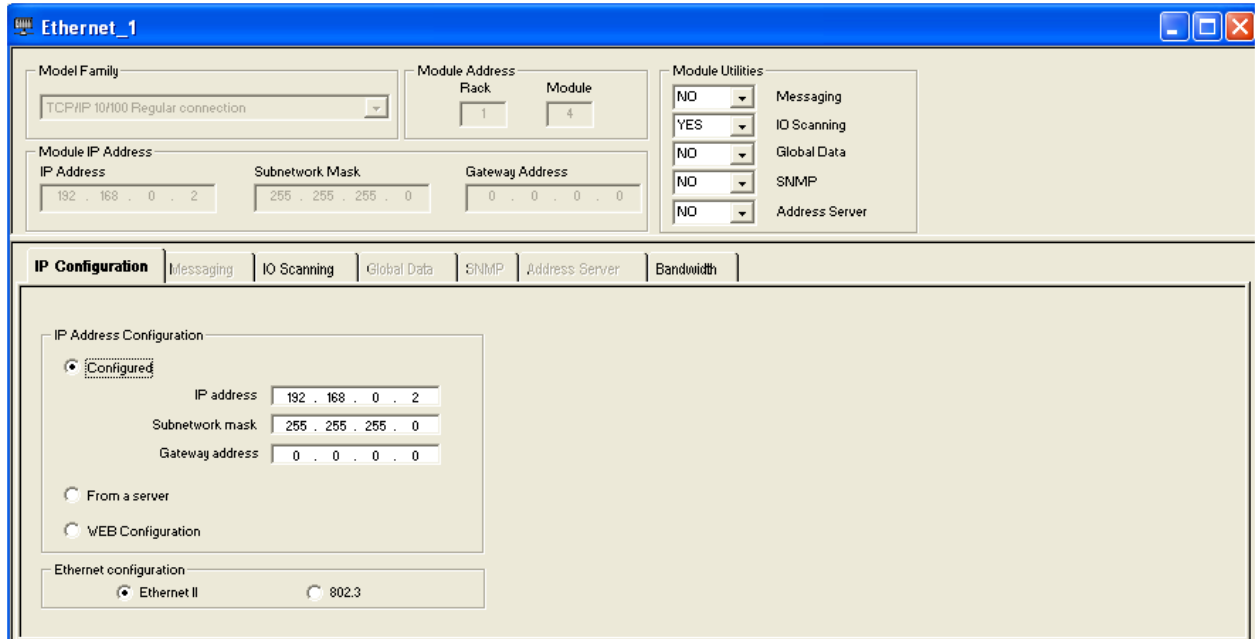

- Enter the following parameters.



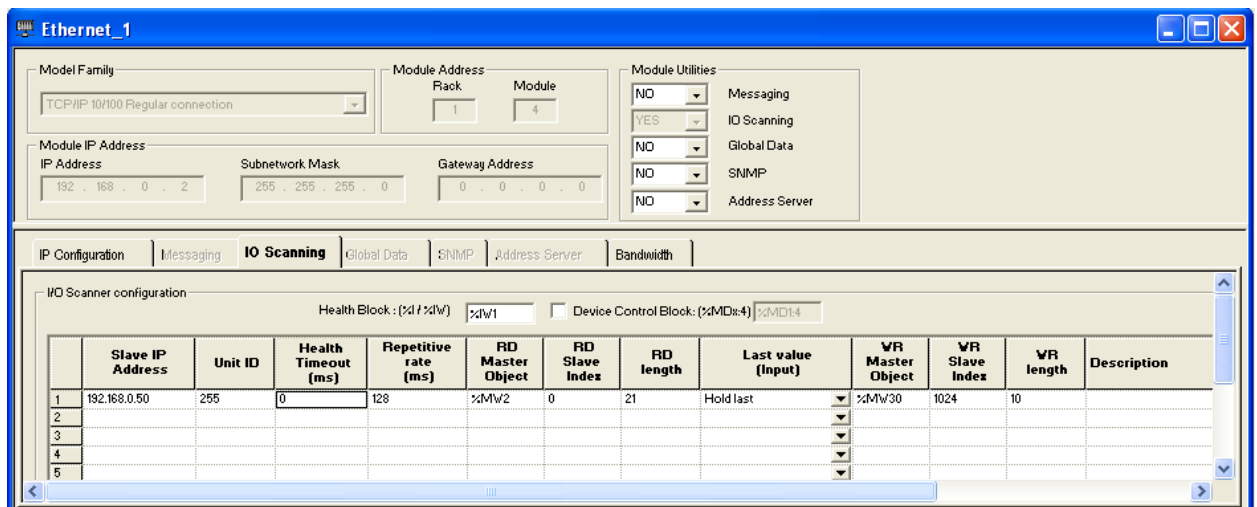

Module Family: TCP/IP 10/100 Regular Connection
 Module Address: Location of the 140 NOE 771 01 module
 IP Address: The TCP/IP address of the 140 NOE 771 01 module
 Subnet Mask: 255.255.255.000

- Click on the I/O scanning tab. The following screen will appear.



Enter the following parameters.

Slave IP Address:	IP Address of the NX2C4T module.
Unit ID:	Not necessary for the NX2C4T module. The default value of 255 can remain.
Health Timeout:	Timeout value measured in ms. Can be any value for the NX2C4T module
Repetitive Rate:	Update time of the NX2C4T in ms. A value of zero will result in the fastest transfer of data between the NX2C4T and the NOE module. A value other than zero must be in a multiple of 16.
RD Master Object.	First destination address register where the data transmitted from the NX2C4T will be located.
RD Slave Index:	Must be 0.
RD Length:	Set to 28 for the NX2C4T or 136 for the NX2C4T-08 (sixteen bit words)
Last Value (input):	Status of the input registers, either last state or zero, in the event of an error. The data from the NX2C4T will remain in the registers if communications are lost.
WR Master Object:	First source address register location where the data sent from the PLC to the NX2C4T is located.
WR Slave Index:	<u>Must</u> be set to 1024
WR Length:	<u>Must</u> be set to 33 (The NX2C4T uses thirty three 16 bit output words)
Description:	Your choice of text or leave blank.

9. Close the network.
10. Click on Yes when asked "Do you want to save your modifications?"
11. Click on Yes when asked "Do you Confirm the Modification?"
12. On the Project Tree, expand the I/O configuration by clicking on the  symbol to the left of Configuration.
13. Further expand the I/O configuration by clicking on  symbol to the left of the Local Bus.
14. Continue to expand the I/O configuration by clicking on the  symbol to the left of the Local Quantum Drop.
15. Continue to expand the I/O configuration by clicking on  symbol to the left of the rack that contains the 140 NOE 771 01 module.
16. Expand the networks attached to the NOE module by clicking on the  symbol to the left of the 140 NOE 771 01 module.
17. Right click on the network associated with the 140 NOE 771 01 module and select OPEN from the window that appears.
18. Click on the down arrow on the field just below where it asks you to "Please choose a Network." Select the network that was created above.
19. Save and build the project, and download it to the PLC. If the NX2C4T is powered up and attached to the network, network LED 3 (the upper right network status LED) should now be flashing and network LED 4 (the lower right network status LED) should now be on solid.

Chapter 7: Manual Revision History

Version 1.0 added details to the specifications and a more complete hardware description.

Version 1.1 added the update time of the NX2C4X-08 and updated the ControlNet setup procedures.

Version 1.2 changed the SSI update time to 500 μ s (this change was made for the V1 firmware) and added a note on how programming the channel and applying the preset value on a NX2C4X and a NX2C4X-08 at the same time will cause a command error.

Version 1.3 was released on 12/6/01 and added a column to the input data tables. One column shows that the PLC-5 input data starts at word 0 and a second shows that the ControlLogix input data starts at word 2.

Version 1.4 was released on 3/18/02. Dimensions were added. The references to the RSLogix revisions were removed from the quickstart guide.

Version 1.5 was released on 10/15/02. A note was added that the Nexus unit interfaces with sensors whose output signals are at 5Vdc, regardless of the sensor's power supply.

Version 1.6 was released on 4/28/05. This version added a note to the functionality of ControlNet LED 3.

Version 1.7 was released on 5/11/05. This version removed the SSI functionality, and added the DeviceNet, Ethernet, and Profibus networks to the specifications. The Hardware overview and wiring as also moved to the beginning of the specifications. Notes were added that because of the number of words used, the NX2C4D-08 and the NX2C4P-08 are not available.

Version 1.8 was released on 7/23/07. This version added mounting information and increased the number of input words from 20 to 28. This was changed for the NX2C4P unit. Existing customers with NX2C4C and NX2C4E units can still set the number of input words to 22 and 20 respectively.

Version 1.9 was released on 6/9/10. This revision added outline drawings, specifications, programmable parameters, and using the Modbus TCP/IP to the specifications.

File: Nexus_LDT_specifications.doc
date: 6/9/10