

3401L ADDENDUM

This document is an addendum to the 3401 manual revision 1. It lists the differences between the 3401 that has differential driver outputs, and the 3401L that has single ended outputs. Wiring diagrams for the 3401L are also provided.

Changes between the 3401 and the 3401L

The 3401 and 3401L are functionally identical. Network configurations and programming are exactly the same. A programmer will see no differences between the two controllers.

The 3401 has high speed differential outputs while the 3401L has higher power, single ended, sinking outputs.

- ▶ Maximum output frequency of the 3401 is 1MHz. Maximum output frequency of the 3401L is 200KHz. This 200KHz limit is not programmed into the 3401L, but is based on factory design testing. You can program the 3401L to output pulses at a 1MHz rate, but the outputs will be distorted.
- ▶ The 3401 can drive a 5Vdc differential output up to 20mA. The 3401L can drive a single ended output up to 24Vdc at 30mA.

The pin out of the Removable Terminal Block (RTB) is slightly different due to the change from differential to single ended outputs. However, if you are switching from a 3401 to a 3401L, you can use the same four wire cable between the 3401L and the driver. You must change how it is wired, but the same cable can be used.

Maximum Output Frequency

As stated above, the maximum recommended output frequency for the 3401L is 200KHz. This frequency is based on testing done at AMCI using a variety of loads including an HCPL0603 opto-isolator with a 3Kohm current limiting resistor.

Like the 3401, the 3401L can be programmed to output pulses to 1MHz. However, at this rate, the motor driver will most likely miss pulses from the 3401L. A motor running rough during a move and a loss of positional accuracy are the two signs of a motor driver missing pulses from the 3401L.

Wiring Changes

The figure below shows the differences in RTB pin out between the 3401 and the 3401L.

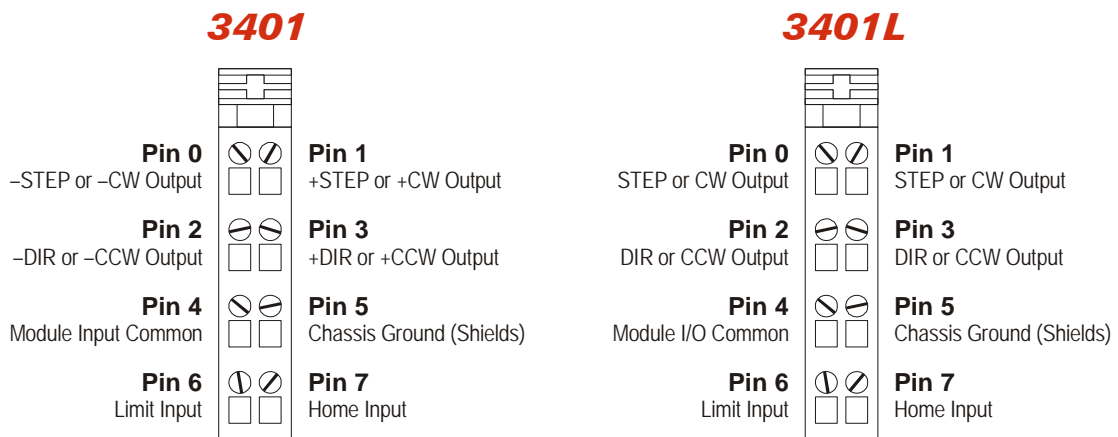

NOTE

Pins 0 & 1 are electrically connected
Pins 2 & 3 are electrically connected
You can wire to either pin in these two sets

Wiring Changes (continued)

The following figures show how to wire the single ended outputs of the 3401L to sourcing and sinking inputs.

3401L Connection to Sourcing Inputs

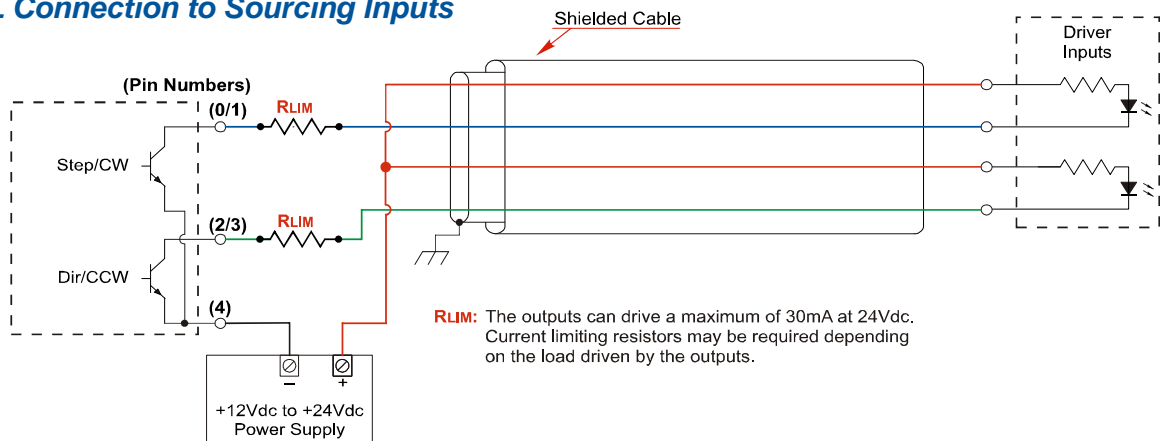

3401L Connection to Sourcing Inputs

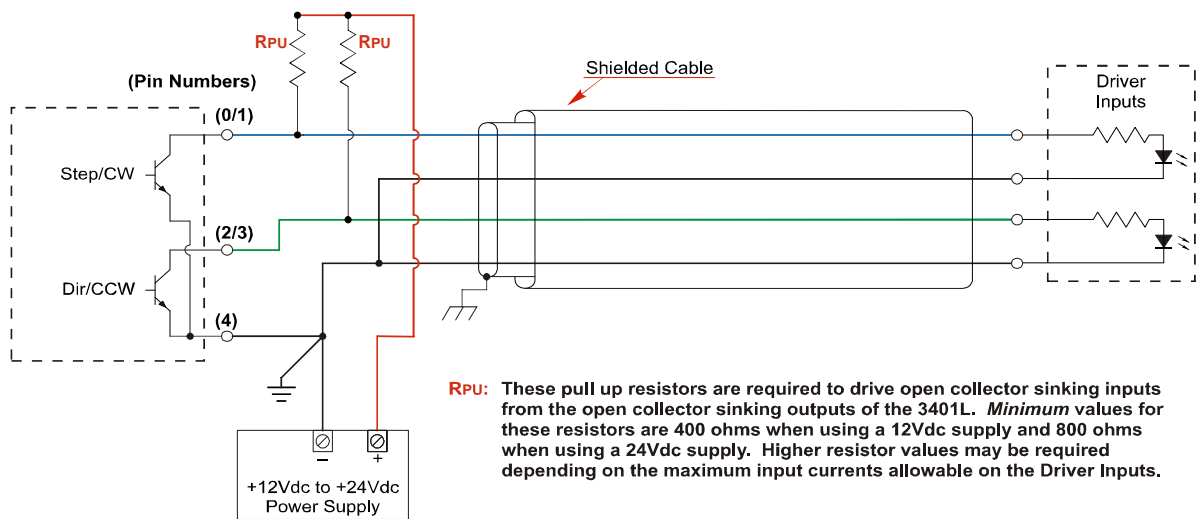

NOTE ⚠ These diagrams show connections through a four wire cable. (A four wire cable *must* be used with the 3401L.) It is also possible to use a three wire cable with a 3401L by using only one wire to carry the common connection of the two inputs instead of two separate wires.