Module Overview

The 7262 module is a two-channel SSI interface module that resides in a Rockwell Automation ControlLogix rack.

This module is capable of connecting up to two independent SSI output encoders/sensors with max 32-bit resolution for position. This module also has two latching inputs, one for each channel, which can be used to capture the sensor's data.

The 7262 module communicates with the PLC using input and output registers. The Data value, Velocity, Latched Value, and Status information are reported to the Input Registers. All module setup parameters, including Preset Value, Count Direction, Velocity Response Time, as well as the Sensor Logic parameters [Data Type (binary/gray), Data Logic (positive/negative), Number of Data Bits and Clock Frequency] are programmed through Message Instructions.

The Output registers assigned to the module can be used to Apply the Preset or to send the PLC's *Central System Clock-Time* to the 7262 module. This optional and additional feature causes the module to use this system time and the sensors velocity data to calculate an Interpolated or "Look Ahead" Data value.

The 7262 module stores its parameters in a non-volatile flash memory when power is removed so it is not necessary to program the module at every power up. However, this flash memory is good for a minimum of 10,000 write cycles, so the module must not be programmed during every machine cycle.

The module has two opto-coupler latching inputs that will capture the scaled sensor data on the rising, falling, or both transitions of the input. These inputs can be wired to be sinking or sourcing and will activate when they see a voltage level between 8 and 24Vdc across the + and – latch terminals.

Through the use of different rack Assembly Instances, the 7262 can be configured to operate with one or two of the available channels. Disabling the unused channel is recommended for improving the throughput time.

General Information

Important User Information

The products and application data described in this manual are useful in a wide variety of different applications. Therefore, the user and others responsible for applying these products described herein are responsible for determining the acceptability for each application. While efforts have been made to provide accurate information within this manual, AMCI assumes no responsibility for the application or the completeness of the information contained herein. Throughout this manual the following two notices are used to highlight important points.

WARNINGS tell you when people may be hurt or equipment may be damaged if the procedure is not followed properly.

CAUTIONS tell you when equipment may be damaged if the procedure is not followed properly. No patent liability is assumed by AMCI, with respect to use of information, circuits, equipment, or software described in this manual. The information contained within this manual is subject to change without notice. **UNDER NO CIRCUMSTANCES WILL ADVANCED MICRO CONTROLS, INC. BE RESPONSIBLE OR LIABLE FOR ANY DAMAGES OR LOSSES, INCLUDING INDIRECT OR CONSEQUENTIAL DAMAGES OR LOSSES, ARISING FROM THE USE OF ANY INFORMATION CONTAINED WITHIN THIS MANUAL, OR THE USE OF ANY PRODUCTS OR SERVICES REFERENCED HEREIN.**

Standard Warranty

ADVANCED MICRO CONTROLS, INC. warrants that all equipment manufactured by it will be free from defects, under normal use, in materials and workmanship for a period of [18] months. Within this warranty period, AMCI shall, at its option, repair or replace, free of charge, any equipment covered by this warranty which is returned, shipping charges prepaid, within one year from date of invoice, and which upon examination proves to be defective in material or workmanship and not caused by accident, misuse, neglect, alteration, improper installation or improper testing. The provisions of the "STANDARD WARRANTY" are the sole obligations of AMCI and excludes all other warranties expressed or implied. In no event shall AMCI be liable for incidental or consequential damages or for delay in performance of this warranty.

Returns Policy

All equipment being returned to AMCI for repair or replacement, regardless of warranty status, must have a Return Merchandise Authorization number issued by AMCI. Call (860) 585-1254 with the model and serial numbers along with a description of the problem. A "RMA" number will be issued. Equipment must be shipped to AMCI with transportation charges prepaid. Title and risk of loss or damage remains with the customer until shipment is received by AMCI.

24 Hour Technical Support Number

Technical Support, in the form of documents, FAQs, and sample programs, is available from our website, www.amci.com. 24 Hour technical support is also available on this product. For technical support, call (860) 585-1254. Your call will be answered at the factory during regular business hours, Monday through Friday, 8AM - 5PM EST. During non-business hours, an automated system will ask you to leave a detailed message and the telephone number that you can be reached at. The system will page an engineer on call. Please have your product model number and a description of the problem ready before you call.

Table of Contents

Installing the 7262 Module	Chapter 1	4
Hardware Overview	Chapter 2	5
	Module Specifications	5
	Front Panel & LED Function	6
	Connector Pinout	6
	Wiring Notes	7
	Latching Input Wiring	8
	SSI Protocol	8
Programmable Parameters	Chapter 3	9
	Module Setup Parameters	9
	Latched Input	9
	Interpolated Position	9
	Limit Switch Position	10
	SSI Setup Parameters	10
	SSI Clock Frequency	10
	Number of SSI Data bits	10
	Most Significant Bit Number	10
	Number of SSI Clock Bits	10
	Data Type	10
	Data Logic	10
	Data Setup Parameters	11
	Scalar Multiplier & Divisor	11
	Determining Multiplier & Divisor	11
	Preset Value	12
	Apply Preset	12
	Count Direction	12
	Velocity Update Time	12
Message Instructions	Chapter 4	13
	Configuration Tab	13
	Writing Data Setup	14
	Reading Data Setup	14
	Communication Tab	15
	Extended Error Codes	15
Setup Data	Chapter 5	16
Reading Status Data	Chapter 6	17
Input & Output Data	Chapter 7	18
	Input Registers	18
	Status Bits	19
	Input Register Description	19
	Output Registers	20
	Command Bits	20
	Apply Preset Programming Cycle	20
	Interpolation Command Programming Cycle	21
Specification Revision History	Chapter 8	21

Chapter 1: INSTALLING THE 7262 MODULE

Configuring the ControlLogix System

1. Open RSLogix 5000 and the project in which you want to install the AMCI 7262 module.
2. Right click on I/O Configuration in the Project Tree.
3. Select New Module.
4. Select the following module type and description from the list that appears.

Type = 1756-MODULE
 Description = Generic 1756 Module

5. Click on OK.
6. Enter the following module properties.

Name: *Your Choice* (must begin with a letter)
Description: *Your Choice*
Comm Format: *Data-DINT* (must be Data-DINT)
Slot: *location of 7262 module*

7. Enter the Connection Parameters from the following table. Please note that the 7262 module can be configured in two ways, depending on how many channels are being used. Disabling the unused channel is recommended because the module will stop all activities associated with the unused channel, which will improve the throughput time.

Owner Controller			Listen Only	
Parameter	Assembly Instance	Size in 32 bit words	Assembly Instance	Size in 32 bit words
1 Channel				
INPUT	101	6	101	6
OUTPUT	111	2	115	1
CONFIGURATION	1	0	5	0
2 Channels				
INPUT	102	12	102	12
OUTPUT	112	4	115	1
CONFIGURATION	2	0	5	0

The Owner Controller setup will be used in most instances. The Listen Only setup should only be used by the listening processor(s) in systems with more than one PLC. Please note that the RPI time of the Listen Only processor must be greater than or equal to the RPI of the Owner Controller, and the number of channels on the Listen Only processor must match the number of channels on the Owner Controller.

8. Click on Next >
9. Set the RPI (Rate Packet Interval) Time to the desired value. For the 7262 module, the RPI parameter has a range of 0.5 to 28ms, with a recommended RPI time of 5ms.
10. Click on Finish >>

The module should now appear in the project tree. The Input data will be referenced as Local:X.I.Data[Y] and the output data will be referenced as Local:X.O.Data[Y] where “X” is the slot number and “Y” is the word number.

Chapter 2: HARDWARE OVERVIEW

Module Specifications

Current Draw: 400ma @ 5Vdc from PLC backplane

Throughput Time: 0.2ms to 1.2ms depending on the SSI frequency and the number of bits and channels used.

RPI Value: 0.5 to 28ms, with a recommended RPI time of 5ms.

External Power: The 7262 module requires the use of an external +24Vdc power supply that is used power the input isolation circuitry and can also be used to power sensors that operate on 24Vdc

Voltage Range = +24V dc ($\pm 20\%$)

Current Draw = 150mA. Add this amount to your SSI encoder's current draw when sizing your external 24Vdc power supply.

5Vdc supply The 7262 module also uses the external power supply to generate a 5Vdc user power supply that can be used to power encoders and or sensors that run on 5Vdc. This 5Vdc supply can supply a maximum of 500mA ($\pm 5\%$) of current.

Latching Inputs These opto-coupler input terminals accept up to 24VDC signal across pins 17-15, 18-16, The latching function is performed as programmed when power is applied/removed, OFF to ON and/or ON to OFF, to/from the input.

Voltage Range: 0 to 30Vdc

On State: 8 to 30Vdc

Off State: 0 to 2Vdc

Current Draw: 10mA @ 24Vdc

Can be wired to single ended sinking or sourcing sensors

The latching inputs must be on for between 0.2ms and 1.2ms, depending on the number of channels being used.

Environmental Conditions Operating Temperature: 0 to 60° C
Relative Humidity: 5 to 95% (non-condensing)
Storage Temperature: -40 to 85° C

EDS File An EDS file for the 7262 module can be downloaded from the Tech Library section of AMCI's website, www.amci.com.

FLASH Memory

The 7262 module's parameter values are stored in a non-volatile Flash memory. This memory type can store parameter values in the absence of power for over twenty years, but you can only write to it a limited number of times before it will be damaged. The Flash Memory used in the 7262 module is guaranteed for a minimum of 10,000 write cycles.

Front Panel:

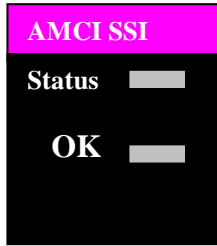

Status LED

<u>Solid Red</u>	Data Flash Memory Fault
<u>Blinking Red/Green</u>	Module Hardware Comm. Failure
<u>Blinking Red</u>	Output Data Fault
<u>Solid Green</u>	No motion occurring
<u>Blinking Green</u>	Motion on at least one channel

OK LED

<u>Solid Green:</u>	Module Owned, two-way communication
<u>Blinking Green:</u>	PLC in Program Mode or rack configuration not correct
<u>Blinking Red:</u>	Communication between module and PLC interrupted, as when a new program is downloaded to the PLC.

Connector Pin Out:

The input connector consists of a Removable Terminal Block with the Rockwell Automation Part Numbers 1756-TBCH (36 position cage clamp) or 1756-TBS6H (36 position spring clamp). The terminal block is not supplied with the 7262 module.

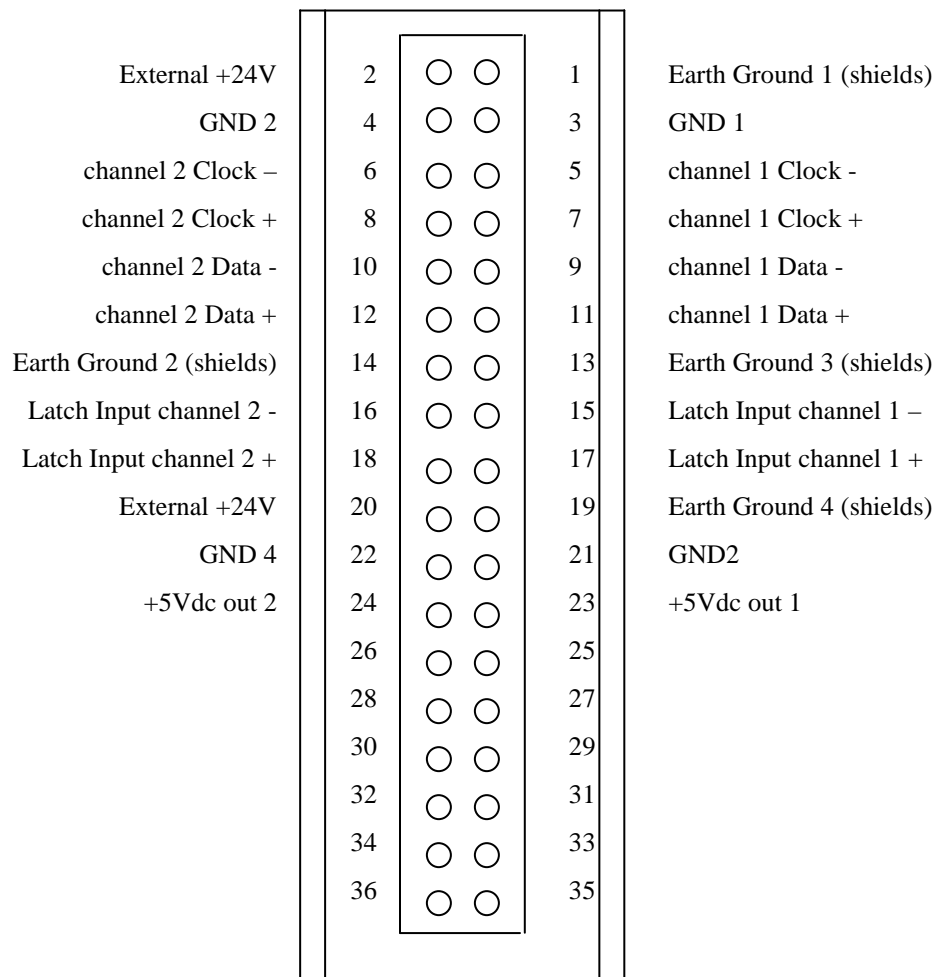

Wiring Notes

- Use the information provided by the encoder's manufacture to determine the type and maximum length of cable that should be used to connect the sensor to the 7262 module.
- When plugged into the 7262 module, pin 1 is located in the upper right hand corner.
- External +24Vdc (pins 2 and 20) are internally connected together.
- GND1/2/3/4 (pins 3, 4, 21 and 22) are internally connected together and must be connected to the external +24Vdc supply's common.
- The 7262 module uses the external +24Vdc supply to power the isolation circuitry and to generate +5Vdc user power (pins 23 and 24). These two pins, which are internally connected together, can be used to power sensors requiring less than 500 mA of current.

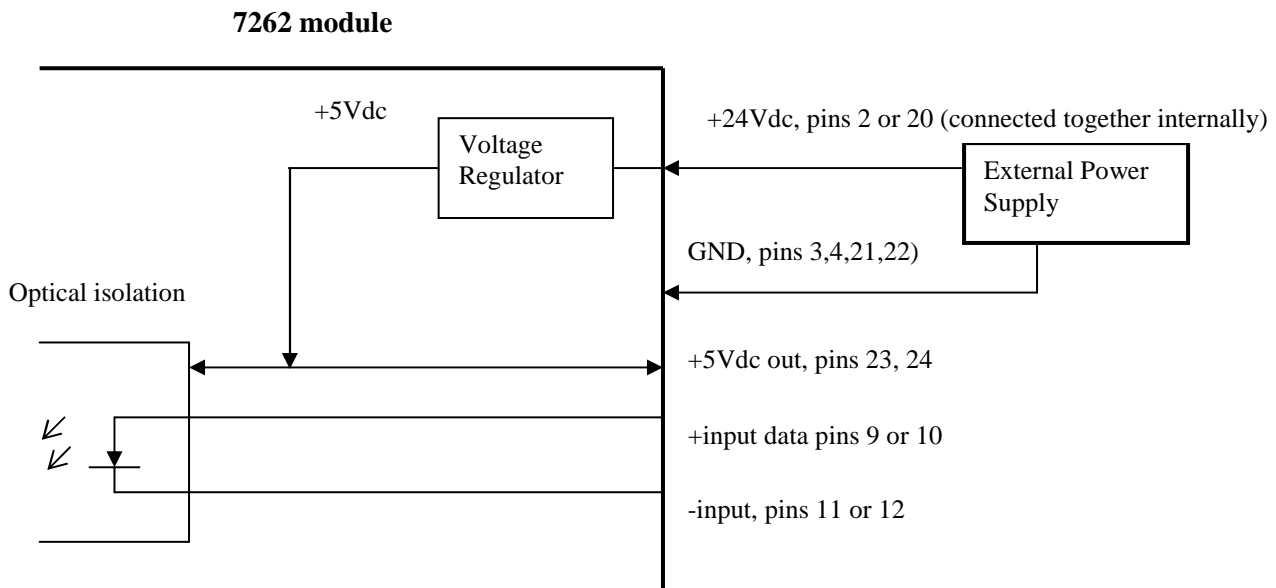

- Earth Grounds 1 through 4 (pins 1, 13, 14 and 19) are internally connected together and are connected to the ControlLogix rack structure. The cable shields of the sensor's cable should be connected to these terminals.
- Transducer signals are generally low voltage, low power signals. If you are using A-B guidelines for cabling installation, treat the transducer cable as a Category 2 cable. It can be installed in conduit along with other low power cabling such as communication cables and low power ac/dc I/O lines. It cannot be installed in conduit with ac power lines or high power ac/dc I/O lines.
- Like all signal and communication cable, the transducer cable should be shielded. These shields must be grounded only at one end of the cable. Because the rack cabinet is typically better grounded than the machine, AMCI recommends that the cable shields be terminated at the 7262 module. However, if your cable shield is attached to the sensor's housing, and the sensor is grounded through its mounting, you must not connect the cable shields to the 7262 module because this will create a ground loop.
- If a junction must be made in the signal cable, treat the shield as a signal-carrying conductor. Do not connect the shield to ground at any junction box or the encoder/sensor.
- If the signal cable must cross power feed lines, it should do so at right angles.
- Route the cable at least five feet from high voltage enclosures, or sources of "rf" radiation.

Latching Inputs Wiring

The following two diagrams show how you would wire the 7262 module's opto-coupler latching inputs to either sourcing or sinking sensors.

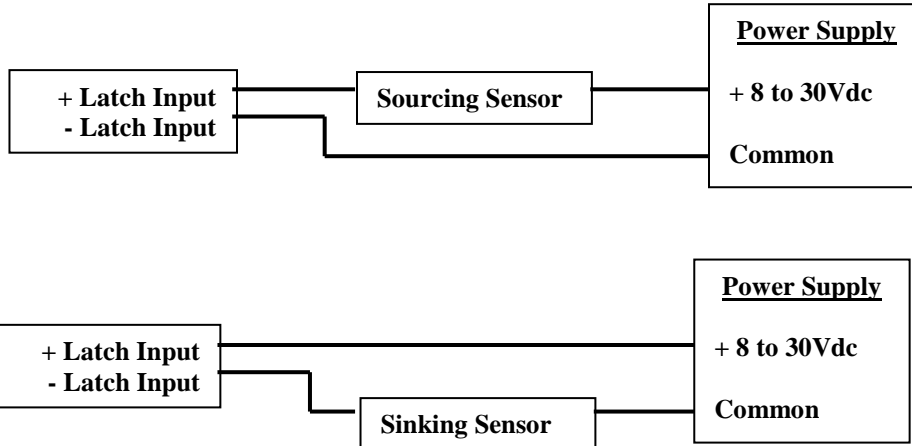

SSI Protocol

The following figure shows how a 7262 reads data from a SSI transducer. Note that the formal SSI definition allows for twenty-four bits of data and a twenty-fifth stop bit. However, AMCI is aware of some transducers that transmit more or less than twenty-five bits. To accommodate these transducers, the 7262 can be programmed to accept up to thirty-two bits in the SSI bit stream.

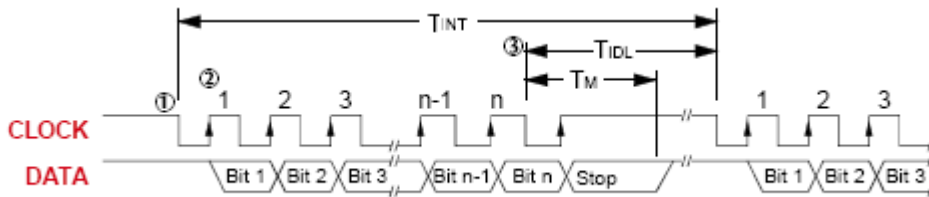

“n” = Number of bits in the SSI data. Range of 1 to 32. Default of 24.

1. The first falling edge of the clock signal latches the SSI data. Note: Some transducers latch the data at the end of the previous interrogation.
2. The next “n” rising edges of the clock shift out the “n” data bits.
3. TINT is the time between interrogations and is equal to $((1/\text{clock frequency}) * \# \text{ of SSI bits}) + \text{Idle Time}$ for the 7262. TM is the time that the Stop bit is valid, which is typically 12 to 20 μs . TIDL is the time between the end of one group of clock pulses and the start of the next group of clock pulses and varies with the number of channels that the 7262 module has been configured to use.

Number of Channels	Idle Time
1	130 μs
2	380 μs

4. The transducer must have new data available within the TIDL Time period if the system is to work properly.

Chapter 3: Programmable Parameters

The 7262 is configured by programming its Programmable Parameters. These parameters are broken down into three groups, Module Setup, SSI Setup, and Data Setup parameters.

The 7262 uses two methods for the programming and monitoring of data. Input and Output registers are used to program and monitor data that occurs on a regular schedule, such as reading the data value and status information or setting the system time. Message instructions are used for operations that occur less frequently, such as programming the module set up parameters or reading back the set up data for trouble shooting purposes.

Module Setup Parameters

Latched Input: The 7262 module has two Latch Inputs, one for each channel, that allow you to capture and display the current Data Value whenever the input transitions. This parameter, which is composed of two bits, allows you to capture the input on the 0 to 1 transition, the 1 to 0 transition, or on both transitions. The function of the Latched Input will be disabled if neither bit is set.

To be read by the 7262 module, the latching inputs must be on for between 0.2ms and 1.2ms, depending on the number of channels being used.

The 7262 module reports the status of the Latched input even if the function of the latched input has been disabled.

The Latched Value is not saved through power down. Therefore, the Latched Value displayed in the 7262 module's input registers at power up will be zero.

Interpolated Data value: This additional and optional feature may be useful for customers using the ControlLogix PLC's virtual axis functionality. If used, the 7262 module will take the PLC's *Central System Clock-Time* and the sensor's velocity data to calculate an Interpolated or "Look Ahead" Data value. This has two possible functions. One, the Interpolated Data Value along with the time value can be sent to other ControlLogix modules, for example the AMCI 8213-VA, allowing them to schedule their responses with a high degree of precision. Two, the Interpolated Data Value allows the user to "Look Ahead" to what the Data Value will be at a defined time in the future. Here is the procedure for generating the Interpolation Data Value.

1. Make the PLC the System Time Master by opening the Controller Properties and clicking on the Date/Time tab. Click on the box next to the "Make this controller the Coordinated System Time Master" text so that a check mark appears in the box and accept the changes by clicking on OK. The Interpolated position value will be valid only if this step is performed.
2. Create a GSV instruction in your ladder logic, with the Class Name set to CST and the Attribute Name set to CurrentValue, to read the system time from the PLC. The destination address must be made up of two DINT registers.
3. If desired, add a value to word 0 of the time value read above. This value is entered in 1 μ s increments, every 1000 equals 1ms, and equals the amount of time that you want to "look ahead."
4. Place the time value from step 3 into the output registers. The next time that the Interpolation Transmit bit transitions from either 0 to 1 or 1 to 0, the Central System Time will be sent to the 7262 module.
5. The latest Interpolation Data Value will be located in the input data the next time the module is updated at the normal RPI update.

Limit Switch Position: This two word parameters defines ON and OFF setpoints. If the ON setpoint is less than the OFF setpoint, a bit in the Input Registers, which can be easily interrogated by a relay instruction, will be set when the Data Value is between these two setpoints. If the ON setpoint is greater than then OFF setpoint, then the bit will be set when the Data Value is outside of the these two setpoints. A separate Limit Switch bit based on the same ON/OFF setpoints also exists for the Interpolation Data Value.

SSI Setup Parameters:

These parameters are used to extract the SSI Data Value from the bit stream. These parameters define the clock speed of the data transfer, the number of clock bits, the position and length of the SSI data within the bit stream, and the format of the data.

SSI Clock Frequency: This parameter allows you to set the SSI clock frequency to one of five values; 125kHz, 250kHz, 500kHz, 1.0MHz, or 2.0MHz. The default value of 125kHz value will work in all applications. Your sensor’s user manual should contain information on what SSI Clock Frequency is appropriate for both the sensor and the type and length of cable used.

Number of SSI Data Bits: This parameter defines how many bits of the data stream make up the Data Value. This parameter has a range of 1 to 32.

Most Significant Bit (MSB) Number: This parameter defines the bit location of the first bit of the Data Value in the data bit stream. This parameter has a range of 1 to 32.

Number of SSI Clock Bits: This value sets the number of bits that the 7262 will read from the SSI transducer per interrogation. This parameter has a range of 1 to 32 and must be greater than or equal to (*Most Significant Bit Number + (Number of SSI Data Bits – 1)*). The default value of 24 bits will work in most applications.

Example: You have a 12 bit single turn SSI encoder that outputs 25 SSI Clock bits. The single turn value is located in the least significant bits of the SSI data.

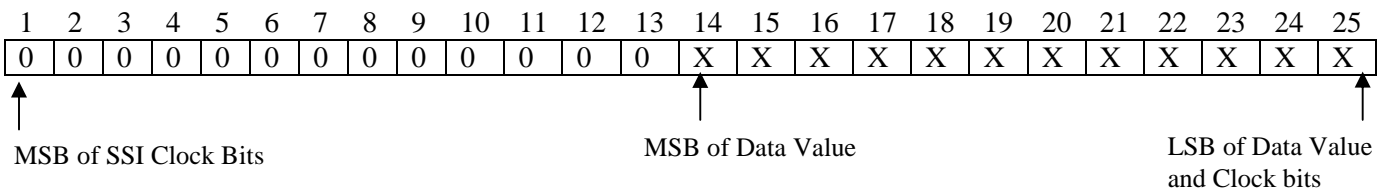

In this example, the 7262 module would be setup using the following data.

Number of SSI Clock Bits = 25
Most Significant Bit number = 14
Number of SSI Data Bits = 12

Data Type: This parameter tells the 7262 module to interpret the SSI data either as a binary number or as a gray code number. The default value is binary.

Data Logic: This parameter is included to handle situations where the SSI data is reported with negative logic. If this parameter is set, the 7262 will invert the data bits before performing any scaling and decoding operations. When left in its default value of positive, the 7262 module will use the SSI data as it is from the sensor.

Data Setup Parameters:

Once the 7262 module has extracted the SSI data from the data stream, it uses the Data Setup Parameters to convert the raw SSI data into the Data Value it reports to the PLC.

Scalar Multiplier & Divisor: These two parameters are used to scale the SSI data. Both parameters have a default value of one and can range in value from 1 to 32,767. The Scalar Multiplier must be less than or equal to the Scalar Divisor. In other words, the ratio of Multiplier to Divisor CANNOT be greater than one.

Linear displacement transducers from Balluff and MTS have resolutions measured in $\mu\text{m}/\text{count}$. The 7262 module can easily convert this data into the more familiar US Customary system of inches. The table below shows the Multiplier and Divisor values needed to convert from various metric resolutions to US Customary resolutions. For example, to convert data from a LDT sensor with $5\mu\text{m}/\text{count}$ resolution to $0.0005\text{inch}/\text{count}$ resolution, use a Multiplier of 50 and a Divisor of 127.

LDT Resolution	Desired Resolution						
	0.00005"	0.0001"	0.0002"	0.0005"	0.001"	0.002"	0.005"
1 μm	$\frac{100}{127}$	$\frac{50}{127}$	$\frac{25}{127}$	$\frac{10}{127}$	$\frac{5}{127}$	$\frac{5}{254}$	$\frac{1}{127}$
2 μm		$\frac{100}{127}$	$\frac{50}{127}$	$\frac{20}{127}$	$\frac{10}{127}$	$\frac{5}{127}$	$\frac{2}{127}$
5 μm			$\frac{125}{127}$	$\frac{50}{127}$	$\frac{25}{127}$	$\frac{25}{254}$	$\frac{5}{127}$
10 μm				$\frac{100}{127}$	$\frac{50}{127}$	$\frac{25}{127}$	$\frac{10}{127}$
20 μm					$\frac{100}{127}$	$\frac{50}{127}$	$\frac{20}{127}$
40 μm						$\frac{100}{127}$	$\frac{40}{127}$

Use the following procedure to calculate your Scalar and Divisor values if either your LDT Resolution or Desired Resolution does not appear in the above table

Conversion Factor: $\frac{\text{Desired Resolution (counts/inch)}}{\text{LDT Resolution (counts/inch)}}$

Step 1: Convert your LDT resolution from μm to inches. For example, you are using a sensor with $1\mu\text{m}$ resolution in your application.

$$1 \mu\text{m} * \frac{1 \text{ mm}}{1000 \mu\text{m}} * \frac{1 \text{ inch}}{25.4 \text{ mm}} = 0.00003937 \text{ inches/count} = 25400 \text{ counts/inch}$$

Step 2: Determine the number of counts per inch for the desired resolution. For example, $0.0001''$.

$$0.0001 \text{ inch/count} = 10000 \text{ counts/inch}$$

Step 3: Determine the Scalar Multiplier and Divisor values.

$$\frac{\text{Desired Resolution (counts/inch)}}{\text{LDT Resolution (counts/inch)}} = \frac{10000 \text{ counts/inch}}{25400 \text{ counts/inch}} = \frac{100}{254} = \frac{50}{127}$$

Therefore, to use a sensor with 1µm resolution and get 0.0001 inches per count resolution, use a Scalar Multiplier of 50 and a Scalar Divisor of 127.

Preset Value: The zero position of the SSI encoder's Data Value may not match the zero position of your machine. The Preset Value parameter gives you the ability to offset the Data Value from the actual SSI data to a value that will be more useful for your application.

Programming the Preset Value parameter does not change the Data Value. It is stored in the 7262 module's memory until the module sees a zero to one transition of the Apply Preset bit.

Apply Preset: Offsetting the Data Value to the Preset Value is a two step operation. First, a Message Instruction must be used to send the Preset Value with the other setup parameters to the 7262 module. Second, setting the Apply Preset in the output registers will change the Data Value to the Preset Value.

Setting the Apply Preset bit causes the module to generate an internal offset value that is applied to the Data Value before it is reported to the PLC. This internal offset is saved in the 7262 module's Flash memory, so it is not necessary to home the module at every power up. Please note that using a Message Instruction to program a channel's setup data will clear the internal offset generated by an Apply Preset operation.



The 7262 module's Flash memory is guaranteed for 10,000 write cycles before writing to it will cause it to fault. Therefore continuously applying the Preset should be avoided. If your application requires you to continuously apply the Preset, consider calculating and applying the Preset in your PLC program.

Count Direction: This parameter is useful if your Data Value represents a linear position. It gives you the ability to reverse the direction of motion needed to increase the position count. For simplicity's sake, the two values for this parameter are called *Positive Direction* and *Negative Direction*. When this parameter is set to its default of *Positive*, the Data Value is not changed. When this parameter is set to *Negative*, the Data Value is multiplied by -1 before it is reported. For linear transducers, this has the effect of reversing the direction of motion needed to increase the count. When using LDT's and the Count Direction is set to *Positive*, the Data Value usually increases as the magnet moves away from the head of the LDT. When the Count Direction is set to *Negative*, the Data Value increases as the magnet moves towards the head of the LDT. You will need probably need to Apply the Preset to the Data Value after you program the Count Direction parameter.

If your Data Value represents a rotary position, you cannot change the count direction with this parameter. However, you can easily reverse the count direction with ladder logic. This is accomplished with two rungs of logic. If the data value is equal to zero, do nothing, and if the data value is not equal to zero, subtract the current data value from the maximum value that your rotary encoder will output.

Velocity Update Time: The Velocity Update Time parameter sets the amount of time between Rate of Change information updates to the PLC. Its can be set to either 60 milliseconds or 160 milliseconds, with 160 milliseconds being the default. Decrease the time between updates for faster response to changes in this value. Increase the time between updates for better averaging of this value. The Velocity update time does not affect the rate at which the position data is updated.

The Velocity data is measured in Counts/Second.

Chapter 4: Message Instructions

The programming of the 7262 module's Setup data requires the use of Message Instructions. The format of this instruction is shown below.

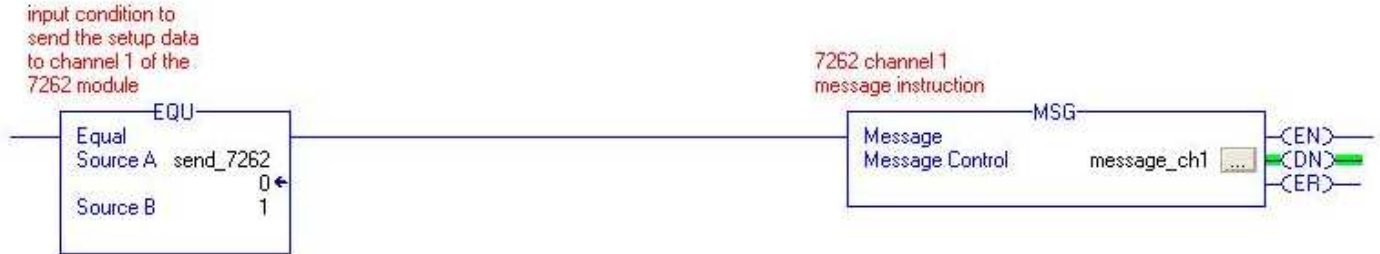

1. A different message instruction is needed for each channel of the 7262 module.
2. The message instruction sends data to or reads data from the 7262 module only when the rung transitions from false to true.
3. The Message Control tag, message_ch1 in this example, used for Message Instruction Control must have the MESSAGE data type.
4. Clicking on the button in the Message Instruction opens the Message Configuration Window, shown below. Enter the appropriate data for the channel and operation being performed. When finished, click on the Apply button to accept the new data.

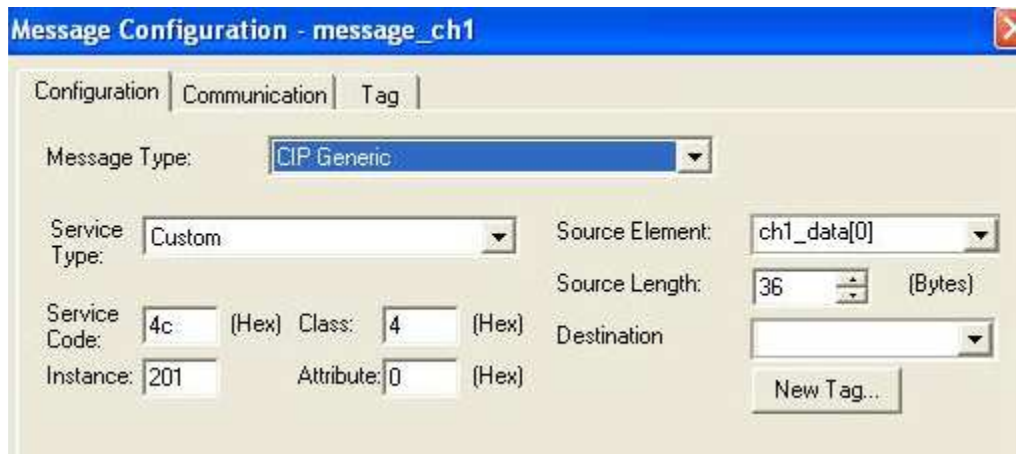

Message Type: CIP Generic

Service Type: Must be Custom

Service Code: 4C to write data to the 7262 module, 4B to read data from the 7262 module

Class: Must be equal to 4.

Instance: Determined by the type of data being transferred, see the table below.

Attribute: Must be set to zero.

Source Element: If the Message Instruction is being used to send data to the 7262 module, then the source parameter will be the first tag of the array that contains the data to be sent to the 7262 module.

If the Message Instruction is being used to read data from the 7262 module, then the source parameter must be left blank.

Source Length: If the Message Instruction is being used to send data to the 7262 module, then the Source Length parameter must be equal to 36 bytes.

If the Message Instruction is being used to read data from the 7262 module, then the Source Length Parameter must be set to zero.

Destination: If the Message Instruction is being used to send data to the 7262 module, then the Destination Parameter must be left blank.

If the Message Instruction is being used to read data from the 7262 module, then the Destination Parameter must be set to the first tag of the array where the data will be placed.

The Message Instruction is used with the following information to send Setup Data to the 7262 module.

SSI Channel 1	SERVICE CODE	4C	CLASS	4	Length in [Bytes] 36	Used with assembly instances 101, 102
	INSTANCE	201	ATTRIBUTE	0		
SSI Channel 2	SERVICE CODE	4C	CLASS	4	Length in [Bytes] 36	Used with assembly instance 102
	INSTANCE	202	ATTRIBUTE	0		

The Message Instruction is used with the following information to read Setup Data from the 7262 module.

SSI Channel 1	SERVICE CODE	4B	CLASS	4	Length in [Bytes] 0	Used with assembly instances 101, 102
	INSTANCE	201	ATTRIBUTE	0		
SSI Channel 2	SERVICE CODE	4B	CLASS	4	Length in [Bytes] 0	Used with assembly instance 102
	INSTANCE	202	ATTRIBUTE	0		

Message Configuration – (Communication Tab)

When the Configuration window shown above is completed, click on the Communication tab. The following window will open. Click on the Browse button and set the path parameter to the slot where the 7262 module is located. All of the remaining Communication parameters can remain at their default settings.

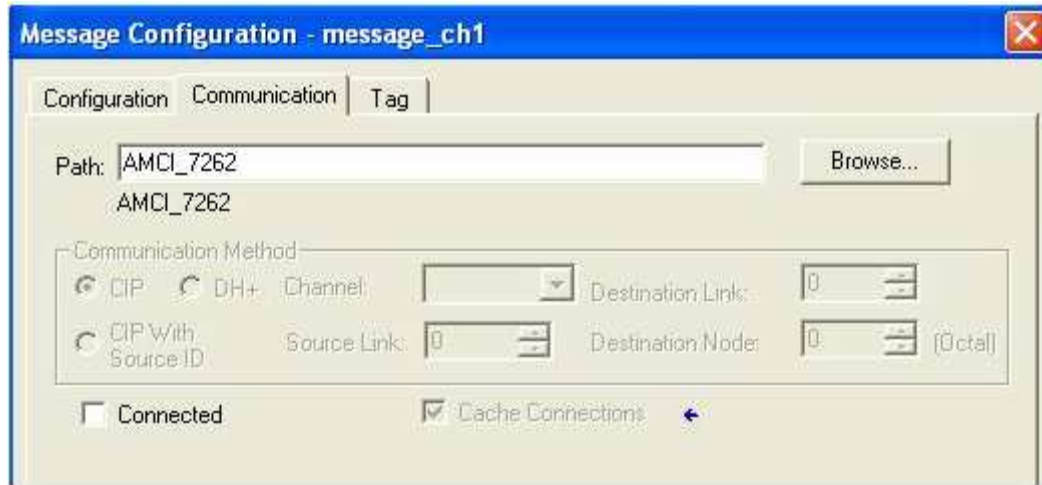

Extended Error Codes

The Message Instructions used to send data to the 7262 module have an error register that can be used to obtain diagnostic information from the module. This register's address is *user_tag.exerr*. The following table shows the values that will be displayed in this register if the data sent to the 7262 module is not valid.

Extended Error Codes
1 = Configuration Bits Word Format Error <ul style="list-style-type: none"> • Reserved bits not equal to 0 • Using one of the three reserved clock frequency patterns
2 = Starting MS Bit Position outside the range of 1 to 32
3 = Number of Data Bits outside the range of 1 to 32
4 = Number of Clock Bits outside the range of 1 to 32
5 = (Starting MS Bit Position + Number of Data Bits - 1) > Number of Clock Bits
6 = Multiplier outside the range of 1 to 32767
7 = Divisor outside the value range 1 to 32767
8 = Multiplier > Divisor
10 = Channel not used (This will be displayed as 16#0000_000A)

- These error codes are only valid when register address *user_tag.err* is equal to 9.
- The Message Instructions Error bit and the Extended Error Code can only be cleared by sending valid data to the 7262 module.

Chapter 5: Setup Data

The message instructions described in chapter 3 above are used to send the setup data to the two channels of the 7262 module. This data consists of nine 32 bit words (36 bytes) shown in the following table. Each channel can be programmed with different setup data.

Setup Data for the SSI Module

Data Type	Word Number	Function	Range	Factory Default
32-bit	0	Configuration Bits	See Description Below	0
32-bit	1	Starting MS Bit position	1 to 32	1
32-bit	2	Number of Data Bits	1 to 32	24
32-bit	3	Number of Clock Bits	1 to 32 (<i>See Note 2</i>)	24
32-bit	4	Multiplier	1 to Divisor	1
32-bit	5	Divisor	1 to 32767	1
32-bit	6	Preset Value	0 to 16# FFFF_FFFF	0
32-bit	7	Limit Switch ON-Position	0 to 16# FFFF_FFFF	0
32-bit	8	Limit Switch OFF-Position	0 to 16# FFFF_FFFF	0

All of the data must be present and valid when the message instruction is used to send the data to the 7262 module. If the data is not valid, all of the data will be ignored, the message instruction's error bit will be set, and the extended error code will indicate exactly how the data is invalid. See chapter 3 for definitions of the set up parameters.

Configuration Bits:

- Bits 0 to 7:** Reserved, must be 0;
- Bit 8:** Program Count Direction (0 = Positive, 1 = Negative)
- Bit 9:** Program Velocity Update (0 = 160ms, 1 = 60ms)
- Bit 10:** Latch position on rising edge of input
- Bit 11:** Latch position on falling edge of input
- Bit 12:** SSI Data Logic (0=positive, 1=negative)
- Bit 13:** SSI Data Type (0=binary, 1=Gray Code)
- Bit 14 to 16:** SSI Frequency

Bit 16	Bit 15	Bit 14	SSI Clock Frequency
0	0	0	125kHz
0	0	1	250kHz
0	1	0	500kHz
0	1	1	1MHz
1	0	0	2MHz
1	0	1	reserved
1	1	0	reserved
1	1	1	reserved

- Bits 17.. 31:** Reserved, must be 0;

Note 1: The Velocity Update Time does not affect the update of the Data Value.

Note 2: The Number of Clock Bits cannot be less than the sum (Starting MS Bit Position + Number of Data Bits - 1)

Note 3: Programming a channel's setup data will clear the internal offset generated by an Apply Preset Operation.

Note 4: The 7262 module will accept and act on Setup Data sent from a Message Instruction that occurs in a Listen Only Processor.

Chapter 6: Reading Status Data

The message instructions described in chapter 4 above can be used to read the current setup data from each of channels of the 7262 module. This status data consists of ten 32 bit words, shown in the following table. The destination address must be made up of a tag array that is at least 10 DINT words long.

Please note that it is possible to read only valid data from the 7262 module. The module does not store any Setup Data that caused the Message Instruction's Error bit to be set.

Reading Data from the SSI Module

Data Type	Word Number	Function
32-bit	0	Configuration Bits (see description below)
32-bit	1	Starting MS Bit position
32-bit	2	Number of Data Bits
32-bit	3	Number of Clock Bits
32-bit	4	Multiplier
32-bit	5	Divisor
32-bit	6	Preset Value
32-bit	7	Limit Switch ON-Position
32-bit	8	Limit Switch OFF-Position
32-bit	9	Internal Offset generated by an Apply Preset operation

Configuration Bits:

- Bits 0 to 7:** Reserved, must be 0;
- Bit 8:** Program Count Direction (0 = Positive, 1 = Negative)
- Bit 9:** Program Velocity Update (0 = 160ms, 1 = 60ms)
- Bit 10:** Latch position on rising edge of input
- Bit 11:** Latch position on falling edge of input
- Bit 12:** SSI Data Logic (0=positive, 1=negative)
- Bit 13:** SSI Data Type (0=binary, 1=Gray Code)
- Bit 14 to 16:** SSI Frequency

Bit 16	Bit 15	Bit 14	SSI Clock Frequency
0	0	0	125kHz
0	0	1	250kHz
0	1	0	500kHz
0	1	1	1MHz
1	0	0	2MHz
1	0	1	Reserved
1	1	0	Reserved
1	1	1	Reserved

Bits 17.. 31: Reserved, will be 0;

Chapter 7: Input & Output Data

Input Registers: (Data sent from the 7262 module to the PLC)

The input data consists of six (for 1 channel) or twelve (for 2 channels) 32-bit words, and is read by the PLC at the RPI (Requested Packet Interval) Time that is asynchronous to the Ladder Logic Program. The Input data will be referenced as Local:X.I.Data[Y] where “X” is the slot number and “Y” is the word number.

To ensure that the same data is used throughout the entire PLC program, this data should be buffered to internal registers at one place in the program. However, in order to take advantage of the real time availability of the *Interpolation Data value*, the *Interpolation Acknowledge bit*, the *Limit Switch State Bit*, and the *Interpolation Limit Switch State Bit* should be used directly from their respective Input Registers.

The data contained in the input registers consists of Status Words, Data Values, Velocity, the Actual SSI data, and any associated Latched or Interpolated Data Values.

Input Data for the 1 Channel Configuration

Channel Number	32 Bit Word	Function	Units
1	0	Status Word1	See descripton below
	1	Data Value 1	
	2	Velocity 1	Counts / Second
	3	Latched Data Value 1	
	4	Interpolated Data Value 1	
	5	Actual SSI Value 1	

Input Data for the 2 Channel Configuration

Channel Number	32 Bit Word	Function	Units
1	0	Status Word 1	See descripton below
	1	Data Value 1	
	2	Velocity 1	Counts / Second
	3	Latched Data Value 1	
	4	Interpolated Data Value 1	
	5	Actual SSI Value 1	
2	6	Status Word 2	See descripton below
	7	Data Value 2	
	8	Velocity 2	Counts / Second
	9	Latched Data Value 2	
	10	Interpolated Data Value 2	
	11	Actual SSI Value 2	

Description of the Status Word:

- Bit 0:** APPLY PRESET ACKNOWLEDGE: This bit will be set when the corresponding Apply Preset Command bit is set in the output registers.
- Bit 1:** INTERPOLATION ACKNOWLEDGE: This bit will be set when the corresponding Interpolation Command bit is set in the output registers, after carrying out the INTERPOLATION operation.
- Bit 2:** VELOCITY AT ZERO: Set when there has been no motion for the last portion of the Velocity Update Time.
- Bit 3:** MOTION DIRECTION: Set when data value is decreasing. The bit remains in the last state when there is no motion.
- Bit 4:** LATCHING INPUT: Set when the latching input for respective channel is receiving power. This bit will be set to indicate that the input is active even if the function of the input has been disabled by the channel's programming.
- Bit 5:** LIMIT SWITCH STATE: Set when the data value is between the programmed Limit Switch *ON-* and *OFF-Setpoints*.
- Bit 6:** INTERPOLATION LIMIT SWITCH STATE: Set when the interpolated data value is between the programmed Limit Switch *ON-* and *OFF-Setpoints*. This bit will only be updated on the 0 to 1 or 1 to 0 transitions of the Interpolation Command Output bit.
- Bits 7 to 13:** Reserved for future use
- Bit 14:** OUTPUT FAULT: Set when one or more of the bits in the corresponding COMMAND WORD are set. This bit will be automatically reset when the incorrect bit(s) are reset.
- Bit 15:** BAD CRC Memory Error: Set when the flash area for the corresponding channel parameters shows corrupt data. It will still be possible to use the 7262, but the module will power up using its default parameters. That is, you will have to use message instructions to program your setup data at every power up. If you do not want to use the module in this way, it must be returned to AMCI for repair.
- Bits 16 to 31:** Reserved for future use

Input Register Description

Data Value: This register contains the converted and scaled data from the sensor.

Velocity: This is the rate of change of the data value in Counts / Second.

Latched Data Value: This register shows what the Data Value was when the Latch Input transitioned, depending on the configuration, from 0 to 1 and or from 1 to 0. The Latched Data Value will be reset to zero at power up. Also, the current Data Value will be placed in this register if the input is configured for the 0 to 1 transition and the input is active at power up.

Interpolated Data Value: This register shows the Data Value based on the Central System Time and the sensor's velocity data. It is not necessary to use this feature if you are only interested in reading the Data Value and Velocity directly from the sensor.

Actual SSI Data: The Actual SSI Data is the unmodified data as it is received directly from the sensor. That is, before any offset, scalars, or data conversion operations are performed. This data is reported to allow you to detect any error or status bits that your sensor may place in the data stream.

Additionally, the Actual SSI Data can be used to detect if your sensor or power supply are not functioning. If either are not working, this register will show a value that is equal to having all of the clock bits set. For example, if you have programmed the unit for 24 clock bits, the actual SSI Data will show a value equal to 16777215 (16#00FF FFFF).

Output Registers: (Data sent from the PLC to the 7262 module)

The output registers are used to execute commands that typically occur during machine operation, while module setup functions are accomplished with the use of Message Instructions. See chapter 3 and 4 for configuring the 7262 module.

1 Channel configuration

Channel Number	32 Bit Word	Function
1	0	Command Bits
	1	Interpolation CST Value

2 Channels configuration

Channel Number	32 Bit Word	Function
1	0	Command Bits
	1	Interpolation CST Value
2	2	Command Bits
	3	Interpolation CST Value

Command Bits for channels 1 & 2:

Bit 0: *APPLY PRESET COMMAND*: The 0 to 1 transition of this bit changes the respective channel's Data Value to the Preset Value that was programmed with the channels Setup Message Instruction. The Default Preset Value is zero.

Bit 1: *INTERPOLATION COMMAND*: Both transitions of this bit, (0 to 1) and (1 to 0), causes the respective channel to read the Current System Time from the output register and calculate the Interpolated Data Value. This Interpolated Data Value will be read by the PLC during the next RPI update of the module.

Bits 2 to 31: Reserved for future use

Apply Preset Programming Cycle

1. The ladder logic program sets the APPLY PRESET COMMAND bit when you want to change the channel's current Data Value to the previously programmed Preset Value.
2. The 7262 module will set the APPLY PRESET ACKNOWLEDGE bit in the input registers to indicate that it has received the command.
3. When the ladder logic program sees that the APPLY PRESET ACKNOWLEDGE bit is set, it will reset the APPLY PRESET COMMAND bit. The programming cycle is now complete.



WARNING

The 7262 module's Flash memory is guaranteed for 10,000 write cycles before writing to it will cause it to fault. Therefore continuously applying the Preset should be avoided. If your application requires you to continuously apply the Preset, consider calculating and applying the Preset in your PLC program.



WARNING

Programming the 7262's setup parameters will reset the internal offset generated by an Apply Preset operation. If you are programming the unit's setup parameter at every power up, this may be the reason that your data value to not be absolute through power down.

Interpolation Command Programming Cycle

1. The ladder logic program reads the desired *Central System Time* value from the PLC using a GSV instruction. The Destination tag must consist of at least two DINT registers.
2. If desired, add the amount of time, in microseconds, that you want to “look ahead” to the lower word of Central System Time.
3. Write the desired *Central System Time* value into the *Interpolation CST Value Output Register*.
4. Based on the state of the Interpolation Acknowledge bit, toggle the Interpolation Command bit either on or off.
5. Based on the measured *Velocity* for the corresponding sensor channel, the 7262 module calculates the *Interpolated Data Value* and places it in the respective *Input Register*. The 7262 module then adjusts the *Interpolation Acknowledge Bit* accordingly.

If desired, the user can send the Interpolated Position, along with the system time, to another ControlLogix module each time the Interpolation Acknowledged bit changes state.

The following is an example of the ladder logic that can be used to generate the Interpolation Data Value.

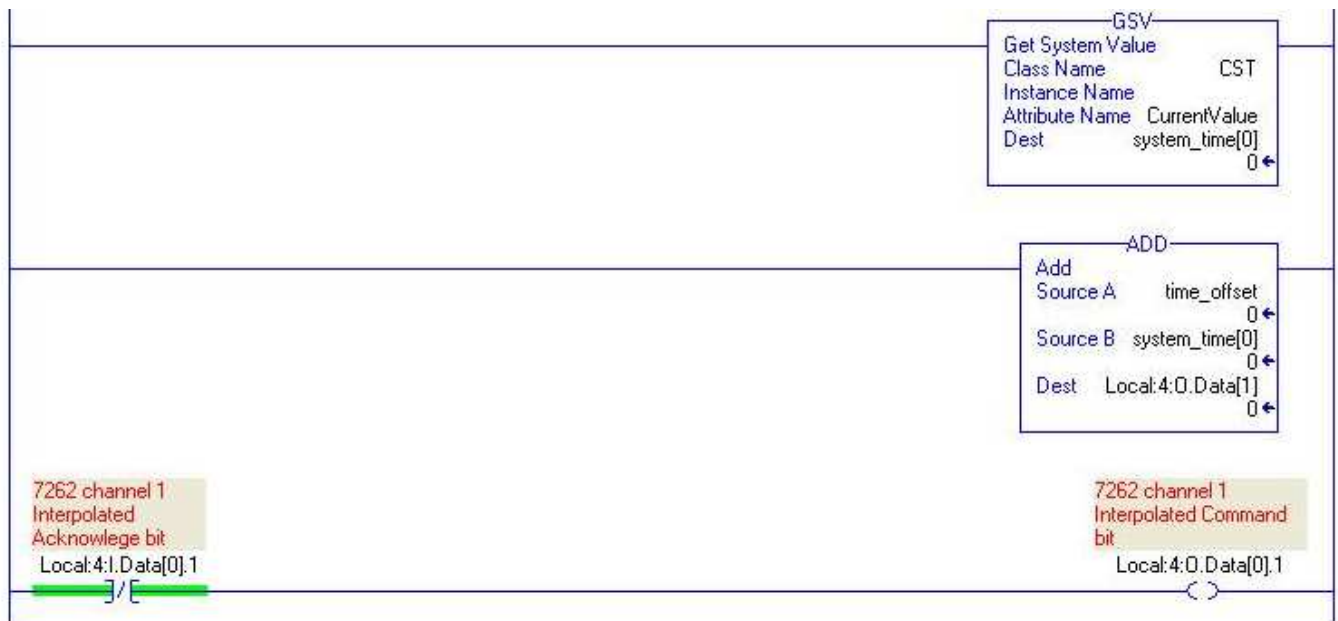

Chapter 8: Manual Revision History

Revision 0.0 was created 05/23/08 and was the initial release of the specifications.

Revision 1.0 was created on 6/16/08. The I/O configuration size was corrected. It should have been 6 (for one channel) or 12 (for two channels).

Revision 1.1 was created on 6/1/09. Corrected a problem in the Interpolated Programming cycle sample program.

Revision 1.2 was created on 8/28/09. The latch inputs are differential, not sinking. Added wiring diagrams for the latch inputs. The number of setup words was incorrectly listed to be 10 bytes when it is 36. Also, the number of input words was listed as being one word short per channel.