

SSI DURACODER

RS422/485 COMMUNICATIONS

This document details how to read position values and parameter data from an SSI DuraCoder over the RS422/485 link. This information is primarily for users of industrial computers that do not have an SSI interface card.

With the exception of setting the baud rate, information on writing parameter values is not included in this document. AMCI has a Windows compatible program on our website (www.amci.com) for this purpose. This program is called SSI_Duracoder.exe and is available off of our SSI DuraCoder page.

The baud rate is not stored in non-volatile memory and defaults to 9600 on every power up. This guarantees that you will be able to communicate with the unit. (Just think about what would happen if there was an error storing the baud rate parameter. At best, the baud rate is now a random value. At worst, the baud rate is invalid and all serial communication to the DuraCoder is lost until the unit is repaired.)

RS422/485 Comm Port

This document assumes that your RS422/485 communications port is already installed on your computer and is functioning, which means that any and all drivers needed to support the device are also installed.

If you are using the USB-to-serial adapter sold by AMCI, a driver disk is included with the adapter. If you cannot find the disk, the drivers can be downloaded from the manufacturer's website at:

- http://www.vsc.com.de/produkte/vscom_usb-com-i.html.

DuraCoder Pinout

The figure to the right shows the pins you need to connect to on the SSI DuraCoder. It also shows the connections to the USB-to-serial adapter sold by AMCI.



The pinout is verified for the USB-to-serial adapter available from AMCI. If you are not using this adapter, verify the wiring to your communications port before applying power. If the wiring is incorrect, the SSI DuraCoder or your adapter may be damaged.

Note that the \pm RxD pair of the SSI DuraCoder is connected to the \pm TxD pair on your communications port and the \pm TxD pair is connected to the \pm RxD pair.

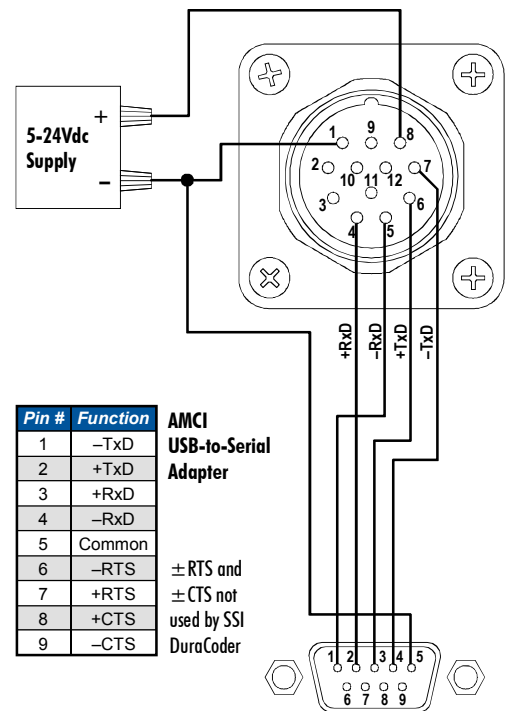

Figure 0.1 SSI DuraCoder serial port wiring

RS422/485 Default Parameters

Your RS422/485 port will have to be set to the same parameter values used by the SSI DuraCoder. SSI DuraCoders have the following default values. Only the baud rate can be changed on the DuraCoder, and this must be done on every power up if you want it to communicate at a rate other than 9600 baud. Information on changing the baud rate is given in the last section of this document.

Parameter	Value
Baud Rate	9600
Data Bits	8
Stop Bits	1
Parity	None
Flow Control	None

On Windows 2000 and XP systems, port settings can be changed from the Device Manager applet. Click on the [Start] button and select [Run]. In the drop down box type in “devmgmt.msc” and click on [OK]. Find the communications port you’ll be using with the DuraCoder, which usually will be under “Ports (COM & LPT)”. Right click on the communication port and select “Properties” from the menu. In the windows that opens, click on the ‘Port Settings’ tab and change your parameter values.

It may also be possible to set these values in your software when you open the port.

Communications Protocol

The SSI DuraCoder uses a simple polling protocol to exchange information over the RS422/485 link. When reading parameter values or the position data, your program must write a four byte command to the DuraCoder. The DuraCoder immediately responds with the requested information. The DuraCoder then waits for the next request before sending any additional information.

Read Command

The figure below shows the format of the four byte read command. The value of the *Parameter ID* specifies the data you want back from the DuraCoder. Values for the Parameter ID are also shown.

Byte	Value
1	0x67
2	Parameter ID
3	0x0D
4	0x0A

0x67 = ASCII 'g'
 0x0D = ASCII Carriage Return Code
 0x0A = ASCII Line Feed Code

ID	Read Parameter
1	SSI Output Mode
2	Number of Turns (Multiturn Units Only)
3	Full Scale Count
4	Baud Rate
5	Encoder Type
6-8	Not Used
9	Position Value

Figure 0.2 Read Command Format

RS422/485 COMMUNICATIONS

Communications Protocol (continued)

Read Response

Once these four bytes are written to the SSI DuraCoder, it responds with the requested data. Its response is between six and nine bytes long, depending on the length of the data you requested. The figure below shows the general format of the response. If there is an error, the Error Code byte will be non-zero and the Parameter Value is not included. Because of this, all error responses are five bytes long.

Command Code	Parameter ID	Parameter Value	Error Code	Delimiter
0x47	Echo of Parameter ID	Requested Data	Results of Last Command	0x0D / 0x0A
(1 Byte)	(1 Byte)	(1, 2, or 4 Bytes)	(1 Byte)	(2 Bytes)

Figure 0.3 Read Response Format

- 1) The Command Code is always 0x47, which is a 'G' in ASCII.
- 2) The Parameter ID is an echo of the last Parameter ID written to the SSI DuraCoder by the Read Command. This value can be used to determine what data is being sent by the DuraCoder. The meaning of the Parameter ID can be found in figure 0.2 on the preceding page
- 3) An explanation of the available Parameter Values is given in the table below.
- 4) The Error Code byte gives feedback on the present state of communications.
 - 0x00 = No Errors
 - 0x01 = Baud Rate Error (Used with programming only. You will not see this error when reading information from the DuraCoder.)
 - 0x02 = Flash Memory Error (Used with programming only. You will not see this error when reading information from the DuraCoder.)
 - 0x03 = Wrong Command (Command Byte not equal to 0x67)
 - 0x04 = Wrong Parameter ID (Parameter ID not equal to 1, 2, 3, 4, 5, or 9 OR Parameter ID set to 2 when using a single turn SSI DuraCoder.)
 - 0x05 = Wrong Parameter Value (Used with programming only. You will not see this error when reading information from the DuraCoder.)
 - 0x06 = Fatal Error. Cycle power to the SSI DuraCoder. If error still exists, contact AMCI Technical Support for assistance.
- 5) The two byte delimiter are the ASCII codes for 'Carriage Return' and 'Line Feed'

Communications Protocol (continued)

Parameter Lengths, Ranges and Defaults

Parameter	Length	Range	Default
SSI Output Mode ^a	1 Byte	1 = Gray Code 2 = Natural Binary	Natural Binary
Number of Turns	2 Bytes	1 to 4096	1 if single turn unit 4096 if multiturn unit
Number of Counts	4 Bytes	2 to (4096*Number of Turns)	4096 if single turn unit 2 ²⁴ if multiturn unit (4096*4096) (16,777,216)
Baud Rate	1 Byte	0x04=1200 0x05=2400 0x06=4800 0x07=9600 0x08=19200 0x09=38400 0x0A=57600 0x0B=115200	9600
Encoder Type	1 Byte	1 = Single Turn, 2 = Multi-Turn	Set by part number

- a. SSI Output Mode refers to the format of the SSI position data. The position data is always transmitted over the serial link in natural binary, right justified to the least significant byte. For example, a position value of 5,460,809 equals 0x535349 and the four bytes that contain the position data would be transmitted as 0x00 0x53 0x53 0x49. Note that these are ordinal numbers, not ASCII characters. In ASCII, the string would be a blank space followed by “SSI”.

Setting the Baud Rate

Write Baud Rate Command

The baud rate is set to 9600 baud on every power up to prevent a situation where you cannot communicate with the DuraCoder because you do not know the baud rate. Changing the baud rate on an SSI DuraCoder requires a five byte *Write Baud Rate* command. If the unit accepts the command without error, it will write a response to the command at the present baud rate before switching to the new one. If there is an error, the DuraCoder will remain at the present baud rate after its response.

The format of the Write Baud Rate command is shown below.

Byte	Value
1	0x73
2	0x04
3	Baud Rate ID
4	0x0D
5	0x0A

ID	Baud Rate
0x04	1200
0x05	2400
0x06	4800
0x07	9600
0x08	19200
0x09	38400
0x0A	57600
0x0B	115200

0x73 = ASCII 's'
 0x0D = ASCII Carriage Return Code
 0x0A = ASCII Line Feed Code

Figure 0.4 Write Baud Rate Command

RS422/485 COMMUNICATIONS

Setting the Baud Rate (continued)

Write Baud Rate Response

Once the command is accepted, the SSI DuraCoder responds with a five byte reply.

Byte	Value	ErrorCode	Description
1	0x53	0x00	No Errors
2	0x04	0x03	Byte 1 of the Write Baud Rate command not equal to 0x73.
3	ErrorCode	0x04	Byte 2 of the Write Baud Rate command not equal to 0x04.
4	0x0D	0x05	Baud Rate ID outside the range of 0x04 to 0x0B
5	0x0A	0x06	Fatal Error. Cycle power. If problem remains, call AMCI.

0x73 = ASCII 'S'
0x0D = ASCII Carriage Return Code
0x0A = ASCII Line Feed Code

Figure 0.5 Write Baud Rate Response

After this reply is received, check the ErrorCode value. If it equals 0x00, the SSI DuraCoder has accepted the command and has switched to the new baud rate.