

R11X-C10/7 Specification Sheet

SHEET # 940-2T301

DESCRIPTION

Designed for reliable operation the R11X-C10/7 can be used in a wide range of applications. The brushless resolver is unsurpassed by any other type of rotary position transducer. Use this resolver for space critical applications where environmental sealing is not needed. The resolver provides absolute position of the input shaft and being ratiometric, any changes in the resolvers characteristics, such as those caused by aging, frequency, voltage or a change in temperature are ignored. Due to the small shaft size a flexible coupler must be used when connecting the resolver to your machinery. Note that this resolver is not directly compatible with most AMCI electronics. It is designed to be used with Namco/C&A and ElectroCam products.

DIMENSIONAL DRAWING

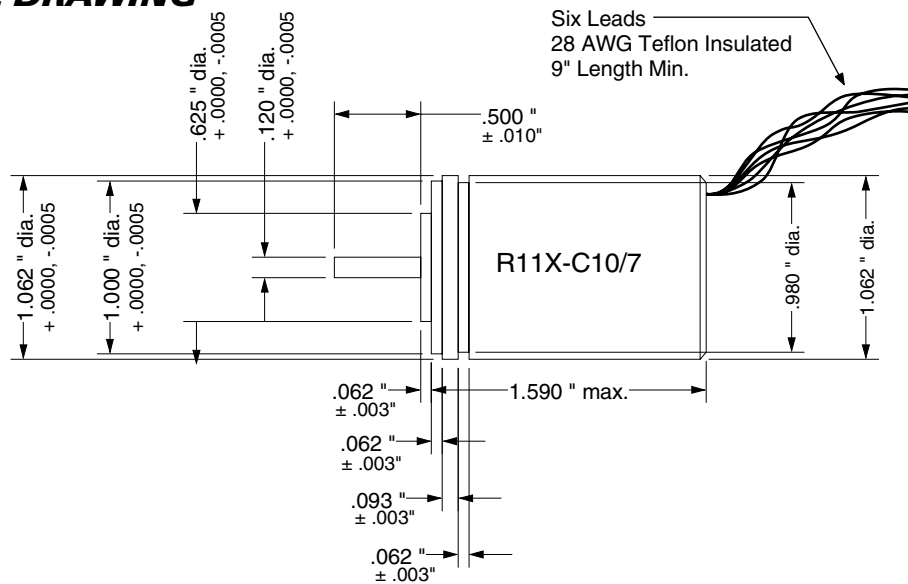

SCHEMATIC

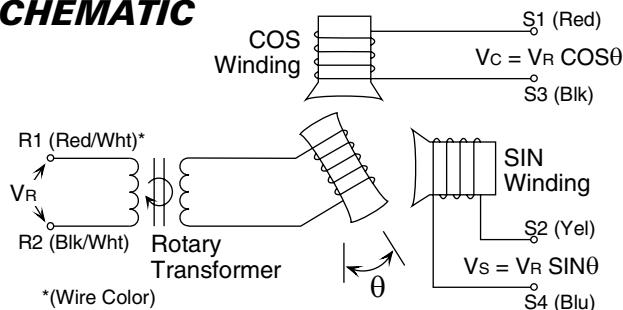

Sample Installation

The picture below shows how to connect a R11X-C10/7 to AMCI's standard cable.

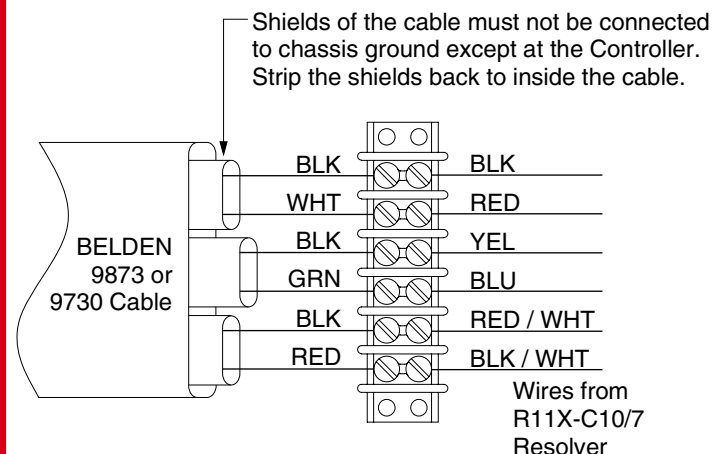

SPECIFICATIONS

- Input Voltage: 6.0 V
- Input Freq: 1000 Hz
- Primary: Rotor
- Input Current: 17.0 mA Max.
- Output Voltage: 2.7 V Nom.
- Trans. Ratio: 0.45 ± 5%
- Accuracy: 7 min. (max. error)
- NEMA Rating: NEMA 1