

SD7540A Stepper Drive

User Manual



AMCI Motion Control Products

Important User Information

The products and application data described in this manual are useful in a wide variety of different applications. Therefore, the user and others responsible for applying these products described herein are responsible for determining the acceptability for each application. While efforts have been made to provide accurate information within this manual, AMCI assumes no responsibility for the application or the completeness of the information contained herein. Throughout this manual the following two notices are used to highlight important points.

WARNINGS tell you when people may be hurt or equipment may be damaged if the procedure is not followed properly.

CAUTIONS tell you when equipment may be damaged if the procedure is not followed properly. No patent liability is assumed by AMCI, with respect to use of information, circuits, equipment, or software described in this manual. The information contained within this manual is subject to change without notice. UNDER NO CIRCUMSTANCES WILL ADVANCED MICRO CONTROLS, INC. BE RESPONSIBLE OR LIABLE FOR ANY DAMAGES OR LOSSES, INCLUDING INDIRECT OR CONSEQUENTIAL DAMAGES OR LOSSES, ARISING FROM THE USE OF ANY INFORMATION CONTAINED WITHIN THIS MANUAL, OR THE USE OF ANY PRODUCTS OR SERVICES REFERENCED HEREIN.

Standard Warranty

ADVANCED MICRO CONTROLS, INC. warrants that all equipment manufactured by it will be free from defects, under normal use, in materials and workmanship for a period of [18] months. Within this warranty period, AMCI shall, at its option, repair or replace, free of charge, any equipment covered by this warranty which is returned, shipping charges prepaid, within one year from date of invoice, and which upon examination proves to be defective in material or workmanship and not caused by accident, misuse, neglect, alteration, improper installation or improper testing. The provisions of the "STANDARD WARRANTY" are the sole obligations of AMCI and excludes all other warranties expressed or implied. In no event shall AMCI be liable for incidental or consequential damages or for delay in performance of this warranty.

Returns Policy

All equipment being returned to AMCI for repair or replacement, regardless of warranty status, must have a Return Merchandise Authorization number issued by AMCI. Call (860) 585-1254 with the model and serial numbers along with a description of the problem. A "RMA" number will be issued. Equipment must be shipped to AMCI with transportation charges prepaid. Title and risk of loss or damage remains with the customer until shipment is received by AMCI.

24 Hour Technical Support Number

Technical Support, in the form of documents, FAQs, and sample programs, is available from our website, www.amci.com. 24 Hour technical support is also available on this product. For technical support, call (860) 585-1254. Your call will be answered at the factory during regular business hours, Monday through Friday, 8AM - 5PM EST. During non-business hours, an automated system will ask you to leave a detailed message and the telephone number that you can be reached at. The system will page an engineer on call. Please have your product model number and a description of the problem ready before you call.

Revision History

This manual, AMCI number 940-0S041, supersedes 940-0S040. First released May 5, 2026, it updates several drawings and slightly modifies the format. It applies to SD7540A stepper drives with a serial number D0810001 and above.

The AMCI SD7540A Stepper Drive

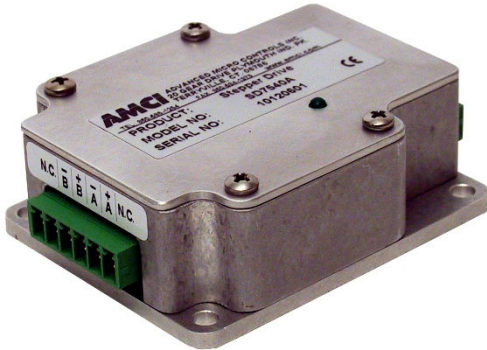

The SD7540A is a powerful stepper motor drive in a low cost, compact package. Externally powered from a 24 – 75 VDC power supply, this drive pack can operate up to NEMA size 34 motors.

With up to 4 Amps rms(5.66 Amps peak) of half step and microstepping capabilities, this drive pack provides higher speed and torque than any other drive in its class. Yet, it is easy to connect to any differential or transistor pulse and direction motion controller signal.

Features

- ✗ Compact Design – 2.2”X2.6” footprint
- ✗ Optimized drive design
- ✗ Industry standard Step/Direction control signals
- ✗ More torque at higher speeds than competitive designs
- ✗ Wide range of operating voltages, 24-75Vdc
- ✗ Speeds to 2000 RPM
- ✗ Anti-resonance circuitry
- ✗ Motion controlled by Step & Direction input signals
- ✗ Easy to use configuration software
- ✗ Uses standard RS232 interface for programming
- ✗ Programmable motor current
- ✗ Programmable Idle Current Reduction
- ✗ 400, 1000, 2000, or 5000 selectable step resolution
- ✗ AMCI quality and reliability
- ✗ Single power supply

The SD7540A uses step and direction control signals generated from an external source such as AMCI’s 3202 or 3601 stepper control modules. A logical diagram of the inputs is shown below.

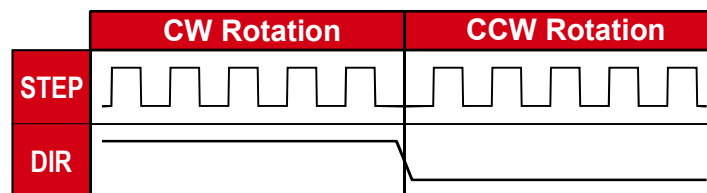

The SD7540A is powered by an external DC supply with an operating range of 24 to 75Vdc. There is an additional control input that can be used to disable the motor. This input can be left floating if you are not using the disable motor feature.

SD7540A Specifications

Environmental Specifications

Supply Voltage

24Vdc to 75Vdc max, 4 Arms maximum, user supplied.



The maximum supply input voltage includes power supply ripple and motor back EMF.

Operating Temperature

32° to 122°F (0° to 50°C) Also, see Operating Notes on the following page.

Storage Temperature

-40° to 185°F (-40° to 85°C)

Relative Humidity

0 to 95%, non-condensing

Electrical Specifications

Motor Current

User Selectable – 4.0 Arms max 0.4 –4.0 Arms in 0.4 increments (10%-100%)
Default value – 3.20 Arms (80%)

Steps per Revolution

400, 1000, 2000, and 5000 – user selectable
Default value – 2000 steps/rev
Frequency on the Step input (max) - 100KHz

Idle current reduction time

1 sec

Idle current selection

0% to 70% of the maximum operating current
Default Value: 20%

Digital Inputs

Three opto-isolated differential inputs:

Step – Velocity/position command

Direction – Direction Control

Disable – Disables motion by reducing motor current to zero. The pins for this input can be left open if the input is not used in your application.

Type of input

5V TTL logic

Input Current

15mA max

Input Connector

AMCI Part # MS-8P, provided (Phoenix part # MC 1.5/8-ST3.81)
8 screw terminal type – 16 AWG max.

Configuration Programming

Interface – RS232

Programming Software – AMCI SPI Interface software, Windows 2000/XP supported

Interface Cable – AMCI CSMD-5 5 ft serial cable (optional)

Notes:

- Maximum temperature of the SD7540A drive mounting plate must not exceed 85°C (185°F). If these temperatures are exceeded the SD thermal protection circuit will shut down the drive.
- Operating motor current - configure the minimum current needed to provide the torque for your specific application. This will decrease the operating temperature of the SD7540 and its attached motor
- Idle current: This is the amount of current that the drive provides to the motor when motion is not occurring. To maximize drive efficiency and motor cooling, set the idle current to the minimum value necessary to provide the required holding torque.
- Supply voltage: In general, the higher supply voltage leads to higher switching losses and higher heat generation in the motor-drive system.
- The SD7540A is designed to be mounted on a metal panel that will help dissipate heat. Any metal surface larger than the SD7540A mounting plate, such as an enclosure wall, is acceptable.

SD7540A Torque Curves

SM2340-130

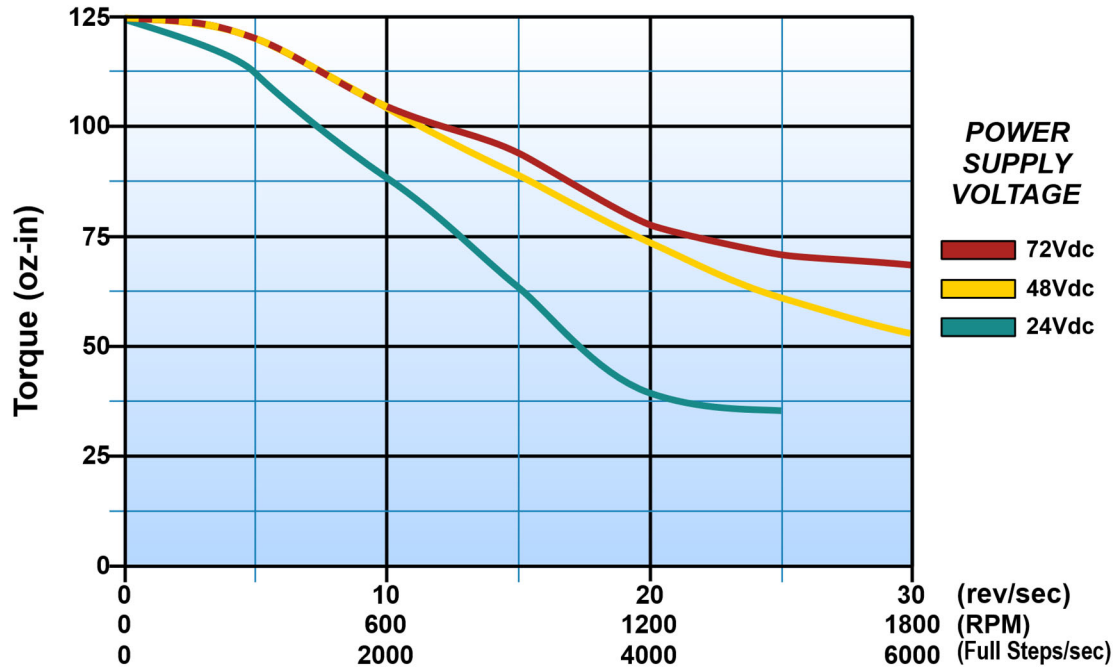

SM2340-240

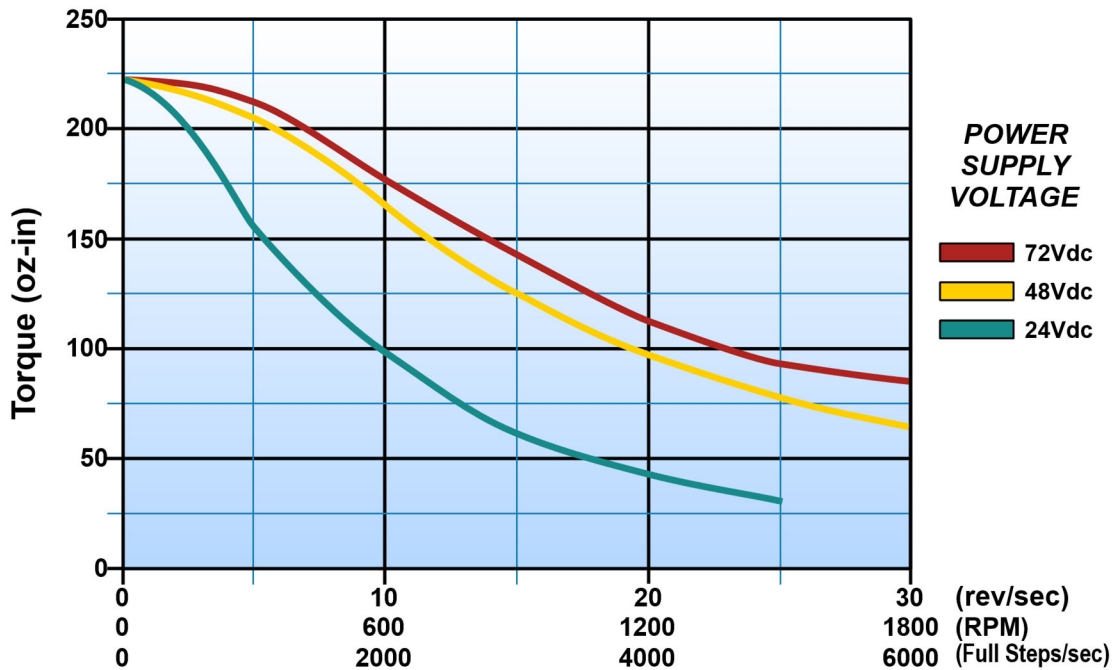

SD7540A Torque Curves

SM34-450

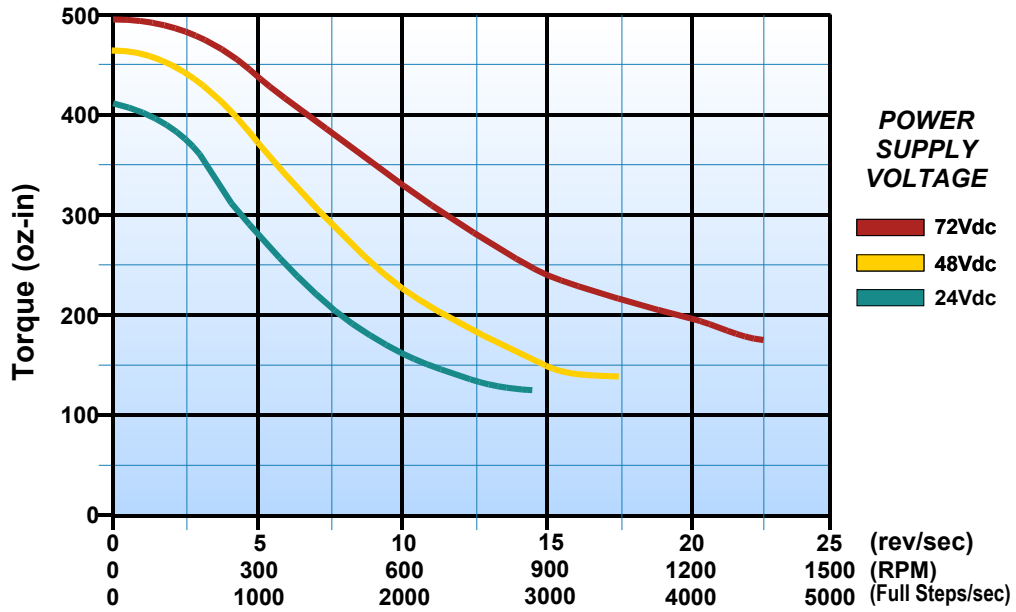

SM34-850

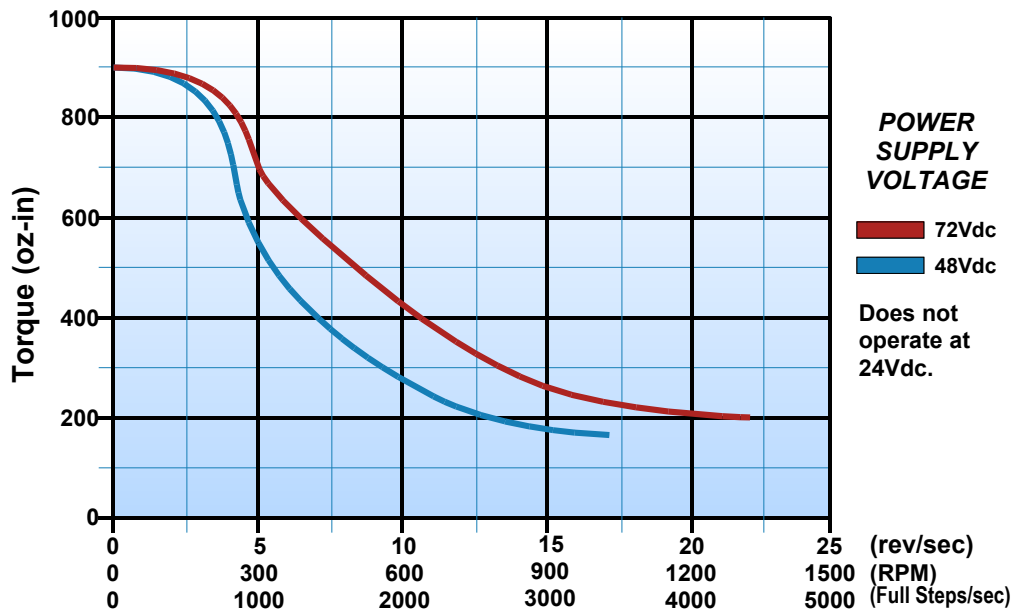

SD7540A Torque Curves

SM34-1100

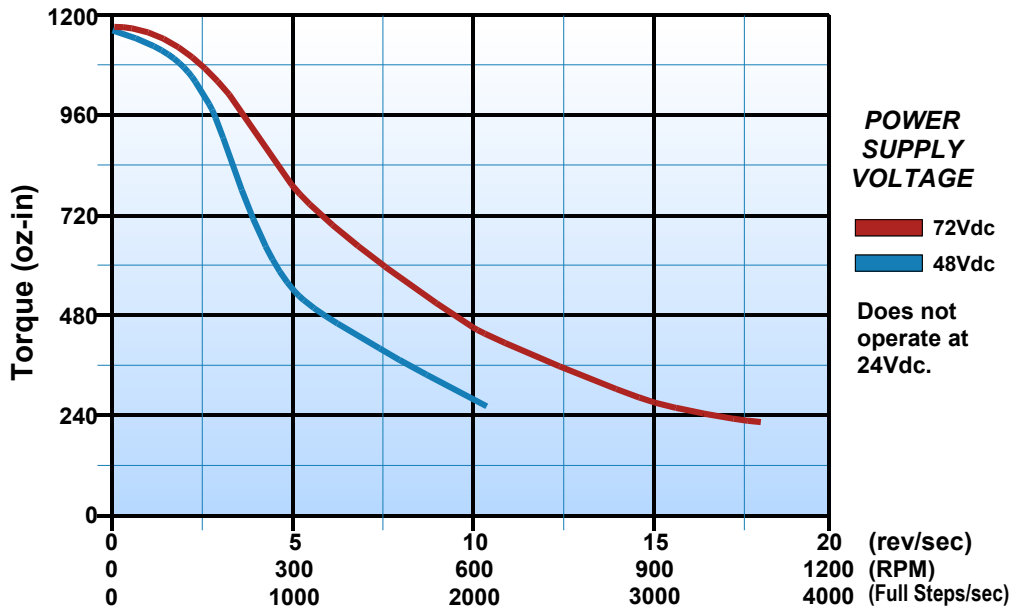

NOTE: Current setting for each torque curve was measured at 4.0 Arms.

SD7540A Outline Drawing

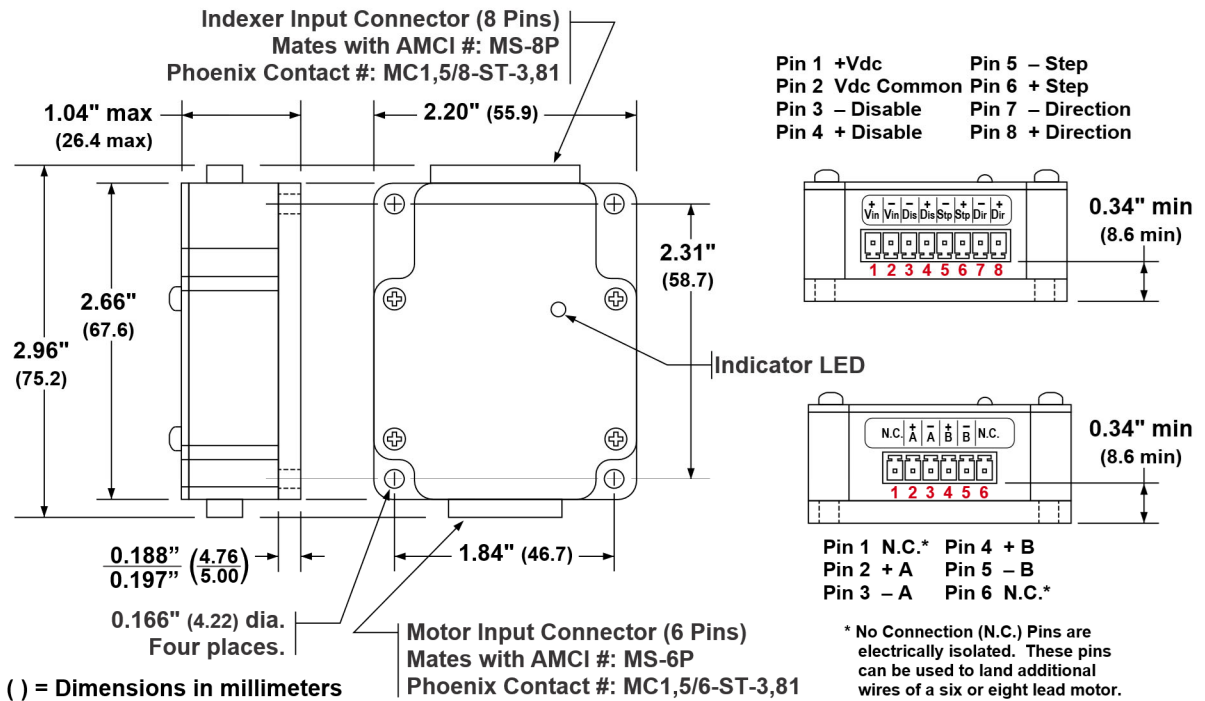

The Indicator LED is on when power is applied to the drive and there is no motion. When the SD7540A is accepting a pulse train input, the LED blinks at the same frequency as the pulses being applied to the STEP input.

SD7540A Electrical Installation



Power supply inputs are NOT reverse connection protected. Applying reverse voltage will damage unit.

Logic inputs are rated for 5Vdc max. Exceeding 5vdc will damage the unit unless the recommended limiting resistors are used.

Control Signal Wiring

Pin 1 +Vdc	Pin 5 – Step
Pin 2 Vdc Common	Pin 6 + Step
Pin 3 – Disable	Pin 7 – Direction
Pin 4 + Disable	Pin 8 + Direction

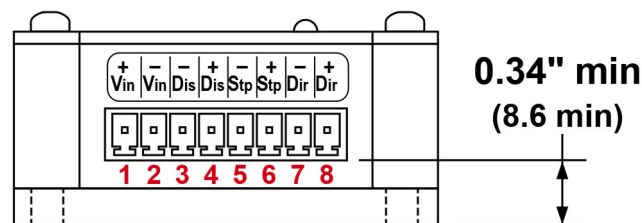

Motor Wiring

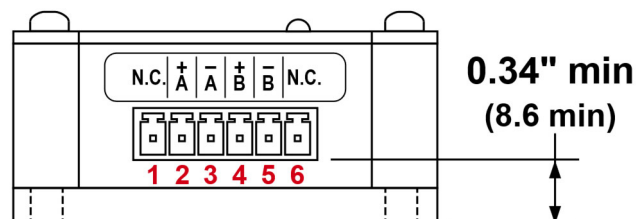

Pin 1 N.C.*	Pin 4 + B
Pin 2 + A	Pin 5 – B
Pin 3 – A	Pin 6 N.C.*

* No Connection (N.C.) Pins are electrically isolated. These pins can be used to land additional wires of a six or eight lead motor.

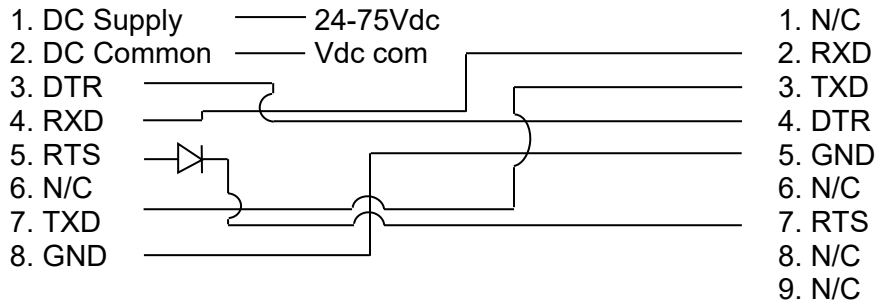

The motor pin out applies to units with a serial number D02070100 and above. Prior to this serial number, the motor connections were in a reversed order.

Programmer Wiring – CSMD-5 cableSD7540A Connector – AMCI part # MS-8PSerial Port Connector – DB-9To SMDTo PC Serial Port

Use a general purpose diode with a breakdown voltage greater than 30Vdc such as 1N4005 or 1N4148 to protect the SD RTS input.

The eight pin connector of the SD7540A is used for programming and control. The SD7540A drive monitors the TXD signal coming from the computer's serial port for a specific sequence of data. When the SD7540A receives this data, it enters programming mode. To exit programming mode you must cycle power on the SD7540A and reconnect the motion control signals. The SD7540A automatically enters motion mode when power is re-applied.

Wiring the SD7540A Control Signals to a Single-Ended Input

The SD7540A is built with differential inputs for optimal noise immunity. However, many stepper control circuits use single-ended (sinking or sourcing) control signals. The following schematics show the correct wiring when using the SD7540A with single-ended control signals.

Open Collector Sourcing Output

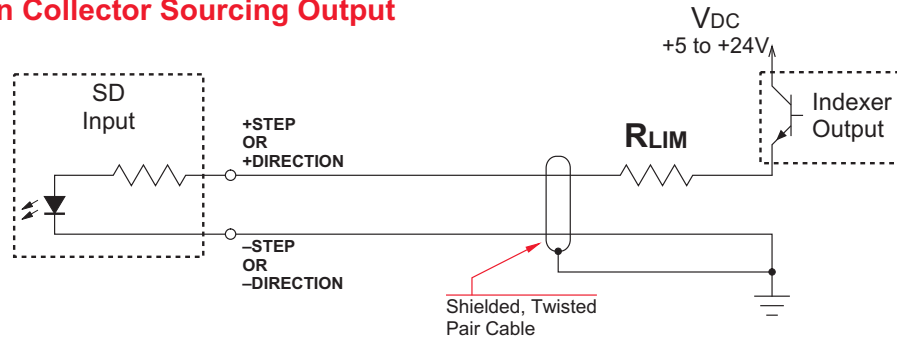

V _{DC}	R _{LIMIT}
5 Volts	None
12 Volts	2.0 K Ω
15 Volts	2.0 K Ω
24 Volts	3.9 K Ω

Open Collector Sinking Output

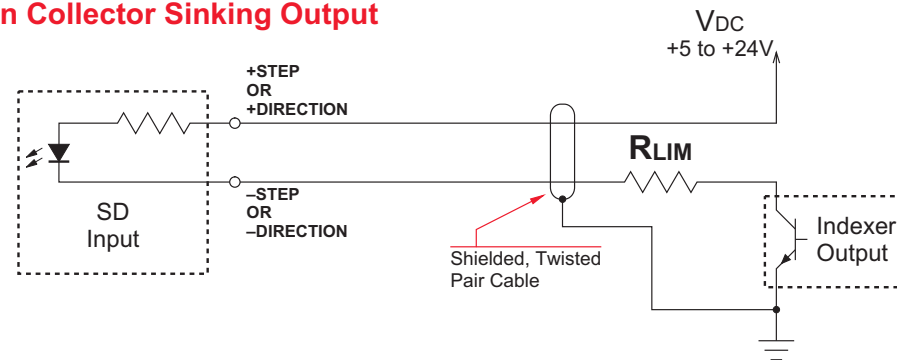

Note: For the Disable input, the internal resistor is 1 k Ω . For the Step and Direction inputs, the internal resistor is 316 Ω

Disable Input Wiring

The Disable Input on the SD7540A will shut off motor current when active. With the exception of the internal resistor value, the circuitry of the Disable Input is identical to the Step and Direction Inputs.

The SD7540A does not accept directional pulses while the Disable Input is active.

If not used, the Disable Input pins can be left open. The SD7540A will never disable the motor current if these pins are left open.

CHANGING THE SD7540A CONFIGURATION SETTINGS

Equipment required for changing the drive settings:

- Power supply – 24 to 75VDC, 4 Amps;
- Programming cable - AMCI CSMD-5, 5 ft serial cable(optional). It connects the drive to a PC. The connections are described in the document. The drive circuit provides optical isolation from the PC;
- PC running Windows 98/2000/XP;
- AMCI SPI Programming software, downloadable from the AMCI website (www.amci.com);

Procedure:

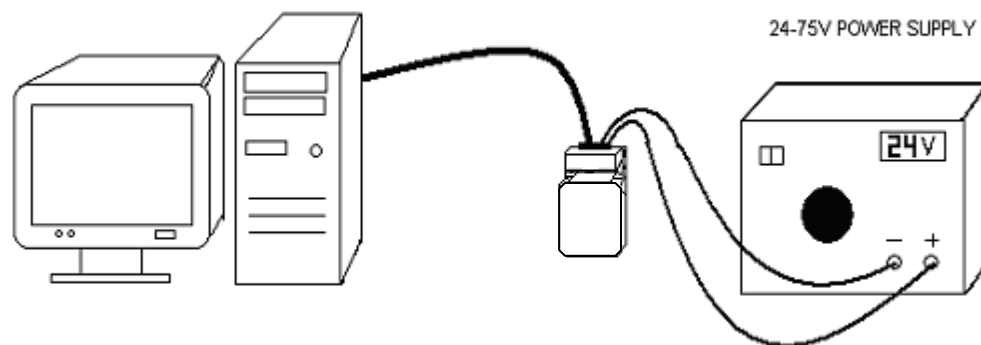

1. Install the AMCI SPI Programming software on the PC.
2. Connect the programming cable (AMCI part# CSMD-5, optional) to the SD7540A.
3. Connect the power supply to the same connector (follow the specified polarity).
4. Connect the D-Sub connector of the programming cable to the serial port of the PC.
5. Run the AMCI SPI programming software. The following window will appear on the screen:

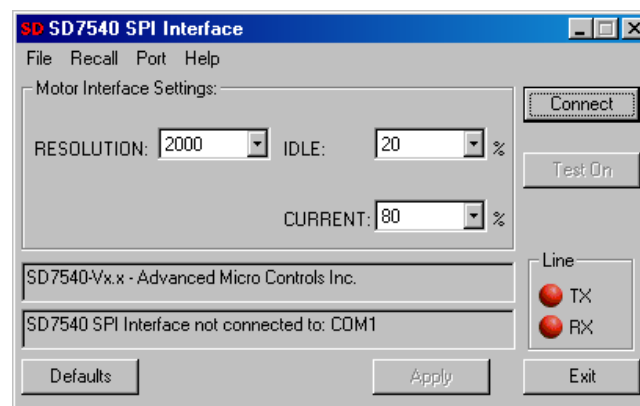

6. Select the **Port** menu and choose the COM port that the cable is connected to:

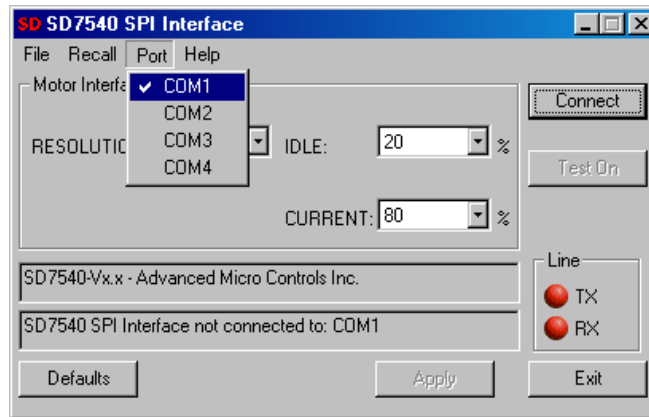

7. Turn on the power supply to the drive. The LED indicator should light.
8. Press the **Connect** button. For a few seconds the TX and the RX lights can change their color to green to inform that the program is establishing the communication. Once they settle to red, the communication is established. The current settings of the drive will be displayed (RESOLUTION, IDLE and CURRENT), together with the identification string of the drive. The motor will be disabled until the next power up.

For example:

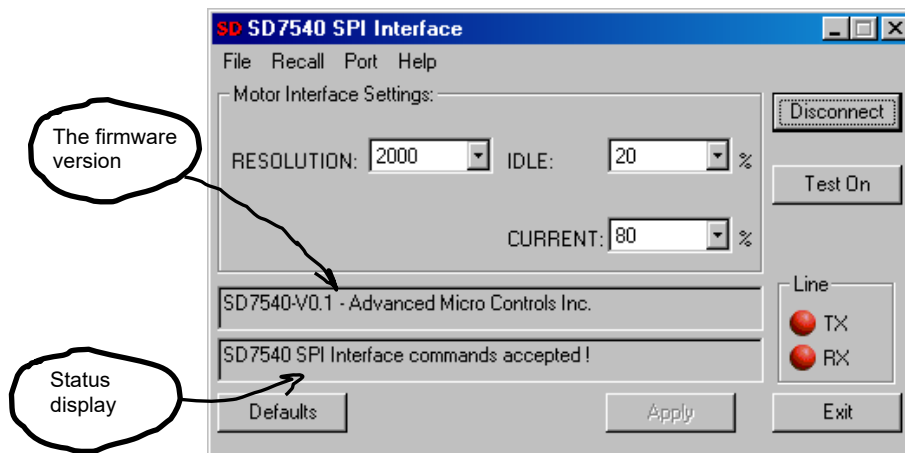

9. If a change to a setting is required, the new setting is selected from the appropriate field. By pressing the **Defaults** button, the default settings will appear:
- RESOLUTION 2000 steps/revolution;
 - IDLE 20 %;
 - CURRENT 80 %;
10. By pressing the **Apply** button, the new settings will be saved in the drive's nonvolatile memory. The process of saving and verifying the new settings will take about 8 seconds. During this time a warning to wait is displayed in the status display of the window. When the process ends, a message that the command is accepted is displayed.
11. Pressing the **Test On** button starts the self-test. The motor will move back and forth quarter of a revolution with slow speed until the **Test** button is pressed again. The LED of the SD7540A will blink indicating the application of drive steps.

Pressing the **Recall** button (in the menu above) will display the SD7540A's current settings in the data windows.

ERROR MESSAGES:

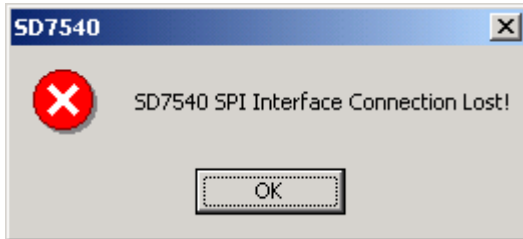

- Check if power is applied to the motor;
- Check the wire connection;
- Check if the correct COM port is selected;



ADVANCED MICRO CONTROLS INC.

20 GEAR DRIVE, TERRYVILLE, CT 06786 T: (860) 585-1254 F: (860) 584-1973

www.amci.com



Waste Electrical and Electronic Equipment (WEEE)

At the end of life, this equipment should be collected separately from any unsorted municipal waste.